

Mathematics
Additional Question Bank
Higher

6597

Update Spring 2000

HIGHER STILL

Mathematics

Additional Question Bank

Higher

Support Materials



Dear Colleague

Mathematics – Additional Question Bank – Higher (Ref No 4972)

I have pleasure in enclosing the following additional material and replacement pages which should be added to the above support pack. **[Please note that each section is numbered separately]**

This pack contains the following:

- A replacement title page for the Additional Question Bank
- A new Contents page for the revised pack. This shows how the revised pack should be assembled.
- A new section 3 which contains the short response question analysis grids. (Pages 1-11)
- A new section 4 which contains the short response questions from past Higher Mathematics question papers from 1989 to 1999 inclusive. (Pages 1-114)
- A new section 5 which contains the extended response question analysis grids. (Pages 1-11). These grids are set out in a different order to those in the existing pack. This insertion is in chronological order to make it easier to add further questions to the bank.
- A replacement page 59/60 and additional pages of extended response questions. (Pages 113-123).

All of the above should be separated and inserted in various parts of the “Mathematics – Additional Question Bank – Higher” folder issued in Spring 1999. In order to make the insertions correctly please follow these instructions.

1. Replace the original front page with the new Spring 2000 version.
2. Insert the new contents page after the front page and before the “Introduction” section.
3. Replace the original “Short response question analysis “ grids (Pages 1-12) with the new section. (Pages 1-11).
4. Insert the “Short response questions” (Pages 1-114) after the “Short response question” grids and before the “Extended. response question” grids.
5. Replace the original “Extended response question analysis” grids (Pages 1-8) with the new section (Pages 1-11).
6. Within the “Extended response questions” section, replace page 59/60 with the new version and add on the additional pages 113 to 123 at the end.

I hope that you find this extended pack helpful in your Higher Mathematics assessment procedures.

Yours faithfully



Steve Kelly
Field Officer

CONTENTS

Section 1: INTRODUCTION

Section 2: CONTENT REFERENCE LIST

Section 3: SHORT RESPONSE QUESTION ANALYSIS

Section 4: SHORT RESPONSE QUESTIONS

Section 5: EXTENDED RESPONSE QUESTION ANALYSIS

Section 6: EXTENDED RESPONSE QUESTIONS

(New) Section 3

SHORT RESPONSE QUESTION ANALYSIS

Pages 1-11

Main Unit & Outcome	part	marks	Unit	marks distribution						Content Main	Reference Additional	E.R.Q. page no.	Source
				non calc		calc		calc neut					
				C	A/B	C	A/B	C	A/B				
1.1		3					3		1.1.7	1.1.9	93	SQA : H : PI 1989 Qu. 1	
2.1		4		4					2.1.3		93	SQA : H : PI 1989 Qu. 2	
3.1	(a)	1					1		3.1.8		94	SQA : H : PI 1989 Qu. 3	
	(b)	2					2		3.1.1				
3.1		3					3		3.1.4		94	SQA : H : PI 1989 Qu. 4	
2.2		3		3					2.2.4		95	SQA : H : PI 1989 Qu. 5	
3.1		3					3		3.1.10		95	SQA : H : PI 1989 Qu. 6	
2.3		4		4					2.3.1	1.2.11	96	SQA : H : PI 1989 Qu. 7	
1.2		4		4					1.2.8	1.2.9	96	SQA : H : PI 1989 Qu. 8	
3.1		5		1	4				3.1.9		97	SQA : H : PI 1989 Qu. 9	
3.2		4		2	2				3.2.2	1.3.1	97	SQA : H : PI 1989 Qu. 10	
2.3		4			4				2.3.2		98	SQA : H : PI 1989 Qu. 11	
1.3		3		1	2				1.3.4	0.1	98	SQA : H : PI 1989 Qu. 12	
1.3		4		4					1.3.9	1.1.3	99	SQA : H : PI 1989 Qu. 13	
1.3	(a)	2					2		1.3.9		99	SQA : H : PI 1989 Qu. 14	
	(b)	2					2		1.2.4				
2.3		4		4					2.3.1		100	SQA : H : PI 1989 Qu. 15	
2.2		5		4	1				2.2.5		100	SQA : H : PI 1989 Qu. 16	
1.2		3			3				1.2.5		101	SQA : H : PI 1989 Qu. 17	
2.4		5					2	3	2.4.4		101	SQA : H : PI 1989 Qu. 18	
1.2		4					2	2	1.2.6	1.2.1	102	SQA : H : PI 1989 Qu. 19	
3.3	(a)	1					1		3.3.4		102	SQA : H : PI 1989 Qu. 20	
	(b)	4					1	3	3.3.7				
3.3		3					1	2	3.3.4		103	SQA : H : PI 1989 Qu. 21	

Main Unit & Outcome	part	marks	Unit	marks distribution						Content Main	Reference Additional	E.R.Q. page no.	Source
				non calc		calc		calc neut					
				C	A/B	C	A/B	C	A/B				
2.1		3					3		2.1.1		83	SQA : H : PI 1990 Qu. 1	
1.3		4		4					1.3.9	1.1.7	83	SQA : H : PI 1990 Qu. 2	
1.1		4					4		1.1.9	1.1.7	84	SQA : H : PI 1990 Qu. 3	
3.1		4					4		3.1.7	3.1.6	84	SQA : H : PI 1990 Qu. 4	
3.1	(a)	1					1		3.1.1		85	SQA : H : PI 1990 Qu. 5	
	(b)	1					1		3.1.3				
2.2		5		5					2.2.5	2.2.6	85	SQA : H : PI 1990 Qu. 6	
2.4		5					5		2.4.2	2.4.3	86	SQA : H : PI 1990 Qu. 7	
2.2		3		3					2.2.8		86	SQA : H : PI 1990 Qu. 8	
2.3		4		4					2.3.3		87	SQA : H : PI 1990 Qu. 9	
2.3	(b)	3			3				2.3.1		87	SQA : H : PI 1990 Qu. 10	
	(a)	2			2				1.2.2	1.2.7			
1.2		3		2	1				1.2.4		88	SQA : H : PI 1990 Qu. 11	
3.1		3					3		3.1.8		88	SQA : H : PI 1990 Qu. 12	
2.2	(b)	3		3					2.2.7		89	SQA : H : PI 1990 Qu. 13	
	(a)	2		2					0.1				
3.3		6					2	4	3.3.6	1.1.7	89	SQA : H : PI 1990 Qu. 14	
2.3		3		3					2.3.1	1.2.11	90	SQA : H : PI 1990 Qu. 15	
1.3		5		2	3				1.3.11		90	SQA : H : PI 1990 Qu. 16	
1.2		3			3				1.2.4	1.2.5	91	SQA : H : PI 1990 Qu. 17	
2.1		4					1	3	2.1.6		91	SQA : H : PI 1990 Qu. 18	
3.2		4		2	2				3.2.2	1.3.4	92	SQA : H : PI 1990 Qu. 19	
1.1		5			1	4			1.1.10	1.1.3	92	SQA : H : PI 1990 Qu. 20	

Main Unit & Outcome	part	marks	Unit	marks distribution						Content Main	Reference Additional	E.R.Q. page no.	Source
				non calc		calc		calc neut					
				C	A/B	C	A/B	C	A/B				
1.1		2					2		1.1.7	1.1.8	73	SQA : H : PI 1991 Qu. 1	
1.1		2		2					1.1.1	1	73	SQA : H : PI 1991 Qu. 2	
3.1		3					3		3.1.8	3.1.10	74	SQA : H : PI 1991 Qu. 3	
3.3	(a)	1			1				3.3.4		74	SQA : H : PI 1991 Qu. 4	
	(b)	2			2				3.3.4				
1.3		4		4					1.3.9	1.1.7	75	SQA : H : PI 1991 Qu. 5	
2.1		5					5		2.1.1		75	SQA : H : PI 1991 Qu. 6	
3.1	(a)	4					4		3.1.7		76	SQA : H : PI 1991 Qu. 7	
	(b)	1					1		3.1.6				
2.4		5					5		2.4.4		76	SQA : H : PI 1991 Qu. 8	
1.2	(a)	2		2					1.2.4		77	SQA : H : PI 1991 Qu. 9	
	(b)	3		3					1.2.4				
2.2		5		5					2.2.8		77	SQA : H : PI 1991 Qu. 10	
1.4		4			4				1.4.3		78	SQA : H : PI 1991 Qu. 11	
2.3		3		3					2.3.3		78	SQA : H : PI 1991 Qu. 12	
3.2		4			4				3.2.2		79	SQA : H : PI 1991 Qu. 13	
1.2	(a)	1					1		1.2.1		79	SQA : H : PI 1991 Qu. 14	
	(b)	2					2		1.2.1				
1.2	(a)	2			2				1.2.8		80	SQA : H : PI 1991 Qu. 15	
	(b)	2			2				1.2.9				
2.2	(a)	3		3					2.2.5		80	SQA : H : PI 1991 Qu. 16	
	(b)	2		2					2.2.6				
3.1		5					5		3.1.9	3.1.10	81	SQA : H : PI 1991 Qu. 17	
2.1		5		1	4				2.1.6		81	SQA : H : PI 1991 Qu. 18	
1.2	(a)	2		2					1.2.6		82	SQA : H : PI 1991 Qu. 19	
	(b)	2			2				1.2.6				
2.3		4		1	3				2.3.5		82	SQA : H : PI 1991 Qu. 20	

Main Unit & Outcome	part	marks	Unit	marks distribution						Content Main	Reference Additional	E.R.Q. page no.	Source
				non calc		calc		calc neut					
				C	A/B	C	A/B	C	A/B				
1.3		4		4					1.3.9	1.1.7	63	SQA:H:PI 1992 Qu. 1	
1.1	(a)	6		6					1.1.7	1.1.9 1.1.10	63	SQA:H:PI 1992 Qu. 2	
	(b)	2		2					1.1.10				
2.1		3					3		2.1.1		64	SQA:H:PI 1992 Qu. 3	
2.2		4		4					2.2.8		64	SQA:H:PI 1992 Qu. 4	
2.3		5			5				2.3.1		65	SQA:H:PI 1992 Qu. 5	
1.2		3		3					1.2.6		65	SQA:H:PI 1992 Qu. 6	
3.4	(a)	4			4				3.4.1		66	SQA:H:PI 1992 Qu. 7	
	(b)	2			1	1			3.4.3				
2.2		5		5					2.2.5		66	SQA:H:PI 1992 Qu. 8	
2.4		5					5		2.4.2	1.1.2 0.1	67	SQA:H:PI 1992 Qu. 9	
1.2	(a)	2					2		1.2.4		67	SQA:H:PI 1992 Qu. 10	
	(b)	2					2		1.2.4				
3.2		4		1	3				3.2.2		68	SQA:H:PI 1992 Qu. 11	
1.2		2						2	1.2.3		68	SQA:H:PI 1992 Qu. 12	
1.1		3			3				1.1.3		69	SQA:H:PI 1992 Qu. 13	
3.2	(a)	3			3				3.2.4		69	SQA:H:PI 1992 Qu. 14	
	(b)	2		1	1				1.2.3	2.2.6			
3.1		3					3		3.1.6		70	SQA:H:PI 1992 Qu. 15	
2.4		5					5		2.4.1	1.1.2 0.1	70	SQA:H:PI 1992 Qu. 16	
2.1		4		1	3				2.1.7		71	SQA:H:PI 1992 Qu. 17	
3.1		3					3		3.1.9		71	SQA:H:PI 1992 Qu. 18	
1.3		4					1	3	1.3.7	1.2.4	72	SQA:H:PI 1992 Qu. 19	

Main Unit & Outcome	part	marks	Unit	marks distribution						Content Main	Reference Additional	E.R.Q. page no.	Source
				non calc		calc		calc neut					
				C	A/B	C	A/B	C	A/B				
3.1	(a)	1					1		3.1.1		52	SQA : H : PI 1993 Qu. 1	
	(b)	2					2		3.1.3				
1.1	(a)	3					3		1.1.7	1.1.9	52	SQA : H : PI 1993 Qu. 2	
	(b)	1					1		1.2.9				
2.1		2	2						2.1.7		53	SQA : H : PI 1993 Qu. 3	
1.3		4	4						1.3.10		53	SQA : H : PI 1993 Qu. 4	
2.4	(a)	3					3		2.4.1		54	SQA : H : PI 1993 Qu. 5	
	(b)	1					1		2.4.3				
2.3		3	3						2.3.2		54	SQA : H : PI 1993 Qu. 6	
2.1		4	4						2.1.2		55	SQA : H : PI 1993 Qu. 7	
1.2		3	1	2					1.2.4		55	SQA : H : PI 1993 Qu. 8	
3.2		4	2	2					3.2.2	1.3.4	56	SQA : H : PI 1993 Qu. 9	
1.1	(a)	4			4				1.1.3		56	SQA : H : PI 1993 Qu. 10	
	(b)	1			1				0.1				
2.2		4	4						2.2.4	1.2.9	57	SQA : H : PI 1993 Qu. 11	
3.1	(a)	3					3		3.1.8	3.1.9	57	SQA : H : PI 1993 Qu. 12	
	(b)	2					2		3.1.10				
1.2	(a)	2	2						1.2.6		58	SQA : H : PI 1993 Qu. 13	
	(b)	2	2						1.2.6				
	(c)	1		1					0.1				
1.2		3	3					1.2.4	1.2.1	58	SQA : H : PI 1993 Qu. 14		
3.3	(a)	4			1	3			3.3.5		59	SQA : H : PI 1993 Qu. 15	
	(b)	1			1				1.2.7				
3.2		4		4				3.2.3		59	SQA : H : PI 1993 Qu. 16		
2.3		4			2	2		2.3.1		60	SQA : H : PI 1993 Qu. 17		
2.4		2					2	2.4.2		60	SQA : H : PI 1993 Qu. 18		
3.2	(a)	1	1					2.3.3		61	SQA : H : PI 1993 Qu. 19		
	(b)	3		3				3.2.4					
3.3		4					1	3	3.3.5		61	SQA : H : PI 1993 Qu. 20	
1.3		4	1	3				1.3.11		62	SQA : H : PI 1993 Qu. 21		

Main Unit & Outcome	part	marks	Unit	marks distribution						Content Main	Reference Additional	E.R.Q. page no.	Source
				non calc		calc		calc neut					
				C	A/B	C	A/B	C	A/B				
2.2		3		3					2.2.4		42	SQA:H:PI 1994 Qu. 1	
1.3		3		3					1.3.4	0.1	42	SQA:H:PI 1994 Qu. 2	
3.1		3						3	3.1.4	3.1.1	43	SQA:H:PI 1994 Qu. 3	
3.1		3						3	3.1.7		43	SQA:H:PI 1994 Qu. 4	
2.4		4						4	2.4.1	1.1.9	44	SQA:H:PI 1994 Qu. 5	
2.3		3		3					2.3.2		44	SQA:H:PI 1994 Qu. 6	
3.1		3						3	3.1.2	3.1.10	45	SQA:H:PI 1994 Qu. 7	
2.4	(a)	3						3	2.4.4		45	SQA:H:PI 1994 Qu. 8	
	(b)	3						3	2.4.3				
1.4	(a)	1				1			1.4.2		46	SQA:H:PI 1994 Qu. 9	
	(b)	1				1			1.4.3				
	(c)	2				2			1.4.5				
3.2		4			4				3.2.2		46	SQA:H:PI 1994 Qu. 10	
1.2		3		3					1.2.8	1.2.9	47	SQA:H:PI 1994 Qu. 11	
1.2	(a)	3		3					1.2.3		47	SQA:H:PI 1994 Qu. 12	
	(b)	3		3					2.3.1	1.2.11			
2.3	(a)	2		2					2.3.3		48	SQA:H:PI 1994 Qu. 13	
	(b)	3				3			2.3.3				
1.3		6		6					1.3.9	1.1.3	48	SQA:H:PI 1994 Qu. 14	
2.3		5				1	4		2.3.5		49	SQA:H:PI 1994 Qu. 15	
3.3	(a)	3		2	1				3.3.4	1.2.4	49	SQA:H:PI 1994 Qu. 16	
	(b)	2				2			3.3.2	1.2.4			
3.2		4		1	3				3.2.2	2.2.3	50	SQA:H:PI 1994 Qu. 17	
3.1		3						3	3.1.3		50	SQA:H:PI 1994 Qu. 18	
1.2		3		1	2				1.2.6		51	SQA:H:PI 1994 Qu. 19	
3.3		4					4		3.3.4		51	SQA:H:PI 1994 Qu. 20	

Main Unit & Outcome	part	marks	Unit	marks distribution						Content Main	Reference Additional	E.R.Q. page no.	Source
				non calc		calc		calc neut					
				C	A/B	C	A/B	C	A/B				
3.1		2					2		3.1.8		31	SQA : H : PI 1995 Qu. 1	
2.1	(a)	2		2					2.1.3		31	SQA : H : PI 1995 Qu. 2	
	(b)	2		2					2.1.3				
3.2		4		4					3.2.4		32	SQA : H : PI 1995 Qu. 3	
3.1		3					3		3.1.10		32	SQA : H : PI 1995 Qu. 4	
1.1		3					3		1.1.7	1.1.11	33	SQA : H : PI 1995 Qu. 5	
1.1		5					5		1.1.10		33	SQA : H : PI 1995 Qu. 6	
1.3		4		4					1.3.4		34	SQA : H : PI 1995 Qu. 7	
2.3		4		4					2.3.1	1.2.11	34	SQA : H : PI 1995 Qu. 8	
2.4		3					3		2.4.3		35	SQA : H : PI 1995 Qu. 9	
1.3	(b)	3		3					1.3.11		35	SQA : H : PI 1995 Qu. 10	
	(a)	1		1					0.1				
1.2	(a)	3		2	1				1.2.6		36	SQA : H : PI 1995 Qu. 11	
	(b)	1			1				1.2.1				
2.3		3		3					2.3.3		36	SQA : H : PI 1995 Qu. 12	
3.4		4				4			3.4.1		37	SQA : H : PI 1995 Qu. 13	
1.3		2		2					1.3.7		37	SQA : H : PI 1995 Qu. 14	
2.3		5					5		2.3.5		38	SQA : H : PI 1995 Qu. 15	
3.1		4					1	3	3.1.9		38	SQA : H : PI 1995 Qu. 16	
1.2	(a)	3					2	1	1.2.4		39	SQA : H : PI 1995 Qu. 17	
	(b)	1						1	1.2.4				
3.3	(a)	3				1	2		3.3.7		39	SQA : H : PI 1995 Qu. 18	
	(b)	2					2		3.3.7				
3.3		3						3	3.3.4		40	SQA : H : PI 1995 Qu. 19	
2.1		5					1	4	2.1.7		40	SQA : H : PI 1995 Qu. 20	
1.3	(a)	3		1	2				1.3.6		41	SQA : H : PI 1995 Qu. 21	
	(b)	2					2		1.2.9				

Main Unit & Outcome	part	marks	Unit	marks distribution						Content Main	Reference Additional	E.R.Q. page no.	Source
				non calc		calc		calc neut					
				C	A/B	C	A/B	C	A/B				
1.1		4					4		1.1.1	1.1.9	21	SQA:H:PI 1996 Qu. 1	
2.1		2		2					2.1.7		21	SQA:H:PI 1996 Qu. 2	
1.2		3		3					1.2.9		22	SQA:H:PI 1996 Qu. 3	
1.1		4					4		1.1.1	1.1.9 2.4.2	22	SQA:H:PI 1996 Qu. 4	
2.2		4		4					2.2.4	2.2.5	23	SQA:H:PI 1996 Qu. 5	
3.1		4					4		3.1.7	3.1.6	23	SQA:H:PI 1996 Qu. 6	
2.1		4		4					2.1.3		24	SQA:H:PI 1996 Qu. 7	
1.2	(i)	2					2		1.2.4		24	SQA:H:PI 1996 Qu. 8	
	(ii)	3					3		1.2.4				
1.3		5		5					1.3.4		25	SQA:H:PI 1996 Qu. 9	
2.3		5		5					2.3.5		25	SQA:H:PI 1996 Qu. 10	
1.4	(a)	1					1		1.4.4		26	SQA:H:PI 1996 Qu. 11	
	(b)	2					2		1.4.5				
2.3		4		4					2.3.1	1.2.11	26	SQA:H:PI 1996 Qu. 12	
3.2		3			3				3.2.2	3.2.1	27	SQA:H:PI 1996 Qu. 13	
0.1		4		4					0.1		27	SQA:H:PI 1996 Qu. 14	
2.3		3					3		2.3.2		28	SQA:H:PI 1996 Qu. 15	
1.3		4		2	2				1.3.11	2.1.9	28	SQA:H:PI 1996 Qu. 16	
1.2		3		3					1.2.8		29	SQA:H:PI 1996 Qu. 17	
2.3		5		1	4				2.3.4		29	SQA:H:PI 1996 Qu. 18	
3.3		5				1	4		3.3.7		30	SQA:H:PI 1996 Qu. 19	
2.4		6					1	5	2.4.3	0.1	30	SQA:H:PI 1996 Qu. 20	

Main Unit & Outcome	part	marks	Unit	marks distribution						Content Main	Reference Additional	E.R.Q. page no.	Source
				non calc		calc		calc neut					
				C	A/B	C	A/B	C	A/B				
1.1		3					3		1.1.1	1.1.9 1.1.7	11	SQA : H : PI 1997 Qu. 1	
3.1		3					3		3.1.7		11	SQA : H : PI 1997 Qu. 2	
1.2		4		4					1.2.6		12	SQA : H : PI 1997 Qu. 3	
3.1	(a)	2					2		3.1.8	3.1.1	12	SQA : H : PI 1997 Qu. 4	
	(b)	1					1		3.1.3				
2.1	(a)	2		2					2.1.2		13	SQA : H : PI 1997 Qu. 5	
	(b)	3		3					2.1.7				
1.1		5		5					1.1.8	1.3.7 1.3.10	13	SQA : H : PI 1997 Qu. 6	
2.3		3		3					2.3.2		14	SQA : H : PI 1997 Qu. 7	
1.3		3		3					1.3.4		14	SQA : H : PI 1997 Qu. 8	
1.2	(a)	3		3					1.2.8		15	SQA : H : PI 1997 Qu. 9	
	(b)	1		1					1.2.9				
2.2		4		4					2.2.5		15	SQA : H : PI 1997 Qu. 10	
3.4		4			4				3.4.1		16	SQA : H : PI 1997 Qu. 11	
2.4		5					5		2.4.2	3.1.6	16	SQA : H : PI 1997 Qu. 12	
3.1		4					1	3	3.1.9	3.1.10	17	SQA : H : PI 1997 Qu. 13	
2.4		3					2	1	2.4.2		17	SQA : H : PI 1997 Qu. 14	
3.2		3			3				3.2.4		18	SQA : H : PI 1997 Qu. 15	
1.2	(a)	2		2					1.2.4		18	SQA : H : PI 1997 Qu. 16	
	(b)	2		2					1.2.4				
	(c)	1			1				0.1				
3.3		4						4	3.3.4		19	SQA : H : PI 1997 Qu. 17	
2.3	(a)	2			1	1			2.3.3		19	SQA : H : PI 1997 Qu. 18	
	(b)	4			1	3			2.3.5				
3.3	(a)	2					2		3.3.4		20	SQA : H : PI 1997 Qu. 19	
	(b)	2						2	1.2.4				
	(c)	1					1		0.1				
1.3		4			1	3			1.3.7	1.3.9 1.1.3	20	SQA : H : PI 1997 Qu. 20	

Main Unit & Outcome	part	marks	Unit	marks distribution						Content Main	Reference Additional	E.R.Q. page no.	Source
				non calc		calc		calc neut					
				C	A/B	C	A/B	C	A/B				
1.1		3					3		1.1.6	1.1.7	1	SQA : H : PI 1998 Qu. 1	
2.1		4		4					2.1.3		1	SQA : H : PI 1998 Qu. 2	
3.1	(a)	2					2		3.1.1		2	SQA : H : PI 1998 Qu. 3	
	(b)	1					1		3.1.9				
	(c)	1					1		3.1.1				
2.4		4					4		2.4.4		2	SQA : H : PI 1998 Qu. 4	
3.1	(a)	2					2		3.1.1		3	SQA : H : PI 1998 Qu. 5	
	(b)	2					2		3.1.1				
1.2	(a)	2					2		1.2.6		3	SQA : H : PI 1998 Qu. 6	
	(b)	2					1	1	0.1				
2.3	(a)	2		2					2.3.3		4	SQA : H : PI 1998 Qu. 7	
	(b)	1		1					2.3.3				
	(c)	2		2					2.3.2				
1.4	(a)	1			1				1.4.4		4	SQA : H : PI 1998 Qu. 8	
	(b)	2			2				1.4.5				
	(c)	2				2			1.4.3				
2.3		4		4					2.3.1	1.2.11	5	SQA : H : PI 1998 Qu. 9	
2.2		3		3					2.2.8		5	SQA : H : PI 1998 Qu. 10	
1.3		4		4					1.3.4	1.3.7	6	SQA : H : PI 1998 Qu. 11	
2.2		5		5					2.2.4		6	SQA : H : PI 1998 Qu. 12	
1.2	(a)	3					3		1.2.4		7	SQA : H : PI 1998 Qu. 13	
	(b)	2						2	1.2.4				
	(c)	1						1	1.3.8				
1.3		4		4					1.3.4		7	SQA : H : PI 1998 Qu. 14	
2.2	(b)	4		1	3				2.2.6	3.2.1	8	SQA : H : PI 1998 Qu. 15	
	(a)	1		1					1.2.3				
3.2		3			3				3.2.1	3.2.2	8	SQA : H : PI 1998 Qu. 16	
1.3	(a)	3					1	2	1.3.5	1.3.6	9	SQA : H : PI 1998 Qu. 17	
	(b)	2						2	1.3.5	1.3.6			
2.3	(a)	2					1	2	2.3.3	2.1.6	9	SQA : H : PI 1998 Qu. 18	
	(b)	1						1	1.2.1				
3.3		4		1	3				3.3.3	3.3.1 3.3.4	10	SQA : H : PI 1998 Qu. 19	

Main Unit & Outcome	part	marks	Unit	marks distribution						Content Main	Reference Additional	E.R.Q. page no.	Source
				non calc		calc		calc neut					
				C	A/B	C	A/B	C	A/B				
2.1	(a)	1	2.1	1					2.1.1		104	SQA : H : PI 1999 Qu. 1	
	(b)	3	2.1	3					2.1.2				
1.1	(a)	2	1.1					2	1.1.7		104	SQA : H : PI 1999 Qu. 2	
	(b)	3	1.1					3	1.1.10				
2.2	(a)	2	0.1	2					0.1		105	SQA : H : PI 1999 Qu. 3	
	(b)	1	2.2	1					2.2.6				
	(c)	2	2.2	2					2.2.5				
2.4	.	2	2.4					2	2.4.3		105	SQA : H : PI 1999 Qu. 4	
1.3	.	3	1.3	3					1.3.4		106	SQA : H : PI 1999 Qu. 5	
3.1	.	3	3.1					3	3.1.8		106	SQA : H : PI 1999 Qu. 6	
1.1	.	2	1.1					2	1.1.3		107	SQA : H : PI 1999 Qu. 7	
2.1	.	3	2.1					3	2.1.6		107	SQA : H : PI 1999 Qu. 8	
1.3	.	4	1.3	4					1.3.9	1.1.7	108	SQA : H : PI 1999 Qu. 9	
1.2	(a)	2	1.2	2					1.2.4		108	SQA : H : PI 1999 Qu. 10	
	(b)	3	1.2	1	2				1.2.4				
2.2	.	4	2.2	4					2.2.8		109	SQA : H : PI 1999 Qu. 11	
2.3	.	3	2.3	3					2.3.3		109	SQA : H : PI 1999 Qu. 12	
1.2	(a)	3	1.2	3					1.2.8		110	SQA : H : PI 1999 Qu. 13	
	(b)	2	1.2	2					1.2.9				
2.3	.	4	2.3	4					2.3.1		110	SQA : H : PI 1999 Qu. 14	
3.3	.	3	3.3					3	3.3.1	1.2.5	111	SQA : H : PI 1999 Qu. 15	
1.3	.	5	1.3	2	3				1.3.12	1.3.11	111	SQA : H : PI 1999 Qu. 16	
3.1	(a)	2	3.1					2	3.1.9		112	SQA : H : PI 1999 Qu. 17	
	(b)	4	3.1					4	3.1.9				
1.4	.	3	1.4					3	1.4.5		112	SQA : H : PI 1999 Qu. 18	
3.2	.	3	3.2	1	2				3.2.2	3.2.1	113	SQA : H : PI 1999 Qu. 19	
2.2	.	4	2.2	2	2				2.2.4		113	SQA : H : PI 1999 Qu. 20	
0.1	(a)	1	0.1					1	0.1		114	SQA : H : PI 1999 Qu. 21	
	(b)	3	0.1					3	0.1	1.3.4			

(New) Section 4

SHORT RESPONSE QUESTIONS

Pages 1-114

A triangle ABC has vertices A(4, 3), B(6, 1) and C(-2, -3) as shown in the diagram. Find the equation of AM, the median from A.

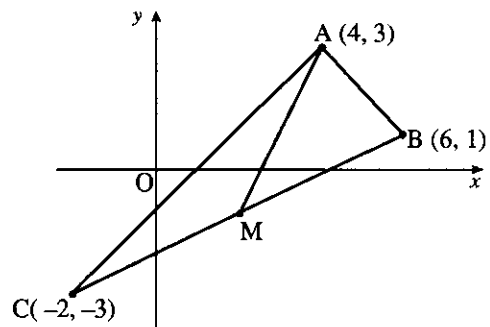

3

part marks	Unit	non-calc		calc		calc neut		Content Reference :		1.1
		C	A/B	C	A/B	C	A/B	Main	Additional	
3	1.1					3		1.1.6	1.1.7	Source 1998 P1 qu.1

- ¹ $M = (2, -1)$
- ² $m_{AM} = 2$
- ³ $y - (-1) = 2(x - 2)$

Express $x^3 - 4x^2 - 7x + 10$ in its fully factorised form.

4

part marks	Unit	non-calc		calc		calc neut		Content Reference :		2.1
		C	A/B	C	A/B	C	A/B	Main	Additional	
4	2.1	4						2.1.3		Source 1998 P1 qu.2

- ¹ evaluating $f(k)$ for any integer by any method
- ² find 1 value of k s.t. $f(k) = 0$
e.g. $f(1)$ or $f(-2)$ or $f(5)$
- ³ quad factor e.g. $x^2 - 3x - 10$
- ⁴ $(x-1)(x+2)(x-5)$

Vectors p , q and r are defined by

$$p = i + j - k, \quad q = i + 4k \quad \text{and} \quad r = 4i - 3j.$$

- (a) Express $p - q + 2r$ in component form.
 (b) Calculate $p \cdot r$
 (c) Find $|r|$.

2
1
1

part	marks	Unit	non-calc		calc		calc neut		Content Reference :		3.1
			C	A/B	C	A/B	C	A/B	Main	Additional	
(a)	2	3.1					2		3.1.1		Source 1998 P1 qu.3
(b)	1	3.1					1		3.1.9		
(c)	1	3.1					1		3.1.1		

$\bullet^1 \quad p = \begin{pmatrix} 1 \\ 1 \\ -1 \end{pmatrix}, \quad q = \begin{pmatrix} 1 \\ 0 \\ 4 \end{pmatrix}, \quad r = \begin{pmatrix} 4 \\ -3 \\ 0 \end{pmatrix} \quad s/i \text{ by } \bullet^2$	$\bullet^3 \quad 1$
$\bullet^2 \quad \begin{pmatrix} 8 \\ -5 \\ -5 \end{pmatrix}$	$\bullet^4 \quad 5$

The circle shown has equation

$$(x - 3)^2 + (y + 2)^2 = 25.$$

Find the equation of the tangent at the point $(6, 2)$.

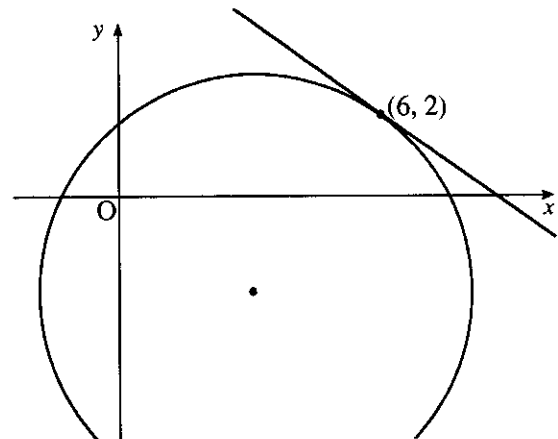

4

part	marks	Unit	non-calc		calc		calc neut		Content Reference :		2.4
			C	A/B	C	A/B	C	A/B	Main	Additional	
.	4	2.4					4		2.4.4		Source 1998 P1 qu.4

$\bullet^1 \quad \text{Centre} = (3, -2)$
$\bullet^2 \quad m_{rad} = \frac{4}{3}$
$\bullet^3 \quad m_{tgt} = -\frac{3}{4}$
$\bullet^4 \quad y - 2 = -\frac{3}{4}(x - 6)$

The line AB is divided into 3 equal parts by the points C and D, as shown. A and B have coordinates (3, -1, 2) and (9, 2, -4).

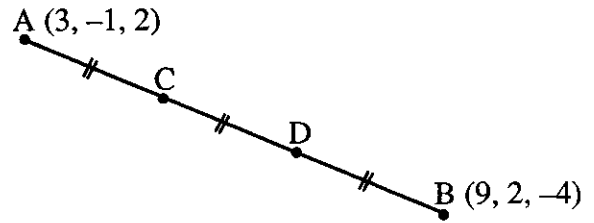

- (a) Find the components of \vec{AB} and \vec{AC} .
 (b) Find the coordinates of C and D.

2
2

part	marks	Unit	non-calc		calc		calc neut		Content Reference :		3.1
			C	A/B	C	A/B	C	A/B	Main	Additional	
(a)	2	3.1					2		3.1.1		Source
(b)	2	3.1					2		3.1.1		1998 P1 qu.5

• ¹	$\vec{AB} = \begin{pmatrix} 6 \\ 3 \\ -6 \end{pmatrix}$	• ³	$C = (5, 0, 0)$
• ²	$\vec{AC} = \begin{pmatrix} 2 \\ 1 \\ -2 \end{pmatrix}$	• ⁴	$D = (7, 1, -2)$

The functions f and g are defined on a suitable domain by $f(x) = x^2 - 1$ and $g(x) = x^2 + 2$.

- (a) Find an expression for $f(g(x))$.
 (b) Factorise $f(g(x))$.

2
2

part	marks	Unit	non-calc		calc		calc neut		Content Reference :		1.2
			C	A/B	C	A/B	C	A/B	Main	Additional	
(a)	2	1.2					2		1.2.6		Source
(b)	2	1.2					1	1	0.1		1998 P1 qu.6

• ¹	$f(x^2 + 2)$	• ³	$((x^2 + 2) + 1)((x^2 + 2) - 1)$	OR	• ³	$x^4 + 4x^2 + 3$
• ²	$(x^2 + 2)^2 - 1$	• ⁴	$(x^2 + 3)(x^2 + 1)$		• ⁴	$(x^2 + 3)(x^2 + 1)$

A and B are acute angles such that $\tan A = \frac{3}{4}$ and $\tan B = \frac{5}{12}$.

Find the exact value of

- (a) $\sin 2A$
 (b) $\cos 2A$
 (c) $\sin (2A + B)$.

2
1
2

part	marks	Unit	non-calc		calc		calc neut		Content Reference :		2.3
			C	A/B	C	A/B	C	A/B	Main	Additional	
(a)	2	2.3	2						2.3.3		Source 1998 P1 qu.7
(b)	1	2.3	1						2.3.3		
(c)	2	2.3	2						2.3.2		

• ¹ $\sin A = \frac{3}{5}$ and $\cos A = \frac{4}{5}$	• ⁴ $\sin 2A \cos B + \cos 2A \sin B$
• ² $\sin 2A = 2 \times \frac{3}{5} \times \frac{4}{5} = \frac{24}{25}$ (accept 0.96)	• ⁵ $\sin B = \frac{5}{13}$ and $\cos B = \frac{12}{13}$ and $\frac{323}{325}$
• ³ $\cos 2A =$ e.g. $\left(\frac{4}{5}\right)^2 - \left(\frac{3}{5}\right)^2 = \frac{7}{25}$ (accept 0.28)	

Two sequences are defined by these recurrence relations:

$$u_{n+1} = 3u_n - 0.4 \text{ with } u_0 = 1, \quad v_{n+1} = 0.3v_n + 4 \text{ with } v_0 = 1.$$

- (a) Explain why only one of these sequences approaches a limit as $n \rightarrow \infty$.
 (b) Find algebraically the exact value of the limit.
 (c) For the other sequence, find
 (i) the smallest value of n for which the n^{th} term exceeds 1000, and
 (ii) the value of that term.

1
2
2

part	marks	Unit	non-calc		calc		calc neut		Content Reference :		1.4
			C	A/B	C	A/B	C	A/B	Main	Additional	
(a)	1	1.4			1				1.4.4		Source 1998 P1 qu.8
(b)	2	1.4			2				1.4.5		
(c)	2	1.4				2			1.4.3		

• ¹ Only V_n has a limit because $-1 < 0.3 < 1$	• ⁴ evaluate enough terms to exceed 1000
• ² e.g. use $L = aL + b$	• ⁵ $u_7 = 1749.8$
• ³ $L = \frac{40}{7}$	

Solve the equation $2\sin\left(2x - \frac{\pi}{6}\right) = 1$, $0 \leq x < 2\pi$.

4

part marks	Unit	non-calc		calc		calc neut		Content Reference :		2.3
		C	A/B	C	A/B	C	A/B	Main	Additional	
4	2.3	4						2.3.1	1.2.1	Source 1998 P1 qu.9

<ul style="list-style-type: none"> •¹ $\sin\left(2x - \frac{\pi}{6}\right) = \frac{1}{2}$ •² $2x - \frac{\pi}{6} = \frac{\pi}{6}, \frac{5\pi}{6}$ (accept 30, 150) •³ $x = \frac{\pi}{6}, \frac{\pi}{2}$ •⁴ $x = \frac{7\pi}{6}, \frac{3\pi}{2}$ 	<p>Alternative for 2nd and 3rd marks</p> <ul style="list-style-type: none"> •² $2x - \frac{\pi}{6} = \frac{\pi}{6}, x = \frac{\pi}{6}$ •³ $2x - \frac{\pi}{6} = \frac{5\pi}{6}, x = \frac{\pi}{2}$
--	--

A curve, for which $\frac{dy}{dx} = 6x^2 - 2x$, passes through the point $(-1, 2)$.

Express y in terms of x .

3

part marks	Unit	non-calc		calc		calc neut		Content Reference :		2.2
		C	A/B	C	A/B	C	A/B	Main	Additional	
3	2.2	3						2.2.8		Source 1998 P1 qu.10

<ul style="list-style-type: none"> •¹ $y = 2x^3 - x^2$ •² $y = 2x^3 - x^2 + k$ and substituting •³ $k = 5$

The diagram shows a sketch of the curve $y = x^3 + kx^2 - 8x + 3$. The tangent to the curve at $x = -2$ is parallel to the x -axis. Find the value of k .

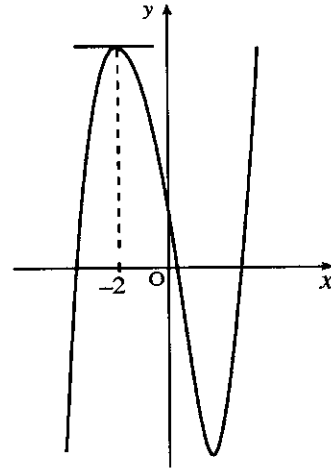

4

part marks	Unit	non-calc		calc		calc neut		Content Reference :		1.3
		C	A/B	C	A/B	C	A/B	Main	Additional	
4	1.3	4						1.3.4	1.3.7	Source 1998 P1 qu.11

<ul style="list-style-type: none"> •¹ $\frac{dy}{dx} = \dots\dots$ •² $3x^2 + 2kx - 8$ •³ $3x^2 + 2kx - 8 = 0$ when $x = -2$ •⁴ $k = 1$
--

Evaluate $\int_1^2 \left(x^2 + \frac{1}{x}\right)^2 dx$.

5

part marks	Unit	non-calc		calc		calc neut		Content Reference :		2.2
		C	A/B	C	A/B	C	A/B	Main	Additional	
5	2.2	5						2.2.4		Source 1998 P1 qu.12

<ul style="list-style-type: none"> •¹ know to expand brackets •² $x^4 + 2x + x^{-2}$ •³ $\frac{1}{5}x^5 + x^2$ •⁴ $-\frac{1}{x}$ •⁵ $9\frac{7}{10}$

A sketch of the graph of the cubic function f is shown. It passes through the origin, has a maximum turning point at $(a, 1)$ and a minimum turning point at $(b, 0)$.

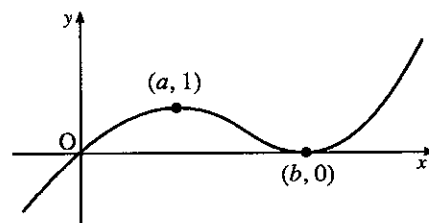

(a) Make a copy of this diagram and on it sketch the graph of $y = 2 - f(x)$, indicating the coordinates of the turning points. 3

(b) On a separate diagram sketch the graph of $y = f'(x)$. 2

(c) The tangent to $y = f(x)$ at the origin has equation $y = \frac{1}{2}x$.
Use this information to write down the coordinates of a point on the graph of $y = f'(x)$. 1

part	marks	Unit	non-calc		calc		calc neut		Content Reference :		1.2
			C	A/B	C	A/B	C	A/B	Main	Additional	
(a)	3	1.2					3		1.2.4		Source 1998 P1 qu.13
(b)	2	1.2						2	1.2.4		
(c)	1	1.2						1	1.3.8		

<ul style="list-style-type: none"> •¹ clear evidence of reflection in $y = 0$ •² clear evidence of translation $\begin{pmatrix} 0 \\ 2 \end{pmatrix}$ subsequent to a reflection •³ indication of passing through $(a, 1)$ and $(b, 2)$ 	<ul style="list-style-type: none"> •⁴ roots at $x = a$ and $x = b$ •⁵ parabolic shape with min. turning point between the roots and no other turning points •⁶ $(0, \frac{1}{2})$
---	--

Differentiate $2\sqrt{x}(x+2)$ with respect to x . 4

part	marks	Unit	non-calc		calc		calc neut		Content Reference :		1.3
			C	A/B	C	A/B	C	A/B	Main	Additional	
.	4	1.3	4						1.3.4		Source 1998 P1 qu.14

<ul style="list-style-type: none"> •¹ know to expand •² $2x^{\frac{3}{2}} + 4x^{\frac{1}{2}}$ •³ $3x^{\frac{1}{2}}$ •⁴ $2x^{-\frac{1}{2}}$

A sketch of part of the graph of $y = \sin 2x$ is shown in the diagram.

The points P and Q have coordinates $(p, 0)$ and $(q, -1)$.

(a) Write down the values of p and q .

(b) Find the area of the shaded region.

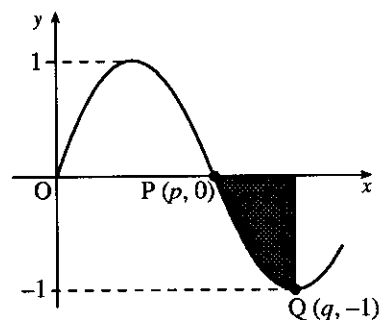

1
4

part	marks	Unit	non-calc		calc		calc neut		Content Reference :		3.2
			C	A/B	C	A/B	C	A/B	Main	Additional	
(a)	1	1.2	1						1.2.3		Source
(b)	4	3.2	1	3					2.2.6	3.2.1	1998 P1 qu.15

• ¹	$p = \frac{\pi}{2}$ and $q = \frac{3\pi}{4}$	• ²	$\int_{\frac{\pi}{2}}^{\frac{3\pi}{4}} (\sin 2x) dx$
		• ³	$-\frac{1}{2} \cos 2x$
		• ⁴	$-\frac{1}{2}$
		• ⁵	deal with - ve correctly giving $\frac{1}{2}$

Given $f(x) = (\sin x + 1)^2$, find the exact value of $f'\left(\frac{\pi}{6}\right)$.

3

part	marks	Unit	non-calc		calc		calc neut		Content Reference :		3.2
			C	A/B	C	A/B	C	A/B	Main	Additional	
.	3	3.2		3					3.2.1	3.2.2	Source
											1998 P1 qu.16

• ¹	$2(\sin x + 1)$	Alternative	• ¹	expand and differentiate $2 \sin x + 1$
• ²	$\times \cos x$		• ²	differentiate $\sin^2 x$
• ³	$\frac{3\sqrt{3}}{2}$		• ³	$\frac{3\sqrt{3}}{2}$

A ball is thrown vertically upwards.

After t seconds its height is h metres, where $h = 1.2 + 19.6t - 4.9t^2$.

(a) Find the speed of the ball after 1 second.

3

(b) For how many seconds is the ball travelling upwards?

2

part	marks	Unit	non-calc		calc		calc neut		Content Reference :		1.3
			C	A/B	C	A/B	C	A/B	Main	Additional	
(a)	3	1.3					1	2	1.3.5	1.3.6	Source
(b)	2	1.3						2	1.3.5	1.3.6	1998 P1 qu.17

<ul style="list-style-type: none"> •¹ $\frac{dh}{dt} = \dots\dots$ •² $19.6 - 9.8t$ •³ 9.8 	<ul style="list-style-type: none"> •⁴ $\frac{dh}{dt} = 0$ •⁵ $t = 2$ 	<p style="text-align: center;">Alternative</p> <ul style="list-style-type: none"> •⁴ $h(t)$ is a parabola which is symmetric about its maximum •⁵ (e.g.) $h(1) = 15.9$, $h(2) = 20.8$, $h(3) = 15.9$ so $t = 2$
---	--	--

(a) Write the equation $\cos 2\theta + 8\cos\theta + 9 = 0$ in terms of $\cos\theta$ and show that, for $\cos\theta$, it has equal roots.

3

(b) Show that there are no real roots for θ .

1

part	marks	Unit	non-calc		calc		calc neut		Content Reference :		2.3
			C	A/B	C	A/B	C	A/B	Main	Additional	
(a)	3	2.3					1	2	2.3.3	2.1.6	Source
(b)	1	1.2						1	1.2.1		1998 P1 qu.18

<ul style="list-style-type: none"> •¹ $2\cos^2\theta - 1 + 8\cos\theta + 9$ •² $2(\cos\theta + 2)^2 = 0$ or $"b^2 - 4ac" = 16 - 4 \times 1 \times 4$ •³ $\cos\theta = -2$ twice or $"b^2 - 4ac" = 0$ 	<ul style="list-style-type: none"> •⁴ $\cos\theta = -2$ has no solution
---	--

Given $x = \log_5 3 + \log_5 4$, find algebraically the value of x .

4

part	marks	Unit	non-calc		calc		calc neut		Content Reference :		3.3
			C	A/B	C	A/B	C	A/B	Main	Additional	
.	4	3.3	1	3					3.3.3	3.3.1, 3.3.4	Source 1998 P1 qu.19

<p>•¹ $x = \log_5 12$</p> <p>•² $5^x = 12$</p> <p>•³ $\log 5^x = \log 12$</p> <p>•⁴ $\frac{\log_{10} 12}{\log_{10} 5}$ <i>or</i> $\frac{\log_e 12}{\log_e 5}$ <i>or</i> $\frac{\log 12}{\log 5} = 1.54$</p>

$P(-4,5)$, $Q(-2,-2)$ and $R(4,1)$ are the vertices of triangle PQR as shown in the diagram. Find the equation of PS , the altitude from P .

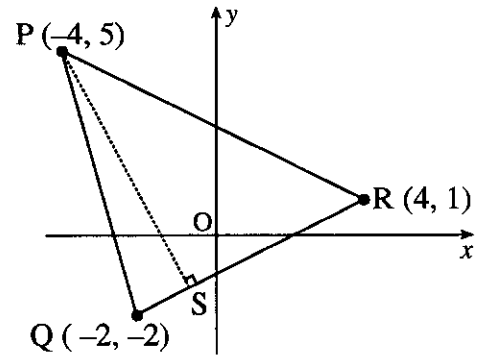

3

part marks	Unit	non-calc		calc		calc neut		Content Reference :		1.1
		C	A/B	C	A/B	C	A/B	Main	Additional	
3	1.1					3		1.1.1	1.1.9, 1.1.7	Source 1997 P1 qu.1

- ¹ $m_{QR} = \frac{1}{2}$
- ² $m_{PN} = -2$
- ³ $PN: y - 4 = -2(x + 3)$

Relative to a suitable set of axes, the tops of three chimneys have coordinates given by $A(1, 3, 2)$, $B(2, -1, 4)$ and $C(4, -9, 8)$. Show that A , B and C are collinear.

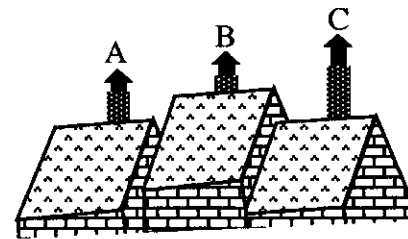

3

part marks	Unit	non-calc		calc		calc neut		Content Reference :		3.1
		C	A/B	C	A/B	C	A/B	Main	Additional	
3	3.1					3		3.1.7		Source 1997 P1 qu.2

- ¹ $\vec{AB} = \begin{pmatrix} 1 \\ -4 \\ 2 \end{pmatrix}$
- ² $\vec{BC} = \begin{pmatrix} 2 \\ -8 \\ 4 \end{pmatrix}$ AND $\vec{BC} = 2 \times \vec{AB}$
- ³ $\vec{AB} \parallel \vec{BC}$ & B is common hence A, B, C collinear

Functions f and g , defined on suitable domains, are given by $f(x) = 2x$ and $g(x) = \sin x + \cos x$.

Find $f(g(x))$ and $g(f(x))$.

4

part	marks	Unit	non-calc		calc		calc neut		Content Reference :		1.2
			C	A/B	C	A/B	C	A/B	Main	Additional	
.	4	1.2	4						1.2.6		Source 1997 P1 qu.3

<ul style="list-style-type: none"> •¹ $f(\sin x + \cos x)$ •² $2(\sin x + \cos x)$ •³ $g(2x)$ •⁴ $\sin 2x + \cos 2x$
--

The position vectors of the points P and Q are $\mathbf{p} = -\mathbf{i} + 3\mathbf{j} + 4\mathbf{k}$ and $\mathbf{q} = 7\mathbf{i} - \mathbf{j} + 5\mathbf{k}$ respectively.

(a) Express \vec{PQ} in component form.

2

(b) Find the length of PQ.

1

part	marks	Unit	non-calc		calc		calc neut		Content Reference :		3.1
			C	A/B	C	A/B	C	A/B	Main	Additional	
(a)	2	3.1					2		3.1.8	3.1.1	Source 1997 P1 qu.4
(b)	1	3.1					1		3.1.3		

<ul style="list-style-type: none"> •¹ $q - p = 8\mathbf{i} - 4\mathbf{j} + \mathbf{k}$ or $p = \begin{pmatrix} -1 \\ 3 \\ 4 \end{pmatrix}, q = \begin{pmatrix} 7 \\ -1 \\ 5 \end{pmatrix}$ •² $\vec{PQ} = \begin{pmatrix} 8 \\ -4 \\ 1 \end{pmatrix}$ •³ 9
--

- (a) Find a real root of the equation $2x^3 - 3x^2 + 2x - 8 = 0$.
 (b) Show algebraically that there are no other real roots.

2
3

part	marks	Unit	non-calc		calc		calc neut		Content Reference :		2.1
			C	A/B	C	A/B	C	A/B	Main	Additional	
(a)	2	2.1	2						2.1.2		Source
(b)	3	2.1	3						2.1.7		1997 P1 qu.5

<ul style="list-style-type: none"> •¹ looking for $f(x) = \dots = 0$ •² $x = 2$ explicitly stated 	<ul style="list-style-type: none"> •³ $2x^2 + x + 4$ •⁴ $b^2 - 4ac = 1 - 4 \times 2 \times 4$ •⁵ $b^2 - 4ac < 0$ means no real roots
---	--

The diagram below shows a parabola with equation $y = 4x^2 + 3x - 5$ and a straight line with equation $5x + y + 12 = 0$.

A tangent to the parabola is drawn parallel to the given straight line.

Find the x -coordinate of the point of contact of this tangent.

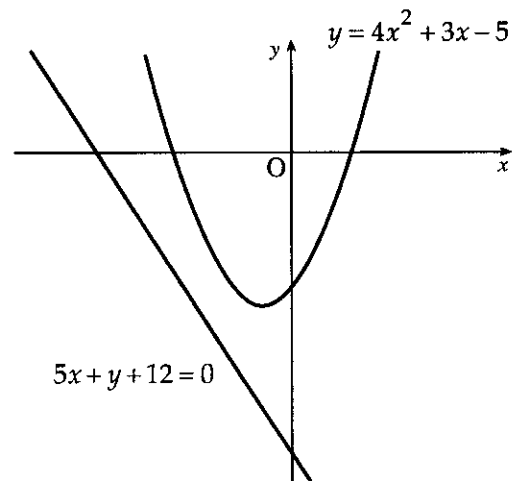

5

part	marks	Unit	non-calc		calc		calc neut		Content Reference :		1.3
			C	A/B	C	A/B	C	A/B	Main	Additional	
.	5	1.3	5						1.1.8	1.3.7	1.3.1
											Source 1997 P1 qu.6

<ul style="list-style-type: none"> •¹ equate gradients •² $m = -5$ •³ $\frac{dy}{dx} = \dots$ •⁴ $\frac{dy}{dx} = 8x + 3$ •⁵ $x = -1$

If x° is an acute angle such that $\tan x^\circ = \frac{4}{3}$, show that the exact value of $\sin(x+30)^\circ$ is $\frac{4\sqrt{3}+3}{10}$.

3

part marks	Unit	non-calc		calc		calc neut		Content Reference :		2.3
		C	A/B	C	A/B	C	A/B	Main	Additional	
3	2.3	3						2.3.2		Source 1997 P1 qu.7

- ¹ $\sin x^\circ \cos 30^\circ + \cos x^\circ \sin 30^\circ$
- ² $\sin x^\circ = \frac{4}{5}$ & $\cos x^\circ = \frac{3}{5}$
- ³ $\frac{4}{5} \cdot \frac{\sqrt{3}}{2} + \frac{3}{5} \cdot \frac{1}{2}$ and completes proof

Given that $y = 2x^2 + x$, find $\frac{dy}{dx}$ and hence show that $x\left(1 + \frac{dy}{dx}\right) = 2y$.

3

part marks	Unit	non-calc		calc		calc neut		Content Reference :		1.3
		C	A/B	C	A/B	C	A/B	Main	Additional	
3	1.3	3						1.3.4		Source 1997 P1 qu.8

- ¹ $\frac{dy}{dx} = 4x + 1$
- ² $LHS = x(1 + 4x + 1)$ or $RHS = 2(2x^2 + x)$
- ³ completes proof

(a) Show that the function $f(x) = 2x^2 + 8x - 3$ can be written in the form $f(x) = a(x+b)^2 + c$ where a, b and c are constants. 3

(b) Hence, or otherwise, find the coordinates of the turning point of the function f . 1

part	marks	Unit	non-calc		calc		calc neut		Content Reference :		1.2
			C	A/B	C	A/B	C	A/B	Main	Additional	
(a)	3	1.2	3						1.2.8		Source
(b)	1		1						1.2.9		1997 P1 qu.9

<ul style="list-style-type: none"> •¹ $a = 2$ •² $b = 2$ •³ $c = -11$ •⁴ $(-2, 11)$

Find the value of $\int_1^4 \sqrt{x} \, dx$. 4

part	marks	Unit	non-calc		calc		calc neut		Content Reference :		2.2
			C	A/B	C	A/B	C	A/B	Main	Additional	
.	4	2.2	4						2.2.5		Source
											1997 P1 qu.10

<ul style="list-style-type: none"> •¹ $x^{\frac{1}{2}}$ •² $x^{\frac{3}{2}} + \frac{3}{2}$ •³ $\frac{2}{3} \left(4^{\frac{3}{2}} - 1^{\frac{3}{2}} \right)$ •⁴ $\frac{14}{3}$
--

Express $2 \sin x^\circ - 5 \cos x^\circ$ in the form $k \sin(x - \alpha)^\circ$, $0 \leq \alpha < 360$ and $k > 0$.

4

part	marks	Unit	non-calc		calc		calc neut		Content Reference :		3.4
			C	A/B	C	A/B	C	A/B	Main	Additional	
.	4	3.4			4				3.4.1		Source 1997 P1 qu.11

- ¹ $k \sin(x - a) = k \sin x \cos a - k \cos x \sin a$ **stated explicitly**
- ² $k \cos a = 2$ **and** $k \sin a = 5$
- ³ $k = \sqrt{29}$
- ⁴ $a = 68.2$

Two identical circles touch at the point P (9, 3) as shown in the diagram. One of the circles has equation $x^2 + y^2 - 10x - 4y + 12 = 0$.

Find the equation of the other circle.

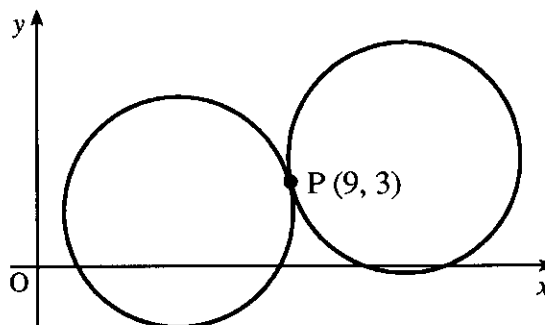

5

part	marks	Unit	non-calc		calc		calc neut		Content Reference :		2.4
			C	A/B	C	A/B	C	A/B	Main	Additional	
.	5	2.4					5		2.4.2	(3.1.6)	Source 1997 P1 qu.12

- ¹ use P as midpoint of C_1C_2
- ² $C_1 = (5, 2)$
- ³ $C_2 = (13, 4)$
- ⁴ radius = $\sqrt{17}$
- ⁵ $(x - 13)^2 + (y - 4)^2 = 17$

PQR is an equilateral triangle of side 2 units.

$\vec{PQ} = \mathbf{a}$, $\vec{PR} = \mathbf{b}$ and $\vec{QR} = \mathbf{c}$.

Evaluate $\mathbf{a} \cdot (\mathbf{b} + \mathbf{c})$ and hence identify two vectors which are perpendicular.

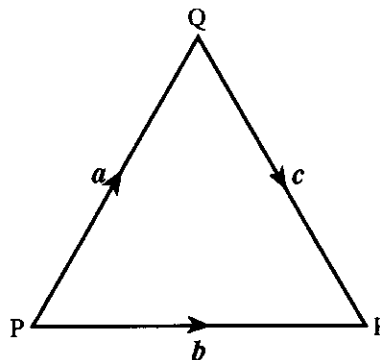

4

part	marks	Unit	non-calc		calc		calc neut		Content Reference :		3.1
			C	A/B	C	A/B	C	A/B	Main	Additional	
.	4	3.1					1	3	3.1.9	3.1.1	Source 1997 P1 qu.13

- ¹ $\mathbf{a} \cdot \mathbf{b} + \mathbf{a} \cdot \mathbf{c}$
- ² $\mathbf{a} \cdot \mathbf{b} = 2 \times 2 \times \frac{1}{2}$
- ³ $\mathbf{a} \cdot \mathbf{c} = 2 \times 2 \times -\frac{1}{2}$
- ⁴ 0 and \mathbf{a} is perpendicular to $(\mathbf{b} + \mathbf{c})$

For what range of values of c does the equation $x^2 + y^2 - 6x + 4y + c = 0$ represent a circle ?

3

part	marks	Unit	non-calc		calc		calc neut		Content Reference :		2.4
			C	A/B	C	A/B	C	A/B	Main	Additional	
.	3	2.4					2	1	2.4.2		Source 1997 P1 qu.14

- ¹ $g^2 + f^2 - c > 0$
- ² $r^2 = 9 + 4 - c$
- ³ $c < 13$

The curve $y = f(x)$ passes through the point $(\frac{\pi}{12}, 1)$ and $f'(x) = \cos 2x$.

Find $f(x)$.

3

part	marks	Unit	non-calc		calc		calc neut		Content Reference :		3.2
			C	A/B	C	A/B	C	A/B	Main	Additional	
.	3	3.2		3					3.2.4		Source 1997 P1 qu.15

<ul style="list-style-type: none"> •¹ $\frac{1}{2} \sin 2x$ •² $1 = \frac{1}{2} \sin \frac{\pi}{6} + c$ •³ $c = \frac{3}{4}$

The diagram shows a sketch of part of the graph of $y = f(x)$. The graph of has a point of inflection at $(0, a)$ and a maximum turning point at (b, c) .

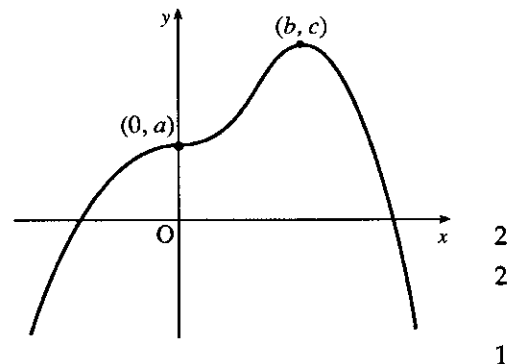

- (a) Make a copy of this diagram and on it sketch the graph of $y = g(x)$ where $g(x) = f(x) + 1$.
- (b) On a separate diagram sketch the graph of $y = f'(x)$.
- (c) Describe how the graph of $y = g'(x)$ is related to the graph of $y = f'(x)$.

part	marks	Unit	non-calc		calc		calc neut		Content Reference :		1.2
			C	A/B	C	A/B	C	A/B	Main	Additional	
(a)	2	1.2	2						1.2.4		Source
(b)	2	1.2	2						1.2.4		1997 P1 qu.16
(c)	1	0.1		1					0.1		

<ul style="list-style-type: none"> •¹ translation $\begin{pmatrix} 0 \\ 1 \end{pmatrix}$ •² annotate $(0, a+1)$ & $(b, c+1)$ 		<ul style="list-style-type: none"> •³ roots at $(0, 0)$ & $(b, 0)$ •⁴ $y' > 0$ for $x < b$, $y' < 0$ for $x > b$ •⁵ they coincide 	
---	--	---	--

Part of the graph of $y = 5 \log_{10}(2x + 10)$ is shown in the diagram. This graph crosses the x -axis at the point A and the straight line $y = 8$ at the point B.

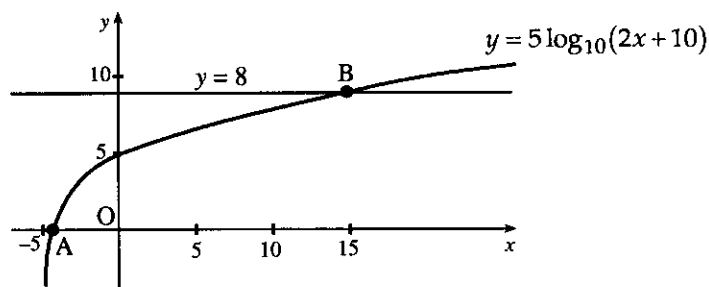

Find algebraically the x -coordinates of A and B.

4

part	marks	Unit	non-calc		calc		calc neut		Content Reference :		3.3
			C	A/B	C	A/B	C	A/B	Main	Additional	
.	4	3.3				4			3.3.4		Source 1997 P1 qu.17

<ul style="list-style-type: none"> •¹ $x_A = -4.5$ •² $5 \log_{10}(2x + 10) = 8$ •³ $2x + 10 = 10^{\frac{8}{5}}$ •⁴ $x = 14.9$
--

(a) Show that $2 \cos 2x^\circ - \cos^2 x^\circ = 1 - 3 \sin^2 x^\circ$.

2

(b) Hence solve the equation $2 \cos 2x^\circ - \cos^2 x^\circ = 2 \sin x^\circ$ in the interval $0 \leq x < 360$.

4

part	marks	Unit	non-calc		calc		calc neut		Content Reference :		2.3
			C	A/B	C	A/B	C	A/B	Main	Additional	
(a)	2	2.3			1	1			2.3.3		Source
(b)	4	2.3			1	3			2.3.5		1997 P1 qu.18

<ul style="list-style-type: none"> •¹ substitute $1 - 2 \sin^2 x^\circ$ for $\cos 2x^\circ$ •² substitute $1 - \sin^2 x^\circ$ for $\cos^2 x^\circ$ •³ $3 \sin^2 x^\circ + 2 \sin x^\circ - 1 = 0$ •⁴ $(3 \sin x^\circ - 1)(\sin x^\circ + 1) = 0$ •⁵ $\sin x^\circ = \frac{1}{3}, -1$ •⁶ $19.5, 160.5, 270$
--

The diagram shows a sketch of part of the graph of $y = a^x, a > 1$.

- (a) If $(1, t)$ and $(u, 1)$ lie on this curve, write down the values of t and u .
 (b) Make a copy of this diagram and on it sketch the graph of $y = a^{2x}$.
 (c) Find the coordinates of the point of intersection of $y = a^{2x}$ with the line $x = 1$.

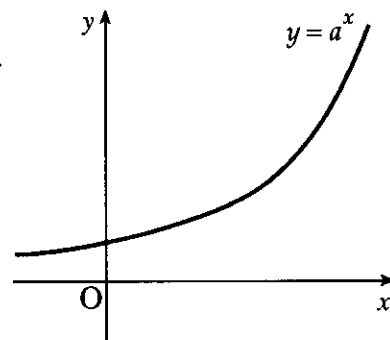

2
2
1

part	marks	Unit	non-calc		calc		calc neut		Content Reference :		3.3
			C	A/B	C	A/B	C	A/B	Main	Additional	
(a)	2	3.3					2		3.3.4		Source
(b)	2	1.2						2	1.2.4		1997 P1 qu.19
(c)	1	0.1					1		0.1		

<ul style="list-style-type: none"> •¹ $t = a$ •² $u = 0$ •³ both passing thr' same point on y-axis •⁴ $y = a^{2x}$ starting below $y = a^x$ and finishing above •⁵ $(1, a^2)$ 	
	<p style="text-align: center;">For mark 3 For mark 4</p>

Diagram 1 shows 5 cars travelling up an incline on a roller-coaster. Part of the roller-coaster rail follows the curve with equation $y = 8 + 5 \cos \frac{1}{2} x$.

Diagram 2 shows an enlargement of the last car and its position relative to a suitable set of axes. The floor of the car lies parallel to the tangent at P , the point of contact. Calculate the acute angle a between the floor of the car and the horizontal when the car is at the point where $x_P = \frac{7\pi}{3}$.

Express your answer in degrees.

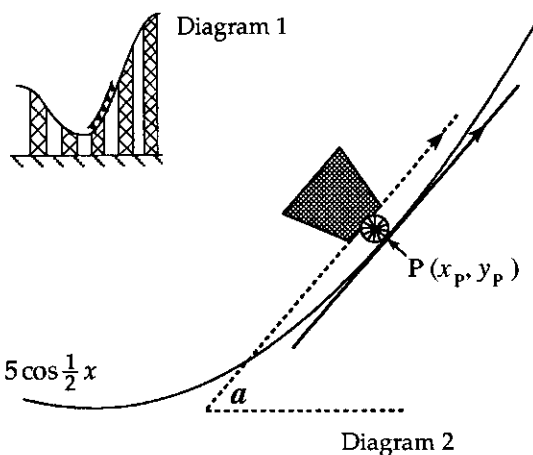

4

part	marks	Unit	non-calc		calc		calc neut		Content Reference :		1.3
			C	A/B	C	A/B	C	A/B	Main	Additional	
.	4	1.3			1	3			1.3.7	1.3.9, 1.1.3	Source
											1997 P1 qu.20

<ul style="list-style-type: none"> •¹ $\frac{dy}{dx} = \dots$ •² $5 \times \left(-\frac{1}{2} \sin \frac{1}{2} x\right)$ •³ $m = \frac{5}{4}$ •⁴ $\theta = 51.3^\circ$
--

Find the equation of the perpendicular bisector of the line joining A(2, -1) and B(8, 3).

4

part marks	Unit	non-calc		calc		calc neut		Content Reference :		1.1
		C	A/B	C	A/B	C	A/B	Main	Additional	
4	1.1					4		1.1.1	1.1.9	Source 1996 P1 qu.1

<ul style="list-style-type: none"> •¹ midpoint = (5,1) •² $m_{AB} = \frac{2}{3}$ •³ $m_{\perp} = -\frac{3}{2}$ •⁴ $y - 1 = -\frac{3}{2}(x - 5)$
--

For what value of a does the equation $ax^2 + 20x + 40 = 0$ have equal roots?

2

part marks	Unit	non-calc		calc		calc neut		Content Reference :		2.1
		C	A/B	C	A/B	C	A/B	Main	Additional	
2	2.1	2						2.1.7		Source 1996 P1 qu.2

<ul style="list-style-type: none"> •¹ $b^2 - 4ac = 0$ •² $a = 2\frac{1}{2}$

The diagram shows an incomplete graph of $y = 3 \sin\left(x - \frac{\pi}{3}\right)$, for $0 \leq x \leq 2\pi$. Find the coordinates of the maximum stationary point.

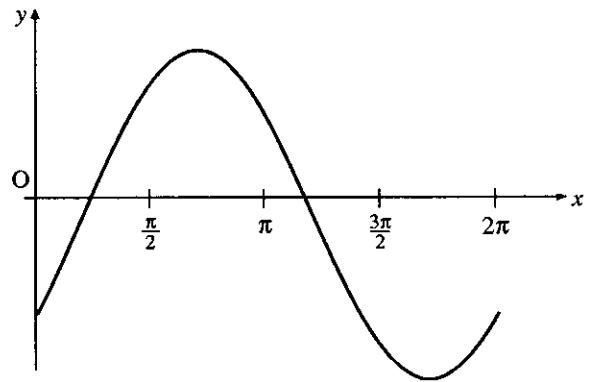

3

part marks	Unit	non-calc		calc		calc neut		Content Reference :		1.2
		C	A/B	C	A/B	C	A/B	Main	Additional	
3	1.2	3						1.2.9		Source 1996 P1 qu.3

- ¹ $y = 3$
- ² compare with $y = \sin x$ or $x - \frac{\pi}{3} = \frac{\pi}{2}$
- ³ $x = \frac{5\pi}{6}$

Find the equation of the tangent at the point (3, 4) on the circle $x^2 + y^2 + 2x - 4y - 15 = 0$.

4

part marks	Unit	non-calc		calc		calc neut		Content Reference :		1.1
		C	A/B	C	A/B	C	A/B	Main	Additional	
4	1.1					4		1.1.1	1.1.9, 2.4.2	Source 1996 P1 qu.4

- ¹ centre = (-1,2)
- ² $m_{radius} = \frac{1}{2}$
- ³ $m_{tgt} = -2$
- ⁴ $y - 4 = -2(x - 3)$

Evaluate $\int_{-3}^0 (2x+3)^2 dx$.

4

part marks	Unit	non-calc		calc		calc neut		Content Reference :		2.2
		C	A/B	C	A/B	C	A/B	Main	Additional	
4	2.2	4						2.2.4	2.2.5	Source 1996 P1 qu.5

• ¹	$\frac{1}{3}(2x+3)^3$					• ¹	$\frac{4}{3}x^3$
• ²	+2			OR		• ²	$6x^2 + 9x$
• ³	$\frac{1}{6}(3)^3 - \frac{1}{6}(-6+3)^3$					• ³	$[0] - \left[\frac{4}{3}(-3)^3 + 6(-3)^2 + 9(-3)\right]$
• ⁴	9					• ⁴	9

A is the point (2, -5, 6), B is (6, -3, 4) and C is (12, 0, 1). Show that A, B and C are collinear and determine the ratio in which B divides AC.

4

part marks	Unit	non-calc		calc		calc neut		Content Reference :		3.1
		C	A/B	C	A/B	C	A/B	Main	Additional	
4	3.1					4		3.1.7	3.1.6	Source 1996 P1 qu.6

• ¹	$\vec{AB} = \begin{pmatrix} 4 \\ 2 \\ -2 \end{pmatrix}$ or $\vec{AC} = \begin{pmatrix} 10 \\ 5 \\ -5 \end{pmatrix}$ or $\vec{BC} = \begin{pmatrix} 6 \\ 3 \\ -3 \end{pmatrix}$	• ³	$AB \parallel BC$ and B is point in common
• ²	$\vec{AB} = 2 \begin{pmatrix} 2 \\ 1 \\ -1 \end{pmatrix}$ and $\vec{BC} = 3 \begin{pmatrix} 2 \\ 1 \\ -1 \end{pmatrix}$ or equivalent	• ⁴	2:3 (or equivalent e.g. 1:1½)

Express $x^4 - x$ in its fully factorised form.

4

part	marks	Unit	non-calc		calc		calc neut		Content Reference :		2.1
			C	A/B	C	A/B	C	A/B	Main	Additional	
.	4	2.1	4						2.1.3		Source 1996 P1 qu.7

<ul style="list-style-type: none"> •¹ $x(x^3 - 1)$ •² synthetic division or eval. $f(k)$ •³ linear factor = $(x - 1)$ •⁴ $x(x - 1)(x^2 + x + 1)$ 	OR	<ul style="list-style-type: none"> •¹ synthetic division or eval. $f(k)$ •² linear factor = $(x - 1)$ •³ cubic factor = $(x^3 + x^2 + x)$ •⁴ $x(x - 1)(x^2 + x + 1)$
--	----	--

Part of the graph of $y = f(x)$ is shown in the diagram.

On separate diagrams sketch the graphs of

- (i) $y = f(x - 1)$
- (ii) $y = -f(x) - 2$

indicating on each graph the images of A, B, C and D.

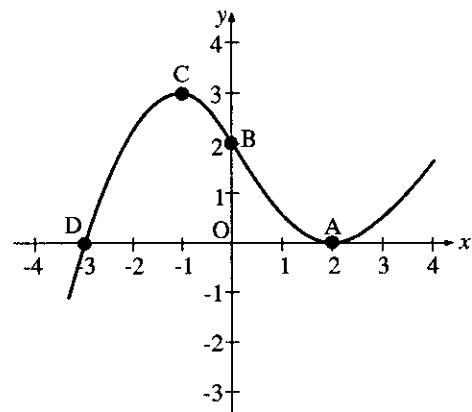

5

part	marks	Unit	non-calc		calc		calc neut		Content Reference :		1.2
			C	A/B	C	A/B	C	A/B	Main	Additional	
(i)	2	1.2					2		1.2.4		Source
(ii)	3	1.2						3	1.2.4		1996 P1 qu.8

<ul style="list-style-type: none"> •¹ translation of $\begin{pmatrix} 1 \\ 0 \end{pmatrix}$ •² $A(3, 0)$ $B(1, 2)$ $C(0, 3)$ $D(-2, 0)$ •³ reflect in x-axis •⁴ translation of $\begin{pmatrix} 0 \\ -2 \end{pmatrix}$ 	<ul style="list-style-type: none"> •⁵ $A(2, -2)$ $B(0, -4)$ $C(-1, -5)$ $D(-3, -2)$ 	
---	---	--

Find $f'(4)$ where $f(x) = \frac{x-1}{\sqrt{x}}$.

5

part marks	Unit	non-calc		calc		calc neut		Content Reference :		1.3
		C	A/B	C	A/B	C	A/B	Main	Additional	
5	1.3	5						1.3.4		Source 1996 P1 qu.9

<ul style="list-style-type: none"> •¹ $\frac{x}{\sqrt{x}} - \frac{1}{\sqrt{x}}$ or $x \times x^{-\frac{1}{2}} - 1 \times x^{-\frac{1}{2}}$ •² $x^{\frac{1}{2}} - x^{-\frac{1}{2}}$ 	<ul style="list-style-type: none"> •³ $\frac{1}{2}x^{-\frac{1}{2}}$ •⁴ $\frac{1}{2}x^{-\frac{3}{2}}$ •⁵ $\frac{5}{16}$
---	---

Solve algebraically the equation $\sin 2x^\circ + \sin x^\circ = 0$, $0 \leq x < 360$.

5

part marks	Unit	non-calc		calc		calc neut		Content Reference :		2.3
		C	A/B	C	A/B	C	A/B	Main	Additional	
5	2.3	5						2.3.5		Source 1996 P1 qu.10

<ul style="list-style-type: none"> •¹ $2 \sin x \cos x + \sin x = 0$ •² $\sin x(2 \cos x + 1) = 0$ •³ $\sin x = 0, \cos x = -\frac{1}{2}$ •⁴ 1st: $x = 0, 180$ •⁵ 2nd: $x = 120, 240$
--

A sequence is defined by the recurrence relation $u_{n+1} = 0.3u_n + 5$ with first term u_1 .

(a) Explain why this sequence has a limit as n tends to infinity.

1

(b) Find the exact value of this limit.

2

part	marks	Unit	non-calc		calc		calc neut		Content Reference :		1.4
			C	A/B	C	A/B	C	A/B	Main	Additional	
(a)	1	1.4					1		1.4.4		Source
(b)	2	1.4					2		1.4.5		1996 P1 qu.11

- ¹ $-1 < 0.3 < 1$
- ² $L = 0.3L + 5$
or $L = \frac{b}{1-a} = \frac{5}{1-0.3}$
- ³ $L = \frac{50}{7}$

The diagram shows a sketch of the graph of $y = \sin\left(2x - \frac{\pi}{6}\right)$, $0 \leq x \leq \pi$, and the straight line $y = 0.5$. These graphs intersect at P and Q.

Find algebraically the coordinates of P and Q.

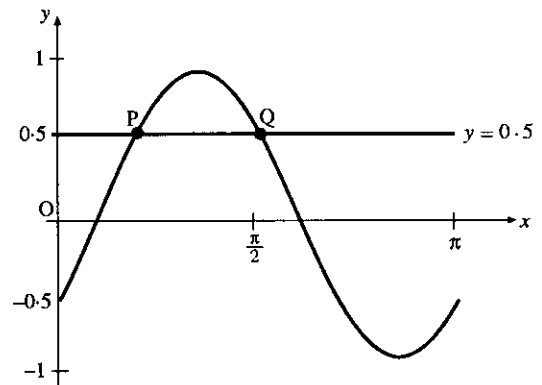

4

part	marks	Unit	non-calc		calc		calc neut		Content Reference :		2.3
			C	A/B	C	A/B	C	A/B	Main	Additional	
.	4	2.3	4						2.3.1	1.2.1	Source
											1996 P1 qu.12

- ¹ $\sin\left(2x - \frac{\pi}{6}\right) = 0.5$ *stated or implied by 2nd mark*
- ² $2x - \frac{\pi}{6} = \frac{\pi}{6}$
- ³ $2x - \frac{\pi}{6} = \frac{5\pi}{6}$
- ⁴ $\left(\frac{\pi}{6}, 0.5\right), \left(\frac{\pi}{2}, 0.5\right)$

Find $\frac{dy}{dx}$ given that $y = \sqrt{1 + \cos x}$.

3

part	marks	Unit	non-calc		calc		calc neut		Content Reference :		3.2
			C	A/B	C	A/B	C	A/B	Main	Additional	
.	3	3.2		3					3.2.2	3.2.1	Source 1996 P1 qu.13

- ¹ $(1 + \cos x)^{\frac{1}{2}}$ stated or implied by •²
- ² $\frac{1}{2}(1 + \cos x)^{-\frac{1}{2}}$
- ³ $x - \sin x$

Three lines have equations $2x + 3y - 4 = 0$, $3x - y - 17 = 0$ and $x - 3y - 10 = 0$.
Determine whether or not these lines are concurrent.

4

part	marks	Unit	non-calc		calc		calc neut		Content Reference :		0.1
			C	A/B	C	A/B	C	A/B	Main	Additional	
.	4	0.1	4						0.1		Source 1996 P1 qu.14

- ¹ know to solve 2 equ & check in 3rd
- ² 1 coord. of $(5, -2)$ or $(\frac{14}{3}, -\frac{16}{9})$ or $(\frac{41}{8}, -\frac{13}{8})$
- ³ second appropriate coordinate
- ⁴ checking $(5, -2)$ does not lie on 3rd line or $(\frac{14}{3}, -\frac{16}{9})$ not on 2nd line or $(\frac{41}{8}, -\frac{13}{8})$ not on 1st line

The diagram shows two right-angled triangles ABD and BCD with AB = 7cm, BC = 4cm and CD = 3cm. Angle DBC = x° and angle ABD = y° .

Show that the exact value of $\cos(x+y)^\circ$ is $\frac{20-6\sqrt{6}}{35}$.

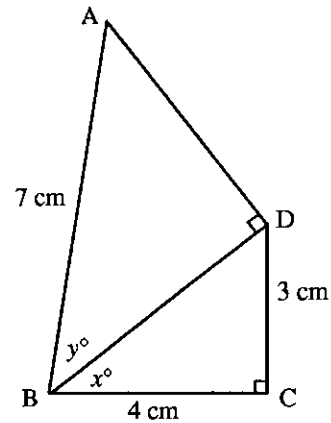

3

part marks	Unit	non-calc		calc		calc neut		Content Reference :		2.3
		C	A/B	C	A/B	C	A/B	Main	Additional	
3	2.3					3		2.3.2		Source 1996 P1 qu.15

- ¹ know to calculate missing sides
- ² $BD = 5$, $AD = \sqrt{24}$
- ³ $\cos x \cos y - \sin x \sin y = \frac{4}{5} \cdot \frac{5}{7} - \frac{3}{5} \cdot \frac{\sqrt{24}}{7}$

Find algebraically the values of x for which the function $f(x) = 2x^3 - 3x^2 - 36x$ is increasing.

4

part marks	Unit	non-calc		calc		calc neut		Content Reference :		2.1
		C	A/B	C	A/B	C	A/B	Main	Additional	
4	2.1	2	2					1.3.11	2.1.9	Source 1996 P1 qu.16

- ¹ know to consider $f'(x) > 0$ stated or implied by the evidence for •⁴.
- ² $\frac{dy}{dx} = 6x^2 - 6x - 36$
- ³ $6(x-3)(x+2) > 0$ or by formula or completing the square
- ⁴ $x < -2$, $x > 3$

Express $f(x) = (2x - 1)(2x + 5)$ in the form $a(x + b)^2 + c$.

3

part	marks	Unit	non-calc		calc		calc neut		Content Reference :		1.2
			C	A/B	C	A/B	C	A/B	Main	Additional	
.	3	1.2	3						1.2.8		Source 1996 P1 qu.17

<ul style="list-style-type: none"> •¹ $4x^2 + 8x - 5$ •² $4(x+1)^2$ •³ $c = -9$ 	<p>Strategy: expand $a(x+b)^2 + c$ and compare coefficients</p> <ul style="list-style-type: none"> •¹ $4x^2 + 8x - 5$ •² $a = 4$ and $b = 1$ •³ $c = -9$
--	---

The framework of a child's swing has dimensions as shown in the diagram on the right. Find the exact value of $\sin x^\circ$.

5

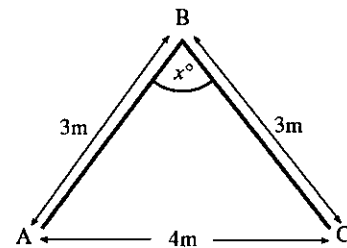
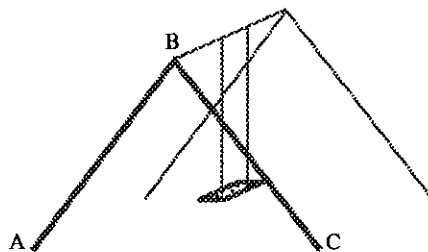

part	marks	Unit	non-calc		calc		calc neut		Content Reference :		2.3
			C	A/B	C	A/B	C	A/B	Main	Additional	
.	5	2.3	1	4					2.3.4		Source 1996 P1 qu.18

<ul style="list-style-type: none"> •¹ sketch with $\frac{x}{2}$ marked in r/a Δ •² height of triangle = $\sqrt{5}$ •³ $\sin x = 2 \sin \frac{1}{2}x \cos \frac{1}{2}x$ •⁴ $\sin \frac{x}{2} = \frac{2}{3}$ and $\cos \frac{1}{2}x = \frac{\sqrt{5}}{3}$ •⁵ $\sin x = \frac{4\sqrt{5}}{9}$ 	OR	<ul style="list-style-type: none"> •¹ know to use cosine rule •² $\cos x = \frac{3^2 + 3^2 - 4^2}{2 \cdot 3 \cdot 3}$ •³ $\frac{1}{9}$ •⁴ draw r/a Δ or use $\cos^2 x + \sin^2 x = 1$ •⁵ $\sin x = \frac{\sqrt{80}}{9}$
---	----	---

A mug of tea cools according to the law $T_t = T_0 e^{-kt}$ where T_0 is the initial temperature and T_c is the temperature after t minutes. All temperatures are in $^{\circ}\text{C}$.

- (a) A particular mug of tea cooled from boiling point (100°C) to 75°C in a quarter of an hour.
Calculate the value of k . 3
- (b) By how many degrees will the temperature of this tea fall in the next quarter of an hour? 2

part	marks	Unit	non-calc		calc		calc neut		Content Reference :		3.3
			C	A/B	C	A/B	C	A/B	Main	Additional	
(a)	3	3.3			1	2			3.3.7		Source 1996 P1 qu.19
(b)	2	3.3				2		3.3.7			

- | | |
|--|---|
| <ul style="list-style-type: none"> •¹ $75 = 100e^{-k \times 15}$ •² $\ln 0.75 = -15k$ •³ $k = 0.0192$ | <ul style="list-style-type: none"> •⁴ $T_{15} = 75e^{-0.0192 \times 15}$ or $T_{30} = 100e^{-0.0192 \times 30}$ •⁵ fall = 18.75 |
|--|---|

The line $y = -1$ is a tangent to a circle which passes through $(0, 0)$ and $(6, 0)$.
Find the equation of this circle. 6

part	marks	Unit	non-calc		calc		calc neut		Content Reference :		2.4
			C	A/B	C	A/B	C	A/B	Main	Additional	
.	6	2.4					1	5	2.4.3	0.1	Source 1996 P1 qu.20

- | | | |
|--|--|---|
| <ul style="list-style-type: none"> •¹ sketch with point of con.P = $(3, -1)$ •² Centre $C = (3, y)$ •³ $CO^2 = CP^2$ •⁴ $y = 4$ •⁵ radius = 5 •⁶ $(x-3)^2 + (y-4)^2 = 25$ | <p>OR</p> <ul style="list-style-type: none"> •¹ $(x-3)^2 + (y-k)^2 = r^2$ •² $r^2 = k^2 + 9$ •³ $(x-3)^2 + (-1-k)^2 = r^2$ has '=' roots •⁴ reduce to $x^2 - 6x + (2k+1)$ •⁵ $k = 4$ •⁶ $(x-3)^2 + (y-4)^2 = 25$ | <p>OR</p> <ul style="list-style-type: none"> •¹ sketch with point of con.P = $(3, -1)$ •² $x^2 + y^2 + 2gx + 2fy + c = 0$ •³ $(0, 0) \Rightarrow c = 0$ •⁴ $(6, 0) \Rightarrow g = -3$ •⁵ $(3, -1) \Rightarrow f = -4$ •⁶ $x^2 + y^2 - 6x - 8y = 0$ |
|--|--|---|

Calculate the length of the vector $2\mathbf{i} - 3\mathbf{j} + \sqrt{3}\mathbf{k}$.

2

part	marks	Unit	non-calc		calc		calc neut		Content Reference :		3.1
			C	A/B	C	A/B	C	A/B	Main	Additional	
.	2	3.1					2		3.1.8		Source 1995 P1 qu.1

<p>•¹ $\sqrt{2^2 + (-3)^2 + (\sqrt{3})^2}$ stated or implied by •²</p> <p>•² 4</p>
--

(a) Show that $(x - 3)$ is a factor of $f(x)$ where $f(x) = 2x^3 + 3x^2 - 23x - 12$.

2

(b) Hence express $f(x)$ in its fully factorised form.

2

part	marks	Unit	non-calc		calc		calc neut		Content Reference :		2.1
			C	A/B	C	A/B	C	A/B	Main	Additional	
(a)	2	2.1	2						2.1.3		Source
(b)	2	2.1	2						2.1.3		1995 P1 qu.2

<p>•¹ $f(3) = 2 \times 3^3 + 3 \times 3^2 - 23 \times 3 - 12$ or equivalent division</p> <p>•² = 0</p> <p>•³ $2x^2 + 9x + 4$</p> <p>•⁴ $(x - 3)(2x + 1)(x + 4)$</p>
--

Find $\int (6x^2 - x + \cos x) dx$.

4

part	marks	Unit	non-calc		calc		calc neut		Content Reference :		3.2
			C	A/B	C	A/B	C	A/B	Main	Additional	
.	4	3.2	4						3.2.4		Source 1995 P1 qu.3

• ¹	$2x^3$
• ²	$-\frac{1}{2}x^2$
• ³	$\sin x$
• ⁴	$+c$

Find the value of k for which the vectors $\begin{pmatrix} 1 \\ 2 \\ -1 \end{pmatrix}$ and $\begin{pmatrix} -4 \\ 3 \\ k-1 \end{pmatrix}$ are perpendicular.

3

part	marks	Unit	non-calc		calc		calc neut		Content Reference :		3.1
			C	A/B	C	A/B	C	A/B	Main	Additional	
.	3	3.1					3		3.1.10		Source 1995 P1 qu.4

• ¹	$\begin{pmatrix} 1 \\ 2 \\ -1 \end{pmatrix} \cdot \begin{pmatrix} -4 \\ 3 \\ k-1 \end{pmatrix} = 0$
• ²	$1 \times -4 + 2 \times 3 + -1(k-1)$
• ³	3

Find the equation of the median AD of triangle ABC where the coordinates of A, B and C are (-2, 3), (-3, -4) and (5, 2) respectively.

3

part marks	Unit	non-calc		calc		calc neut		Content Reference :		1.1
		C	A/B	C	A/B	C	A/B	Main	Additional	
3	1.1					3		1.1.7	1.1.1	Source 1995 P1 qu.5

<ul style="list-style-type: none"> •¹ D = (1, -1) •² use A and D to get $m_{AD} = -\frac{4}{3}$ •³ $y - 3 = -\frac{4}{3}(x - -2)$ 	OR ┃ ┃ ┃	<ul style="list-style-type: none"> •¹ for showing triangle isosceles •² $m_{BC} = \frac{3}{4}$ giving $m_{AD} = -\frac{4}{3}$ •³ $y - 3 = -\frac{4}{3}(x - -2)$
---	--------------------------	--

A Royal Navy submarine exercising in the Firth of Clyde is stationary on the seabed below a point S on the surface. S is the point (5, 4) as shown.

A radar operator observes the frigate 'Achilles' sailing in a straight line, passing through the points A₁ (-4, -1) and A₂ (-1, 1). Similarly the frigate 'Belligerent' is observed sailing in a straight line, passing through the points B₁ (-7, -11) and B₂ (1, -1).

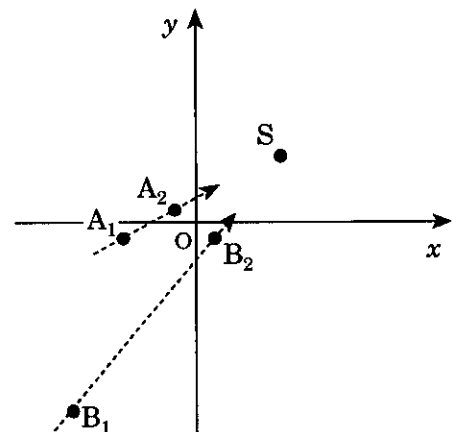

If both frigates continue to sail in straight lines, will either or both frigates pass directly over the submarine ?

5

part marks	Unit	non-calc		calc		calc neut		Content Reference :		1.1
		C	A/B	C	A/B	C	A/B	Main	Additional	
5	1.1					5		1.1.10		Source 1995 P1 qu.6

<ul style="list-style-type: none"> •¹ strat: compare gradients •² $m_{A_1A_2} = \frac{2}{3}$ •³ $m_{A_2S} = \frac{1}{2}$ or $m_{A_1S} = \frac{5}{9}$ so not heading for S •⁴ $m_{B_1B_2} = \frac{5}{4}$ •⁵ $m_{B_2S} = \frac{5}{4}$ or $m_{B_1S} = \frac{5}{4}$ so heading for S 	┃ ┃ ┃ ┃ ┃	<ul style="list-style-type: none"> •¹ strat: st lines and substitution •² $A_1A_2: y + 1 = \frac{2}{3}(x + 4)$ or equivalent •³ $4 + 1 \neq \frac{2}{3}(5 + 4)$ so not heading for S •⁴ $B_1B_2: y + 11 = \frac{5}{4}(x + 7)$ or equivalent •⁵ $4 + 11 = \frac{5}{4}(5 + 7)$ so heading for S
--	-----------------------	---

Find $\frac{dy}{dx}$ where $y = \frac{4}{x^2} + x\sqrt{x}$.

4

part marks	Unit	non-calc		calc		calc neut		Content Reference :		1.3
		C	A/B	C	A/B	C	A/B	Main	Additional	
4	1.3	4						1.3.4		Source 1995 P1 qu.7

• ¹	$4x^{-2}$	stated or implied by	• ³
• ²	$+x^{\frac{3}{2}}$	stated or implied by	• ⁴
• ³	$-8x^{-3}$		
• ⁴	$+\frac{3}{2}x^{\frac{1}{2}}$		

Find the exact solutions of the equation $4\sin^2 x = 1$, $0 \leq x < 2\pi$.

4

part marks	Unit	non-calc		calc		calc neut		Content Reference :		2.3
		C	A/B	C	A/B	C	A/B	Main	Additional	
4	2.3	4						2.3.1	1.2.1	Source 1995 P1 qu.8

• ¹	know to factorise, take square roots		• ¹	replace $\sin^2 x$ by $\frac{1}{2}(1 - \cos 2x)$
• ²	$\sin x = \frac{1}{2}$		• ²	$\cos 2x = \frac{1}{2}$
• ³	$x = \frac{\pi}{6}, \frac{5\pi}{6}$		• ³	$2x = \frac{\pi}{3}, \frac{5\pi}{3}, \frac{7\pi}{3}, \frac{11\pi}{3}$
• ⁴	$\sin x = -\frac{1}{2}$ and $x = \frac{7\pi}{6}, \frac{11\pi}{6}$		• ⁴	$x = \frac{\pi}{6}, \frac{5\pi}{6}, \frac{7\pi}{6}, \frac{11\pi}{6}$

Find the equation of the circle which has P(-2, -1) and Q(4, 5) as the end points of a diameter.

3

part	marks	Unit	non-calc		calc		calc neut		Content Reference :		2.4
			C	A/B	C	A/B	C	A/B	Main	Additional	
.	3	2.4					3		2.4.3		Source 1995 P1 qu.9

- ¹ (1,2)
- ² $\sqrt{(4-1)^2 + (5-2)^2}$ or equiv.
- ³ $(x-1)^2 + (y-2)^2 = 18$ or equiv.

The point P(-2, b) lies on the graph of the function $f(x) = 3x^3 - x^2 - 7x + 4$.

(a) Find the value of b.

1

(b) Prove that this function is increasing at P.

3

part	marks	Unit	non-calc		calc		calc neut		Content Reference :		1.3
			C	A/B	C	A/B	C	A/B	Main	Additional	
(a)	1	0.1	1						0.1		Source
(b)	3	1.3	3						1.3.11		1995 P1 qu.10

- ¹ $b = -10$
- ² know to differentiate **and** know to show $\frac{dy}{dx}_{x=-2} > 0$
- ³ $9x^2 - 2x - 7$
- ⁴ show that $\frac{dy}{dx}_{x=-2} > 0$

The functions f and g , defined on suitable domains, are given by $f(x) = \frac{1}{x^2 - 4}$ and $g(x) = 2x + 1$.

- (a) Find an expression for $h(x)$ where $h(x) = g(f(x))$. Give your answer as a single fraction. 3
 (b) State a suitable domain for h . 1

part	marks	Unit	non-calc		calc		calc neut		Content Reference :		1.2
			C	A/B	C	A/B	C	A/B	Main	Additional	
(a)	3	1.2	2	1					1.2.6		Source 1995 P1 qu.11
(b)	1	1.2		1					1.2.1		

• ¹	$g\left(\frac{1}{x^2 - 4}\right)$	• ³	$\frac{x^2 - 2}{x^2 - 4}$
• ²	$2\left(\frac{1}{x^2 - 4}\right) + 1$	• ⁴	"any domain which excludes 2"

Given that $\tan \alpha = \frac{\sqrt{11}}{3}$, $0 < \alpha < \frac{1}{2}\pi$, find the exact value of $\sin 2\alpha$. 3

part	marks	Unit	non-calc		calc		calc neut		Content Reference :		2.3
			C	A/B	C	A/B	C	A/B	Main	Additional	
.	3	2.3	3						2.3.3		Source 1995 P1 qu.12

• ¹	"third side" = $\sqrt{20}$
• ²	$\sin \alpha = \frac{\sqrt{11}}{\sqrt{20}}$ or $\cos \alpha = \frac{3}{\sqrt{20}}$
• ³	$2 \times \frac{\sqrt{11}}{\sqrt{20}} \times \frac{3}{\sqrt{20}}$

Solve the simultaneous equations $k \sin x^\circ = 5$

$k \cos x^\circ = 2$ where $k \geq 0$ and $0 \leq x \leq 360$

4

part marks	Unit	non-calc		calc		calc neut		Content Reference :		3.4
		C	A/B	C	A/B	C	A/B	Main	Additional	
4	3.4			4				3.4.1		Source 1995 P1 qu.13

<ul style="list-style-type: none"> •¹ $\tan x = \frac{5}{2}$ •² $x = 68.2$ •³ $k^2 = 25 + 4$ or $k = \frac{5}{\sin 68.2}$ •⁴ $k = \sqrt{29}$ 	<div style="border-left: 2px dashed black; height: 100px; margin: 0 auto;"></div>	<ul style="list-style-type: none"> •¹ $k^2(\sin^2 x + \cos^2 x) = 29$ •² $k = \sqrt{29}$ •³ $\tan x = \frac{5}{2}$ or $\sin x = \frac{5}{\sqrt{29}}$ •⁴ $x = 68.2$
---	---	---

The straight line shown in the diagram has equation $y = f(x)$.

Determine $f'(x)$.

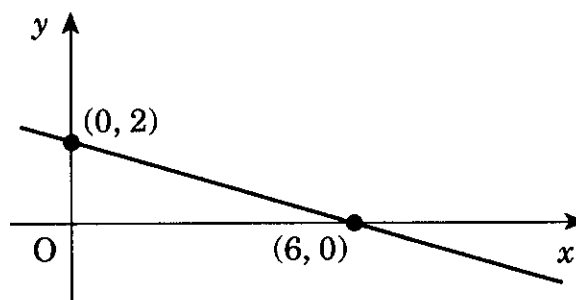

2

part marks	Unit	non-calc		calc		calc neut		Content Reference :		1.3
		C	A/B	C	A/B	C	A/B	Main	Additional	
2	1.3	2						1.3.7		Source 1995 P1 qu.14

<ul style="list-style-type: none"> •¹ gradient = $-\frac{1}{3}$ •² $f'(x) = \text{gradient}$
--

part marks	Unit	non-calc		calc		calc neut		Content Reference :		2.3
		C	A/B	C	A/B	C	A/B	Main	Additional	
5	2.3				5			2.3.5		Source 1995 P1 qu.15

<ul style="list-style-type: none"> •¹ substitute $2\cos^2 x^\circ - 1$ for $\cos 2x^\circ$ •² $(2\cos x^\circ - 1)(\cos x^\circ + 1) = 0$ •³ $\cos x^\circ = \frac{1}{2}$, $\cos x^\circ = -1$ •⁴ $x = 60, 300$ •⁵ $x = 180$

In the square-based pyramid, all the eight edges are of length 3 units.

$\vec{AV} = \mathbf{p}$, $\vec{AD} = \mathbf{q}$, $\vec{AB} = \mathbf{r}$.

Evaluate $\mathbf{p} \cdot (\mathbf{q} + \mathbf{r})$.

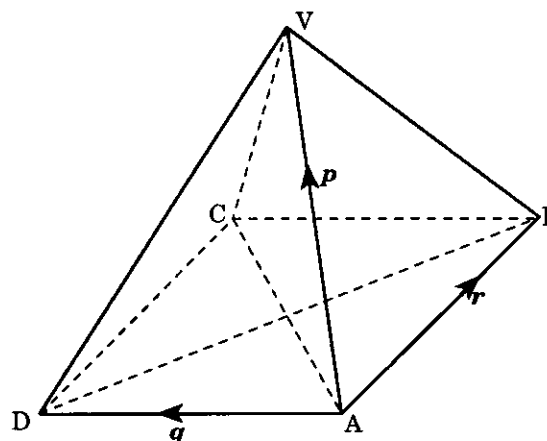

4

part marks	Unit	non-calc		calc		calc neut		Content Reference :		3.1
		C	A/B	C	A/B	C	A/B	Main	Additional	
4	3.1					1	3	3.1.9		Source 1995 P1 qu.16

<ul style="list-style-type: none"> •¹ $\mathbf{p} \cdot \mathbf{q} + \mathbf{p} \cdot \mathbf{r}$ •² $\widehat{VAD} = 60^\circ$ or equiv. •³ $\mathbf{p} \mathbf{q} \cos \widehat{VAD} + \mathbf{p} \mathbf{r} \cos \widehat{VAB}$ •⁴ 9 	<ul style="list-style-type: none"> •¹ $\mathbf{r} = \begin{pmatrix} 0 \\ 3 \\ 0 \end{pmatrix}, \mathbf{q} = \begin{pmatrix} -3 \\ 0 \\ 0 \end{pmatrix}$ •² $\mathbf{p} = \begin{pmatrix} -\frac{3}{2} \\ \frac{3}{2} \\ \frac{3}{\sqrt{2}} \end{pmatrix}$ •³ $(-\frac{3}{2}) \times (-3) + (\frac{3}{2}) \times 3 + \frac{3}{\sqrt{2}} \times 0$ •⁴ 9
--	--

Part of the graph of $y = f(x)$ is shown in the diagram. This graph has stationary points at $x = 0$, $x = a$ and $x = b$.

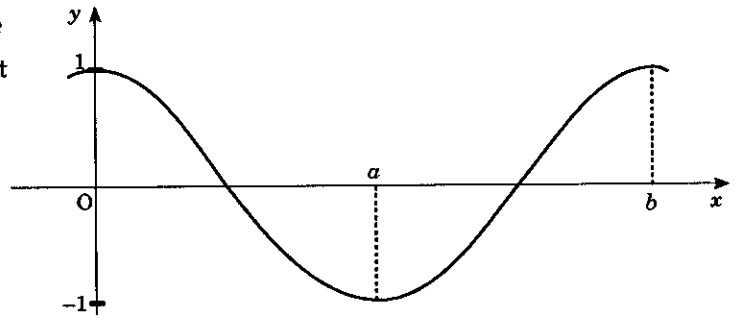

- (a) Sketch the graph of $y = f'(x)$ for $0 \leq x \leq b$.
 (b) If $a = \pi$ and $b = 2\pi$, write down a possible expression for $f'(x)$.

3
1

part	marks	Unit	non-calc		calc		calc neut		Content Reference :		1.2
			C	A/B	C	A/B	C	A/B	Main	Additional	
(a)	3	1.2					2	1	1.2.4		Source
(b)	1	1.2						1	1.2.4		1995 P1 qu.17

- ¹ sketch to have zeroes at $x = 0, a, b$
- ² $f(x) < 0$ for $0 < x < a$ and a minimum turning point in $0 < x < a$
- ³ $f(x) > 0$ for $a < x < b$ and a maximum turning point in $a < x < b$
- ⁴ e.g. $f'(x) = -\sin x$, $f'(x) = \cos(x + 90)$, $f'(x) = \sin(x - 180)$, $f'(x) = kx(x - \pi)(x - 2\pi)$

The amount A grams of a radioactive substance at time t minutes is given by $A = A_0 e^{-kt}$ where A_0 is the initial amount of the substance and k is a constant.

In 3 minutes, 10 grams of the substance Bismuth are reduced to 9 grams through radioactive decay.

- (a) Find the value of k .

3

The half-life of a substance is the length of time in which half the substance decays.

- (b) Find the half-life of Bismuth.

2

part	marks	Unit	non-calc		calc		calc neut		Content Reference :		3.3
			C	A/B	C	A/B	C	A/B	Main	Additional	
(a)	3	3.3			1	2			3.3.7		Source
(b)	2	3.3				2			3.3.7		1995 P1 qu.18

- ¹ $9 = 10e^{-3k}$
- ² $-3k = \log_e 0.9$
- ³ 0.04
- ⁴ $e^{-kt} = 0.5$
- ⁵ a correct value for t

The diagram shows a sketch of the graph of $y = f(x)$ where $f(x) = a \log_2(x - b)$.
Find the values of a and b .

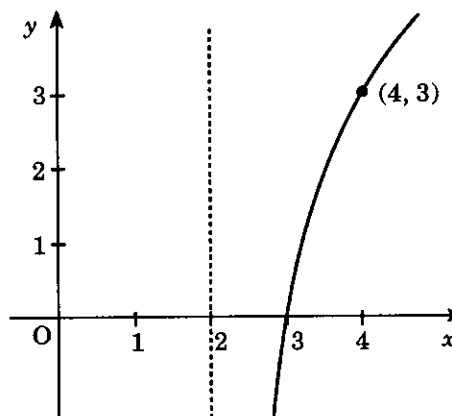

3

part marks	Unit	non-calc		calc		calc neut		Content Reference :		3.3
		C	A/B	C	A/B	C	A/B	Main	Additional	
3	3.3						3	3.3.4		Source 1995 P1 qu.19

- ¹ $b = 2$
- ² $3 = a \log_2 2$ stated or implied
or $(4 - b)^a = 8$
- ³ $a = 3$

The roots of the equation $(x - 1)(x + k) = -4$ are equal.
Find the values of k .

5

part marks	Unit	non-calc		calc		calc neut		Content Reference :		2.1
		C	A/B	C	A/B	C	A/B	Main	Additional	
5	2.1					1	4	2.1.7		Source 1995 P1 qu.20

- ¹ $x^2 + kx - x + 4 - k = 0$
- ² $b^2 - 4ac = 0$
- ³ $(k - 1)^2 - 4(4 - k)$
- ⁴ $k^2 + 2k - 15 = 0$
- ⁵ $k = -5, k = 3$

A ball is thrown vertically upwards. The height h metres of the ball t seconds after it is thrown, is given by the formula $h = 20t - 5t^2$.

- (a) Find the speed of the ball when it is thrown (i.e. the rate of change of height with respect to time of the ball when it is thrown). 3
- (b) Find the speed of the ball after 2 seconds. 2
 Explain your answer in terms of the movement of the ball.

part	marks	Unit	non-calc		calc		calc neut		Content Reference :		1.3
			C	A/B	C	A/B	C	A/B	Main	Additional	
(a)	3	1.3	1	2					1.3.6		Source
(b)	2	1.2		2					1.2.9		1995 P1 qu.21

<ul style="list-style-type: none"> •¹ knows to differentiate •² $20 - 10t$ •³ 20 •⁴ speed = 0 •⁵ ball stationary at top of flight
--

Find $\int (3x^3 + 4x) dx$.

3

part	marks	Unit	non-calc		calc		calc neut		Content Reference :		2.2
			C	A/B	C	A/B	C	A/B	Main	Additional	
.	3	2.2	3						2.2.4		Source 1994 P1 qu.1

• ¹	$\frac{3}{4}x^4$
• ²	$2x^2$
• ³	$+c$

If $f(x) = kx^3 + 5x - 1$ and $f'(1) = 14$, find the value of k .

3

part	marks	Unit	non-calc		calc		calc neut		Content Reference :		1.3
			C	A/B	C	A/B	C	A/B	Main	Additional	
.	3	1.3	3						1.3.4	0.1	Source 1994 P1 qu.2

• ¹	$f'(x) = 3kx^2 + 5$
• ²	$f'(1) = 3k + 5$
• ³	$k = 3$

A is the point (2, -1, 4), B is (7, 1, 3) and C is (-6, 4, 2). If ABCD is a parallelogram, find the coordinates of D.

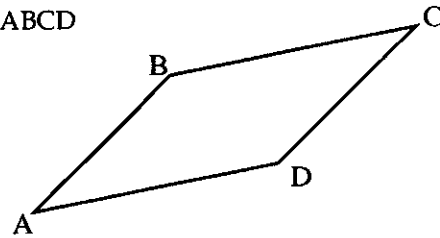

3

part	marks	Unit	non-calc		calc		calc neut		Content Reference :		3.1
			C	A/B	C	A/B	C	A/B	Main	Additional	
.	3	3.1					3		3.1.4	3.1.1	Source 1994 P1 qu.3

<ul style="list-style-type: none"> •¹ $\vec{OD} = \vec{OA} + \vec{AD}$ or equivalent, stated or implied by •³ •² $\vec{BC} = \begin{pmatrix} -13 \\ 3 \\ -1 \end{pmatrix}$ or \vec{CB} or \vec{AB} or \vec{BA} •³ D = (-11, 2, 3) 	OR	<ul style="list-style-type: none"> •¹ $\vec{OD} = \vec{OM} + \vec{MD}$, M is midpoint of AC •² $\vec{BM} = \begin{pmatrix} -9 \\ \frac{1}{2} \\ 0 \end{pmatrix}$ •³ D = (-11, 2, 3)
---	----	---

Relative to the top of a hill, three gliders have positions given by R(-1, -8, -2), S(2, -5, 4) and T(3, -4, 6). Prove that R, S and T are collinear.

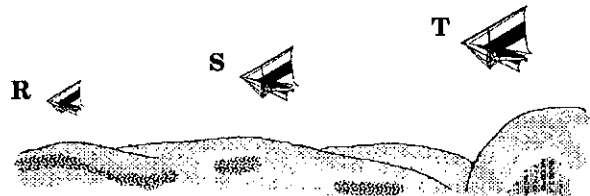

3

part	marks	Unit	non-calc		calc		calc neut		Content Reference :		3.1
			C	A/B	C	A/B	C	A/B	Main	Additional	
.	3	3.1					3				Source 1994 P1 qu.4

<ul style="list-style-type: none"> •¹ $\vec{ST} = \begin{pmatrix} 1 \\ 1 \\ 2 \end{pmatrix}$ or equivalent and $\vec{RS} = \begin{pmatrix} 3 \\ 3 \\ 6 \end{pmatrix}$ or equivalent •² $\vec{RS} = 3\vec{ST}$ or equiv. •³ RS // ST and S is common.

The circle shown in the diagram has equation

$$(x-1)^2 + (y-1)^2 = 5.$$

Tangents are drawn at the points $(3, 2)$ and $(2, -1)$.

Write down the coordinates of the centre of the circle and hence show that the tangents are perpendicular to each other.

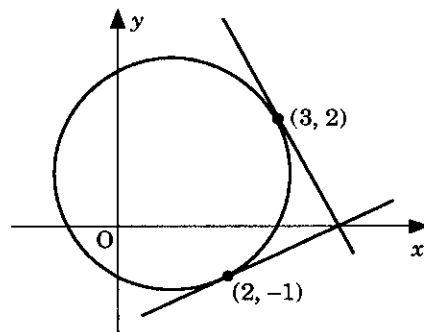

4

part	marks	Unit	non-calc		calc		calc neut		Content Reference :		2.4
			C	A/B	C	A/B	C	A/B	Main	Additional	
.	4	2.4					4		2.4.1	1.1.9	Source 1994 P1 qu.5

<ul style="list-style-type: none"> •¹ centre = $(1, 1)$ •² $m_{\text{radii}} = \frac{1}{2}, -2$ •³ $m_{\text{tgts}} = -2, \frac{1}{2}$ •⁴ $-2 \times \frac{1}{2} = -1 \Rightarrow$ tgts are \perp 	OR	<ul style="list-style-type: none"> •¹ centre = $(1, 1)$ •² $r = \sqrt{5}, d = \sqrt{10}$ •³ Show $\hat{ACB} = 90^\circ$ •⁴ State tangents \perp to radii 	
--	----	--	--

Find algebraically the exact value of $\sin \theta^\circ + \sin(\theta + 120)^\circ + \cos(\theta + 150)^\circ$.

3

part	marks	Unit	non-calc		calc		calc neut		Content Reference :		2.3
			C	A/B	C	A/B	C	A/B	Main	Additional	
.	3	2.3	3						2.3.2		Source 1994 P1 qu.6

<ul style="list-style-type: none"> •¹ $\sin \theta \cos 120 + \cos \theta \sin 120$ and $\cos \theta \cos 150 - \sin \theta \sin 150$ •² correct use of exact values •³ simplification to zero

If $\mathbf{u} = \begin{pmatrix} -3 \\ 3 \\ 3 \end{pmatrix}$ and $\mathbf{v} = \begin{pmatrix} 1 \\ 5 \\ -1 \end{pmatrix}$, write down the components of $\mathbf{u} + \mathbf{v}$ and $\mathbf{u} - \mathbf{v}$. Hence show that

$\mathbf{u} + \mathbf{v}$ and $\mathbf{u} - \mathbf{v}$ are perpendicular.

3

part	marks	Unit	non-calc		calc		calc neut		Content Reference :		3.1
			C	A/B	C	A/B	C	A/B	Main	Additional	
.	3	3.1					3		3.1.2	3.1.1	Source 1994 P1 qu.7

•¹ $\mathbf{u} + \mathbf{v} = \begin{pmatrix} -2 \\ 8 \\ 2 \end{pmatrix}$ and $\mathbf{u} - \mathbf{v} = \begin{pmatrix} -4 \\ -2 \\ 4 \end{pmatrix}$

•² $(\mathbf{u} + \mathbf{v}) \cdot (\mathbf{u} - \mathbf{v}) = 8 - 16 + 8$

•³ $(\mathbf{u} + \mathbf{v}) \cdot (\mathbf{u} - \mathbf{v}) = 0$ so $\mathbf{u} + \mathbf{v}$ and $\mathbf{u} - \mathbf{v}$ are perpendicular

The straight line $y = x$ cuts the circle

$$x^2 + y^2 - 6x - 2y - 24 = 0 \text{ at A and B.}$$

(a) Find the coordinates of A and B.

(b) Find the equation of the circle which has AB as diameter.

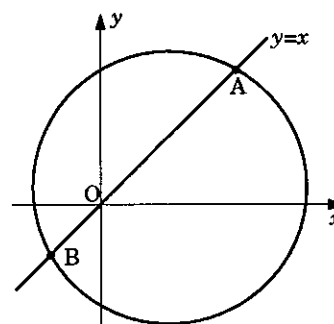

3
3

part	marks	Unit	non-calc		calc		calc neut		Content Reference :		2.4
			C	A/B	C	A/B	C	A/B	Main	Additional	
(a)	3	2.4					3		2.4.4		Source
(b)	3	2.4					3		2.4.3		1994 P1 qu.8

•¹ $x^2 + x^2 - 6x - 2x - 24 = 0$

•² $(x+2)(x-6) = 0$

•³ $(-2, -2)$ and $(6, 6)$

OR

•⁴ centre is $(2, 2)$

•⁵ radius is $\sqrt{32}$ or equivalent

•⁶ $(x-2)^2 + (y-2)^2 = 32$

A sequence is defined by the recurrence relation $u_n = 0.9u_{n-1} + 2$, $u_1 = 3$.

(a) Calculate the value of u_2 .

1

(b) What is the smallest value of n for which $u_n > 10$?

1

(c) Find the limit of this sequence as $n \rightarrow \infty$.

2

part	marks	Unit	non-calc		calc		calc neut		Content Reference :		1.4
			C	A/B	C	A/B	C	A/B	Main	Additional	
(a)	1	1.4			1				1.4.2		Source 1994 P1 qu.9
(b)	1	1.4			1			1.4.3			
(c)	2	1.4			2			1.4.5			

• ¹	4.7								
• ²	7								
• ³	$l = 0.9l + 2$			OR				• ³	$l = \frac{b}{1-a} = \frac{2}{1-0.9}$
• ⁴	20							• ⁴	20

Find the derivative, with respect to x , of $\frac{1}{x^3} + \cos 3x$.

4

part	marks	Unit	non-calc		calc		calc neut		Content Reference :		3.2
			C	A/B	C	A/B	C	A/B	Main	Additional	
.	4	3.2		4					3.2.2		Source 1994 P1 qu.10

• ¹	x^{-3} stated or implied by • ²
• ²	$-3x^{-4}$
• ³	$-\sin 3x$
• ⁴	$\times 3$

Show that $x^2 + 8x + 18$ can be written in the form $(x+a)^2 + b$.
Hence or otherwise find the coordinates of the turning point of the curve
with equation $y = x^2 + 8x + 18$.

3

part	marks	Unit	non-calc		calc		calc neut		Content Reference :		1.2
			C	A/B	C	A/B	C	A/B	Main	Additional	
.	3	1.2	3						1.2.8	1.2.9	Source 1994 P1 qu.11

<ul style="list-style-type: none"> •¹ $a = 4$ •² $b = 2$ •³ $(-4, 2)$
--

The diagram shows the graph of the function $y = a + b \sin cx$ for $0 \leq x \leq \pi$.

- (a) Write down the values of a , b and c .
(b) Find algebraically the values of x for which $y = 2.5$.

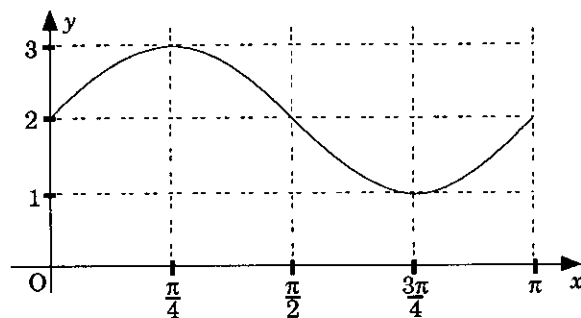

3
3

part	marks	Unit	non-calc		calc		calc neut		Content Reference :		2.3
			C	A/B	C	A/B	C	A/B	Main	Additional	
(a)	3	1.2	3						1.2.3		Source
(b)	3	2.3	3						2.3.1	1.2.11	1994 P1 qu.12

<ul style="list-style-type: none"> •¹ $a = 2$ •² $b = 1$ •³ $c = 2$ 	<ul style="list-style-type: none"> •⁴ $2 + \sin 2x = 2\frac{1}{2}$ •⁵ $2x = \frac{\pi}{6}, \frac{5\pi}{6}$ •⁶ $x = \frac{\pi}{12}, \frac{5\pi}{12}$ (0.262, 1.309) 	OR	<ul style="list-style-type: none"> •⁴ $2 + \sin 2x = 2\frac{1}{2}$ •⁵ $2x = \frac{\pi}{6}, x = \frac{\pi}{12}$ •⁶ $2x = \frac{5\pi}{6}, x = \frac{5\pi}{12}$
--	---	----	---

If $\cos \theta = \frac{4}{5}$, $0 \leq \theta < \frac{\pi}{2}$, find the exact value of

(a) $\sin 2\theta$

(b) $\sin 4\theta$.

2

3

part	marks	Unit	non-calc		calc		calc neut		Content Reference :		2.3
			C	A/B	C	A/B	C	A/B	Main	Additional	
(a)	2	2.3	2						2.3.3		Source
(b)	3	2.3		3					2.3.3		1994 P1 qu.13

• ¹	$\sin \theta = \frac{3}{5}$	• ³	$2 \sin 2\theta \cos 2\theta$
• ²	$\frac{24}{25}$	• ⁴	$\cos 2\theta = \frac{7}{25}$
		• ⁵	$\frac{336}{625}$

Find the gradient of the tangent to the parabola

$y = 4x - x^2$ at $(0,0)$.

Hence calculate the size of the angle between the line

$y = x$ and this tangent.

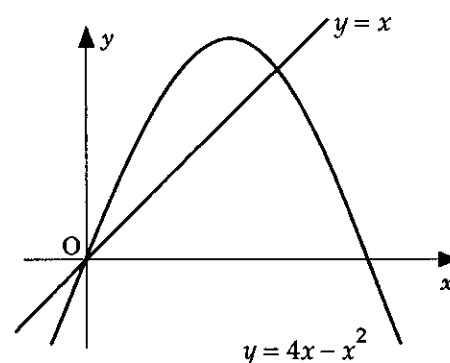

6

part	marks	Unit	non-calc		calc		calc neut		Content Reference :		1.3
			C	A/B	C	A/B	C	A/B	Main	Additional	
.	6	1.3	6						1.3.9	1.1.3	Source
											1994 P1 qu.14

• ¹	know to differentiate	• ⁴	76°
• ²	$4 - 2x$	• ⁵	45°
• ³	$m = 4$	• ⁶	31°

part	marks	Unit	non-calc		calc		calc neut		Content Reference :		2.3
			C	A/B	C	A/B	C	A/B	Main	Additional	
.	5	2.3			1	4			2.3.5		Source 1994 P1 qu.15

• ¹	Replacing $\cos 2x$ by $2\cos^2 x - 1$	• ⁵	300°
• ²	$2\cos^2 x + 5\cos x - 3 = 0$	and	no extraneous solutions
• ³	$(2\cos x - 1)(\cos x + 3) = 0$	and	no solution for $\cos x = -3$ indicated.
• ⁴	60°	[If a reason is given, it must be valid].	

The diagram shows a sketch of part of the graph of $y = \log_5 x$.

- (a) Make a copy of the graph of $y = \log_5 x$.
 On your copy, sketch the graph of $y = \log_5 x + 1$.
 Find the coordinates of the point where it crosses the x -axis.

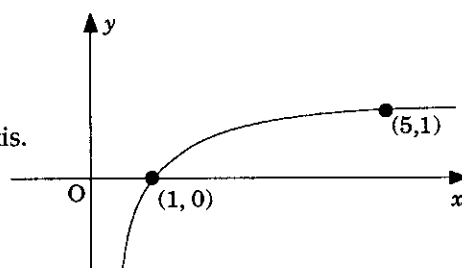

- (b) Make a second copy of the graph of $y = \log_5 x$.
 On your copy, sketch the graph of $y = \log_5 \frac{1}{x}$.

part	marks	Unit	non-calc		calc		calc neut		Content Reference :		3.3
			C	A/B	C	A/B	C	A/B	Main	Additional	
(a)	3	3.3	2	1					3.3.4	1.2.4	Source
(b)	2	3.3		2					3.3.2	1.2.4	1994 P1 qu.16

• ¹	sketch of new function	• ⁴	$\log_5 \frac{1}{x} = -\log_5 x$
• ²	$\log_5 x + 1 = 0$	• ⁵	reflect in x -axis
• ³	$(\frac{1}{5}, 0)$		

Differentiate $\sin^3 x$ with respect to x .

Hence find $\int \sin^2 x \cos x \, dx$.

4

part marks	Unit	non-calc		calc		calc neut		Content Reference :		3.2
		C	A/B	C	A/B	C	A/B	Main	Additional	
4	3.2	1	3					3.2.2	2.2.3	Source 1994 P1 qu.17

<ul style="list-style-type: none"> •¹ using $(\sin x)^3$ stated or implied by •² •² $3 \sin^2 x$ •³ $\times \cos x$ •⁴ $\frac{1}{3} \sin^3 x$
--

The diagram shows a point P with coordinates (4, 2, 6) and two points S and T which lie on the x-axis. If P is 5 units from S and 7 units from T, find the coordinates of S and T.

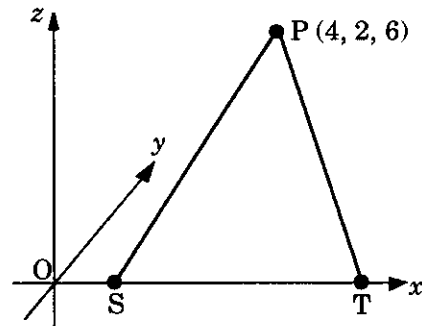

3

part marks	Unit	non-calc		calc		calc neut		Content Reference :		3.1
		C	A/B	C	A/B	C	A/B	Main	Additional	
3	3.1						3	3.1.3		Source 1994 P1 qu.18

<ul style="list-style-type: none"> •¹ $(x, 0, 0)$ or equiv. OR •¹ $PQ = \sqrt{40}$ OR •¹ $d^2 = 7^2 - 6^2 - 2^2$ •² $(x - 4)^2 + 4 + 36 = 49$ or equiv. •² $d = 3$ •² $d = 3$ •³ $x = 1, 7$ •³ $(1, 0, 0), (7, 0, 0)$ •³ $(1, 0, 0), (7, 0, 0)$
--

A function f is defined on the set of real numbers by $f(x) = \frac{x}{1-x}$, ($x \neq 1$).

Find, in its simplest form, an expression for $f(f(x))$.

3

part marks	Unit	non-calc		calc		calc neut		Content Reference :		1.2
		C	A/B	C	A/B	C	A/B	Main	Additional	
3	1.2	1	2					1.2.6		Source 1994 P1 qu.19

•¹ $f\left(\frac{x}{1-x}\right)$

•² $\frac{\frac{x}{1-x}}{1-\frac{x}{1-x}}$

•³ $\frac{x}{1-2x}$

The diagram shows part of the graph with equation $y = 3^x$ and the straight line with equation $y = 42$. These graphs intersect at P.

Solve algebraically the equation $3^x = 42$, and hence write down, correct to 3 decimal places, the coordinates of P.

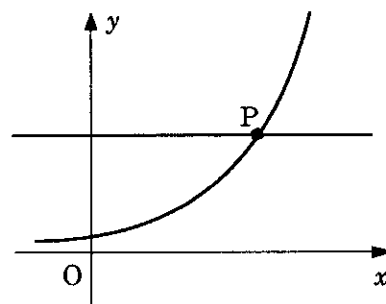

4

part marks	Unit	non-calc		calc		calc neut		Content Reference :		3.3
		C	A/B	C	A/B	C	A/B	Main	Additional	
4	3.3				4			3.3.4		Source 1994 P1 qu.20

•¹ use logs

OR

•¹ use logs

OR

•¹ use exponentials

•² $\ln 3^x = \ln 42$

•² $x = \log_3 42$

•² $(e^{1.0986})^x = 42$

•³ $x \ln 3 = \ln 42$

•³ $x = \frac{\ln 42}{\ln 3}$

•³ $1.0986x = \ln 42$

•⁴ 3.402

•⁴ 3.402

•⁴ 3.402

A is the point $(-3,2,4)$ and B is $(-1,3,2)$. Find

- (a) the components of vector \vec{AB} ;
 (b) the length of AB.

1
2

part	marks	Unit	non-calc		calc		calc neut		Content Reference :		3.1
			C	A/B	C	A/B	C	A/B	Main	Additional	
(a)	1	3.1					1		3.1.1		Source 1993 P1 qu.1
(b)	2	3.1					2		3.1.3		

<p>•¹ $\begin{pmatrix} 2 \\ 1 \\ -2 \end{pmatrix}$</p> <p>•² $\sqrt{(-3+1)^2 + (2-3)^2 + (4-2)^2}$</p> <p>•³ 3</p>

Relative to the axes shown and with an appropriate scale, Alex stands at the point $(-2, 3)$ where Hartington Road meets Newport Road.

- (a) Find the equation of Newport Road which is perpendicular to Hartington Road.
 (b) Brenda is waiting for a bus at the point $(-5, 1)$. Show that Brenda is standing on Newport Road.

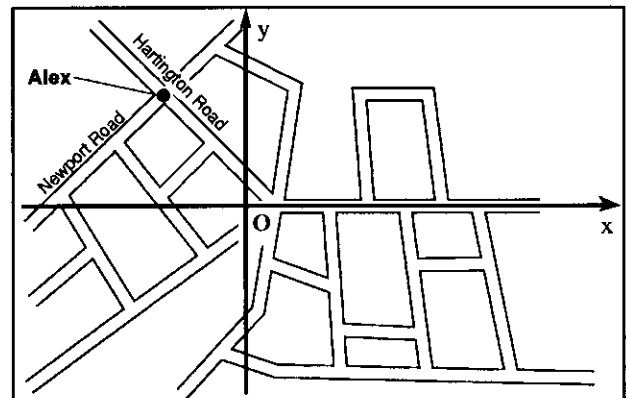

3
1

part	marks	Unit	non-calc		calc		calc neut		Content Reference :		1.1
			C	A/B	C	A/B	C	A/B	Main	Additional	
(a)	3	1.1					3		1.1.7	1.1.9	Source 1993 P1 qu.2
(b)	1	1.2					1		(1.2.9)		

<p>•¹ $m_{OA} = -\frac{3}{2}$</p> <p>•² $m_{\perp} = \frac{2}{3}$</p> <p>•³ $y - 3 = \frac{2}{3}(x + 2)$</p> <p>•⁴ verify that $(-5, -1)$ lies on this line</p>

Find the values of k for which the equation $2x^2 + 4x + k = 0$ has real roots.

2

part marks	Unit	non-calc		calc		calc neut		Content Reference :		2.1
		C	A/B	C	A/B	C	A/B	Main	Additional	
2	2.1	2						2.1.7		Source 1993 P1 qu.3

- ¹ discriminant = $16 - 4 \times 2 \times k$
- ² $16 - 8k \geq 0$ for real roots $\Rightarrow k \leq 2$

Find the x -coordinate of each of the points on the curve $y = 2x^3 - 3x^2 - 12x + 20$ at which the tangent is parallel to the x -axis.

4

part marks	Unit	non-calc		calc		calc neut		Content Reference :		1.3
		C	A/B	C	A/B	C	A/B	Main	Additional	
4	1.3	4						1.3.10		Source 1993 P1 qu.4

- ¹ $\frac{dy}{dx} = \dots\dots$
- ² $6x^2 - 6x - 12$
- ³ $\dots\dots = 0$
- ⁴ $x = -1, 2$

This diagram shows a computer-generated display of a game of noughts and crosses.

Relative to the coordinate axes which have been added to the display, the "nought" at A is represented by a circle with equation $(x - 2)^2 + (y - 2)^2 = 4$.

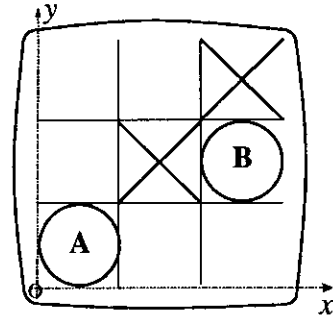

- (a) Find the centre of the circle at B.
 (b) Find the equation of the circle at B.

3
1

part	marks	Unit	non-calc		calc		calc neut		Content Reference :		2.4
			C	A/B	C	A/B	C	A/B	Main	Additional	
(a)	3	2.4					3		2.4.1		Source
(b)	1	2.4					1		2.4.3		1993 P1 qu.5

<ul style="list-style-type: none"> •¹ $radius_A = 2$ •² $centre_A = (2, 2)$ •³ $centre_B = (10, 6)$ •⁴ $(x - 10)^2 + (y - 6)^2 = 4$

For acute angles P and Q, $\sin P = \frac{12}{13}$ and $\sin Q = \frac{3}{5}$.

Show that the exact value of $\sin(P + Q)$ is $\frac{63}{65}$.

3

part	marks	Unit	non-calc		calc		calc neut		Content Reference :		2.3
			C	A/B	C	A/B	C	A/B	Main	Additional	
.	3	2.3	3						2.3.2		Source
											1993 P1 qu.6

<ul style="list-style-type: none"> •¹ $\cos P = \frac{5}{13}$ •² $\cos Q = \frac{4}{5}$ •³ $\frac{12}{13} \times \frac{4}{5} + \frac{5}{13} \times \frac{3}{5}$
--

One root of the equation $2x^3 - 3x^2 + px + 30 = 0$ is -3 .
 Find the value of p and the other roots.

4

part marks	Unit	non-calc		calc		calc neut		Content Reference :		2.1
		C	A/B	C	A/B	C	A/B	Main	Additional	
4	2.1	4						2.1.2		Source 1993 P1 qu.7

<ul style="list-style-type: none"> •¹ $f(-3) = -54 - 27 - 3p + 30$ or synth. division e.g. •² $p = -17$ •³ $2x^2 - 9x + 10$ •⁴ $2, \frac{5}{2}$ 	$\begin{array}{r rrrr} -3 & 2 & -3 & p & 30 \\ & & -6 & 27 & -3p-81 \\ \hline & 2 & -9 & p+27 & -3p-51 \end{array}$ <p>and $-3p - 51 = 0$</p>
---	---

The diagram shows the graph of $y = f(x)$.
 Sketch the graph of $y = 2 - f(x)$.

3

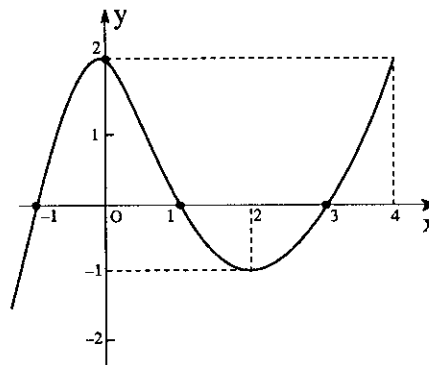

part marks	Unit	non-calc		calc		calc neut		Content Reference :		1.2
		C	A/B	C	A/B	C	A/B	Main	Additional	
3	1.2	1	2					1.2.4		Source 1993 P1 qu.8

<ul style="list-style-type: none"> •¹ reflection in Ox •² translation $\begin{pmatrix} 0 \\ 2 \end{pmatrix}$ •³ two trans. in correct order, annotate diagram 	
--	--

part	marks	Unit	non-calc		calc		calc neut		Content Reference :		3.2
			C	A/B	C	A/B	C	A/B	Main	Additional	
.	4	3.2	2	2					3.2.2	1.3.4	Source 1993 P1 qu.9

<ul style="list-style-type: none"> •¹ $4x^{\frac{1}{2}}$ •² $2x^{-\frac{1}{2}}$ •³ $-\sin 2x$ •⁴ $\times 2$

The lines $y = 2x + 4$ and $x + y = 13$ make angles of a° and b° with the positive direction of the x -axis, as shown in the diagram.

- (a) Find the values of a and b .
 (b) Hence find the acute angle between the two given lines.

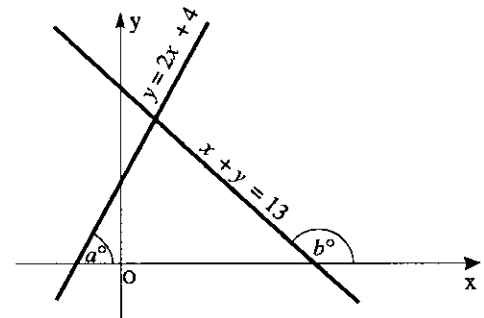

4
1

part	marks	Unit	non-calc		calc		calc neut		Content Reference :		1.1
			C	A/B	C	A/B	C	A/B	Main	Additional	
(a)	4	1.1			4				1.1.3		Source
(b)	1	0.1			1				0.1		1993 P1 qu.10

<ul style="list-style-type: none"> •¹ $\tan a^\circ = 2$ •² $a = 63.4^\circ$ •³ $\tan(180 - b) = 1$ •⁴ $b = 135$ •⁵ $180 - a - (180 - b)$ or equiv. to $b - a$
--

The graphs of $y = f(x)$ and $y = g(x)$ intersect at the point A on the y -axis, as shown in the diagram.

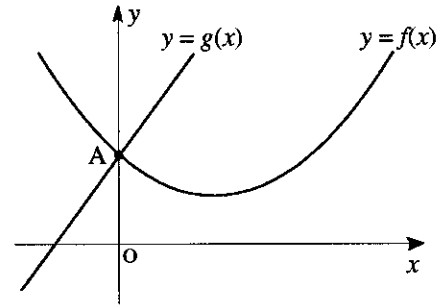

If $g(x) = 3x + 4$
and $f'(x) = 2x - 3$, find $f(x)$.

4

part marks	Unit	non-calc		calc		calc neut		Content Reference :		2.2
		C	A/B	C	A/B	C	A/B	Main	Additional	
4	2.2	4						2.2.4	1.2.9	Source 1993 P1 qu.11

<ul style="list-style-type: none"> •¹ $\int f'(x)dx$ •² $x^2 - 3x$ •³ use (0,4) to find c •⁴ $f(x) = x^2 - 3x + 4$

The vectors a , b and c are defined as follows:

$$a = 2i - k, \quad b = i + 2j + k, \quad c = -j + k.$$

(a) Evaluate $a \cdot b + a \cdot c$.

3

(b) From your answer to part (a), make a deduction about the vector $b + c$.

2

part marks	Unit	non-calc		calc		calc neut		Content Reference :		3.1
		C	A/B	C	A/B	C	A/B	Main	Additional	
(a)	3					3		3.1.8	3.1.9	Source 1993 P1 qu.12
(b)	2						2	3.1.10		

<ul style="list-style-type: none"> •¹ $a = \begin{pmatrix} 2 \\ 0 \\ -1 \end{pmatrix}, b = \begin{pmatrix} 1 \\ 2 \\ 1 \end{pmatrix}, c = \begin{pmatrix} 0 \\ -1 \\ 1 \end{pmatrix}$ •² $a \cdot b = 1$ •³ $a \cdot c = -1$ •⁴ $a \cdot b + a \cdot c = a \cdot (b + c)$ •⁵ $a \perp b + c$

$$f(x) = 2x - 1, \quad g(x) = 3 - 2x \quad \text{and} \quad h(x) = \frac{1}{4}(5 - x).$$

- (a) Find a formula for $k(x)$ where $k(x) = f(g(x))$. 2
- (b) Find a formula for $h(k(x))$. 2
- (c) What is the connection between the functions h and k ? 1

part	marks	Unit	non-calc		calc		calc neut		Content Reference :		1.2
			C	A/B	C	A/B	C	A/B	Main	Additional	
(a)	2	1.2	2						1.2.6		Source 1993 P1 qu.13
(b)	2	1.2	2						1.2.6		
(c)	1	0.1		1					0.1		

<ul style="list-style-type: none"> •¹ $f(3 - 2x)$ •² $5 - 4x$ •³ $h(5 - 4x)$ •⁴ x •⁵ inverse of each other
--

A sketch of a cubic function, f , with domain $-4 \leq x \leq 4$, is shown in the diagram below.

Sketch the graph of the derived function, f' , for the same domain.

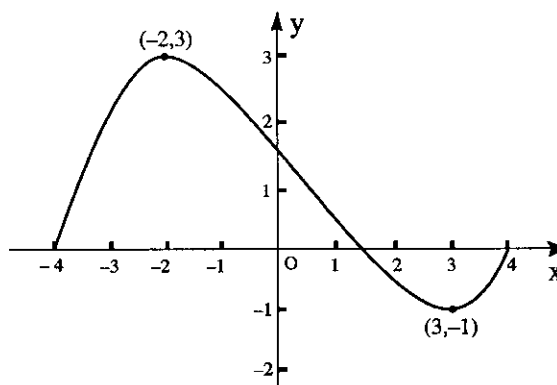

3

part	marks	Unit	non-calc		calc		calc neut		Content Reference :		1.2
			C	A/B	C	A/B	C	A/B	Main	Additional	
.	3	1.2	3						1.2.4	1.2.1	Source 1993 P1 qu.14

<ul style="list-style-type: none"> •¹ $(-2, 0)$ and $(3, 0)$ •² know how to find sign of f' over 3 intervals •³ min tp between $x = -2$ and $x = 3$ and no other

A medical technician obtains this print-out of a wave form generated by an oscilloscope. The technician knows that the equation of the first branch of the graph (for $0 \leq x \leq 3$) should be of the form $y = ae^{kx}$.

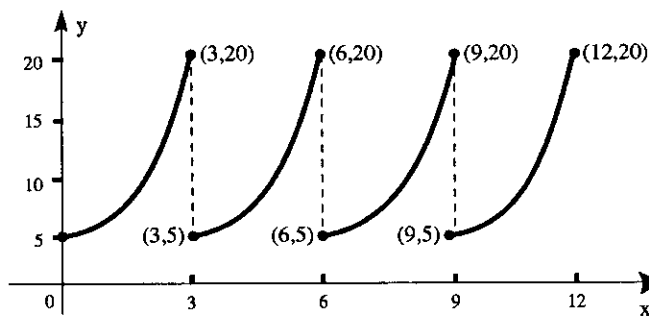

- (a) Find the values of a and k . 4
- (b) Find the equation of the second branch of the curve (i.e. for $3 \leq x \leq 6$). 1

part	marks	Unit	non-calc		calc		calc neut		Content Reference :		3.3
			C	A/B	C	A/B	C	A/B	Main	Additional	
(a)	4	3.3			1	3			3.3.5		Source 1993 P1 qu.15
(b)	1	1.2				1		1.2.7			

- ¹ $(0, 5) \Rightarrow a = 5$
- ² $20 = 5e^{3k}$
- ³ e.g. $\ln 20 = \ln 5 + 3k \ln e$
- ⁴ $k = 0.462$ (Accept $\frac{1}{3} \ln 4$)
- ⁵ $y = 5e^{k(x-3)}$

Find $\int \sqrt{1+3x} \, dx$ and hence find the exact value of $\int_0^1 \sqrt{1+3x} \, dx$. 4

part	marks	Unit	non-calc		calc		calc neut		Content Reference :		3.2
			C	A/B	C	A/B	C	A/B	Main	Additional	
.	4	3.2		4					3.2.3		Source 1993 P1 qu.16

- ¹ $(1+3x)^{\frac{1}{2}}$
- ² $\frac{1}{\frac{3}{2}}(1+3x)^{\frac{3}{2}}$
- ³ $+ 3$
- ⁴ $\frac{14}{9}$

If $f(a) = 6 \sin^2 a - \cos a$, express $f(a)$ in the form $p \cos^2 a + q \cos a + r$.

Hence solve, correct to three decimal places, the equation $6 \sin^2 a - \cos a = 5$ for $0 \leq a \leq \pi$.

4

part marks	Unit	non-calc		calc		calc neut		Content Reference :		2.3
		C	A/B	C	A/B	C	A/B	Main	Additional	
4	2.3			2	2			2.3.1		Source 1993 P1 qu.17

- ¹ subst. leading from \sin^2 to \cos^2
- ² $-6 \cos^2 a - \cos a + 6 = 5$
- ³ solving the quadratic
- ⁴ 1.231 and 2.094

Explain why the equation $x^2 + y^2 + 2x + 3y + 5 = 0$ does not represent a circle.

2

part marks	Unit	non-calc		calc		calc neut		Content Reference :		2.4
		C	A/B	C	A/B	C	A/B	Main	Additional	
2	2.4					2		2.4.2		Source 1993 P1 qu.18

- ¹ $g^2 + f^2 - c = -1\frac{3}{4}$
- ² $r = \sqrt{-1\frac{3}{4}}$ which is not possible

(a) Show that $(\cos x + \sin x)^2 = 1 + \sin 2x$.

1

(b) Hence find $\int (\cos x + \sin x)^2 dx$.

3

part	marks	Unit	non-calc		calc		calc neut		Content Reference :		3.2
			C	A/B	C	A/B	C	A/B	Main	Additional	
(a)	1	2.3	1						2.3.3		Source
(b)	3	3.2		3					3.2.4		1993 P1 qu.19

<ul style="list-style-type: none"> •¹ $\sin^2 x + \cos^2 x + 2 \sin x \cos x$ and complete •² $x + c$ •³ $-\cos 2x$ •⁴ $\times \frac{1}{2}$

The point P (p, k) lies on the curve with equation $y = \ln x$.

The point Q (q, k) lies on the curve with equation $y = \frac{1}{2} \ln x$.

Find a relationship between p and q and hence find q when $p = 5$.

4

part	marks	Unit	non-calc		calc		calc neut		Content Reference :		3.3
			C	A/B	C	A/B	C	A/B	Main	Additional	
.	4	3.3					1	3	3.3.5		Source
											1993 P1 qu.20

<ul style="list-style-type: none"> •¹ $k = \log_e p$ and $k = \frac{1}{2} \log_e q$ •² $\log p = \frac{1}{2} \log q$ or $p = e^k$ and $q = e^{2k}$ •³ $q = p^2$ or $p = q^{\frac{1}{2}}$ •⁴ $q = 25$
--

The diagram shows the graph of the function

$$f(x) = \frac{1}{x+1}, \quad x \neq -1.$$

Prove that the function f is decreasing for all values of x except $x = -1$.

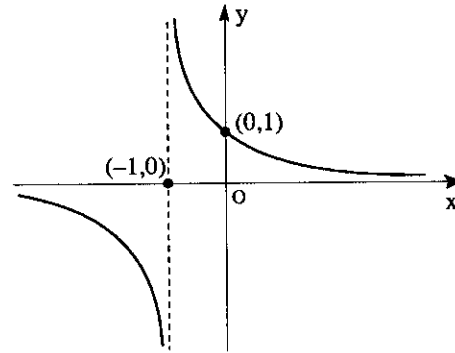

4

part marks	Unit	non-calc		calc		calc neut		Content Reference :		1.3
		C	A/B	C	A/B	C	A/B	Main	Additional	
4	1.3	1	3					1.3.11		Source 1993 P1 qu.21

- ¹ show that $f'(x) < 0$
- ² $f(x) = (x+1)^{-1}$
- ³ $f'(x) = \frac{-1}{(x+1)^2}$
- ⁴ explaining that $(x+1)^2 > 0 \Rightarrow f'(x) < 0$

Find the equation of the tangent to the curve with equation $y = 5x^3 - 6x^2$ at the point where $x = 1$.

4

part	marks	Unit	non-calc		calc		calc neut		Content Reference :		1.3
			C	A/B	C	A/B	C	A/B	Main	Additional	
.	4	1.3	4						1.3.9	1.1.7	Source 1992 P1 qu.1

<ul style="list-style-type: none"> •¹ $y' = 15x^2 - 12x$ •² $y'(1) = 3$ •³ $y(1) = -1$ •⁴ $y - (-1) = 3(x - 1)$

In the diagram A is the point (7,0), B is (-3,-2) and C(-1,8).

The median CE and the altitude BD intersect at J.

(a) Find the equations of CE and BD.

(b) Find the co-ordinates of J.

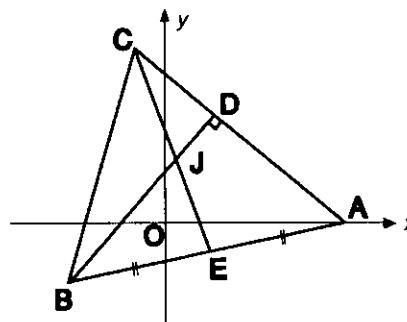

6

2

part	marks	Unit	non-calc		calc		calc neut		Content Reference :		1.1
			C	A/B	C	A/B	C	A/B	Main	Additional	
(a)	6	1.1	6						1.1.7	1.1.9, 1.1.1	Source
(b)	2	1.1	2						1.1.10		1992 P1 qu.2

<ul style="list-style-type: none"> •¹ $E = (2, -1)$ •² $m_{CE} = -3$ •³ $y - (-1) = -3(x - 2)$ or $y - 8 = -3(x - (-1))$ 	<ul style="list-style-type: none"> •⁴ $m_{AC} = -1$ •⁵ $m_{BD} = -1$ •⁶ $y - (-2) = 1(x - (-3))$ •⁷ strat: attempt to solve simultaneously •⁸ $J = (1, 2)$
--	--

Find k if $x - 2$ is a factor of $x^3 + kx^2 - 4x - 12$.

3

part marks	Unit	non-calc		calc		calc neut		Content Reference :		2.1
		C	A/B	C	A/B	C	A/B	Main	Additional	
3	2.1					3		2.1.1		Source 1992 P1 qu.3

<ul style="list-style-type: none"> •¹ $f(2) = 8 + 4k - 8 - 12$ •² $f(2) = 0$ •³ $k = 3$ 	<ul style="list-style-type: none"> •¹ correct use of division •² remainder = $4k - 12$ •³ $k = 3$
--	---

A curve for which $\frac{dy}{dx} = 3x^2 + 1$ passes through the point $(-1, 2)$.

Express y in terms of x .

4

part marks	Unit	non-calc		calc		calc neut		Content Reference :		2.2
		C	A/B	C	A/B	C	A/B	Main	Additional	
4	2.2	4						2.2.8		Source 1992 P1 qu.4

<ul style="list-style-type: none"> •¹ $\int (3x^2 + 1) dx$ •² $x^3 + x$ •³ $+c$ •⁴ $y = x^3 + x + 4$
--

Find, correct to one decimal place, the value of x between 180 and 270 which satisfies the equation $3\cos(2x - 40)^\circ - 1 = 0$.

5

part marks	Unit	non-calc		calc		calc neut		Content Reference :		2.3
		C	A/B	C	A/B	C	A/B	Main	Additional	
5	2.3			5				2.3.1		Source 1992 P1 qu.5

- ¹ $\cos(2x - 40)^\circ = \frac{1}{3}$
- ² $\cos^{-1} \frac{1}{3} = 70.53$
- ³ $2x - 40 = 70.5 \quad 289.5 \quad 430.5 \quad 649.5$
- ⁴ $x = 55.25 \quad 164.75 \quad 235.25 \quad 344.75$
- ⁵ $x = 235.25$

On a suitable set of real numbers, functions f and g are defined by

$$f(x) = \frac{1}{x+2} \quad \text{and} \quad g(x) = \frac{1}{x} - 2.$$

Find $f(g(x))$ in its simplest form.

3

part marks	Unit	non-calc		calc		calc neut		Content Reference :		1.2
		C	A/B	C	A/B	C	A/B	Main	Additional	
3	1.2	3						1.2.6		Source 1992 P1 qu.6

- ¹ $f\left(\frac{1}{x} - 2\right)$
- ² $\frac{1}{\frac{1}{x} - 2 + 2}$
- ³ x

(a) Express $\sin x^\circ - 3 \cos x^\circ$ in the form $k \sin(x - a)^\circ$ where $k > 0$ and $0 \leq a < 360$. Find the values of k and a .

4

(b) Find the maximum value of $5 + \sin x^\circ - 3 \cos x^\circ$ and state a value of x for which this maximum occurs.

2

part	marks	Unit	non-calc		calc		calc neut		Content Reference :		3.4
			C	A/B	C	A/B	C	A/B	Main	Additional	
(a)	4	3.4			4				3.4.1		Source
(b)	2	3.4			1	1			3.4.3		1992 P1 qu.7

- ¹ $k \cos a = 1$
- ² $k \sin a = 3$
- ³ $k = \sqrt{10}$
- ⁴ $a = 71.6$
- ⁵ maximum = $5 + \sqrt{10}$
- ⁶ angle = 161.6°

Evaluate $\int_1^9 \frac{x+1}{\sqrt{x}} dx$

5

part	marks	Unit	non-calc		calc		calc neut		Content Reference :		2.2
			C	A/B	C	A/B	C	A/B	Main	Additional	
.	5	2.2	5						2.2.5		Source
											1992 P1 qu.8

- ¹ $x^{\frac{1}{2}}$
- ² $x^{-\frac{1}{2}}$
- ³ $\frac{2}{3}x^{\frac{3}{2}}$
- ⁴ $2x^{\frac{1}{2}}$
- ⁵ $21\frac{1}{3}$

An ancient Stone Circle has a processional pathway from the Heelstone to the centre of the Stone Circle. In the picture above, the Heelstone is on the left and the dotted line represents the processional pathway.

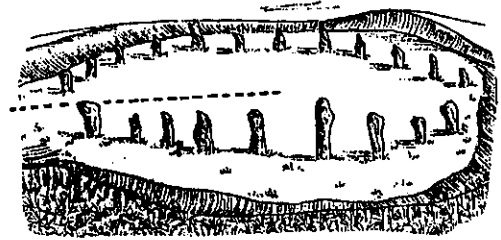

With suitable axes and using the heelstone as the origin, the equation of the Stone Circle is

$$x^2 + y^2 - 8x - 6y + 21 = 0.$$

Given that 1 unit represents 15metres, calculate the distance in metres from the Heelstone to the nearest point on the edge of the Circle.

5

part	marks	Unit	non-calc		calc		calc neut		Content Reference :		2.4
			C	A/B	C	A/B	C	A/B	Main	Additional	
.	5	2.4					5		2.4.2	1.1.2, 0.1	Source 1992 P1 qu.9

<ul style="list-style-type: none"> •¹ strat: e.g. origin to centre – radius •² centre = (4,3) •³ radius = 2 units •⁴ origin to centre = 5 units •⁵ 45m
--

The sketch shows the graph of $y = f(x)$ for $-2 \leq x \leq 4$.

The function $g(x)$ has the line $x = 4$ as an axis of symmetry and $g(x) = f(x)$ for $-2 \leq x \leq 4$.

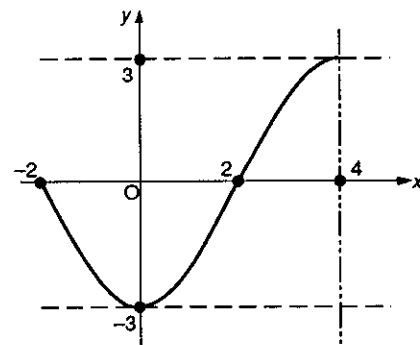

On separate sketches indicate

(a) $y = g(x)$ for $-2 \leq x \leq 10$

(b) $y = -2g(x)$ for $0 \leq x \leq 8$

2

2

part	marks	Unit	non-calc		calc		calc neut		Content Reference :		1.2
			C	A/B	C	A/B	C	A/B	Main	Additional	
(a)	2	1.2					2		1.2.4		Source
(b)	2	1.2					2		1.2.4		1992 P1 qu.10

<ul style="list-style-type: none"> •¹ for any two from list •² for the other two - correct shape and range - zeros at 6 and 10 - minimum at (8, -3) - annotation 		<ul style="list-style-type: none"> •³ for any two from list •⁴ for the other two - correct shape and range - zeros at 2 and 6 - extremes at (0,6), (8,6), (4,-6) - annotation 	
--	--	---	--

Differentiate $2x^{\frac{3}{2}} + \sin^2 x$ with respect to x .

4

part marks	Unit	non-calc		calc		calc neut		Content Reference :		3.2
		C	A/B	C	A/B	C	A/B	Main	Additional	
4	3.2	1	3					3.2.2		Source 1992 P1 qu.11

- ¹ $3x^{\frac{1}{2}}$
- ² $(\sin x)^2$ stated or implied by •³
- ³ $2 \sin x$
- ⁴ $\times \cos x$

An incomplete sketch (not drawn to scale) of the graph of $\log_{10}(x+a)$ is shown. Find the value of a .

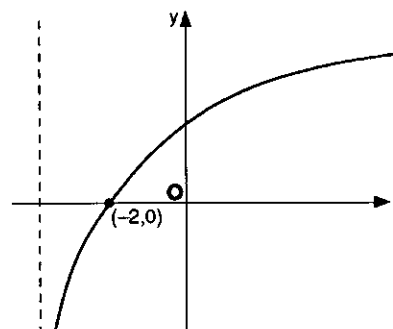

2

part marks	Unit	non-calc		calc		calc neut		Content Reference :		1.2
		C	A/B	C	A/B	C	A/B	Main	Additional	
2	1.2						2	1.2.3		Source 1992 P1 qu.12

- ¹ $\log_{10}(-2+a) = 0$
- ² 3

The diagram shows a kite OABC.
 A is the point (4,0) and B is the point (4,3).
 Calculate the gradient of OC correct to two decimal places.

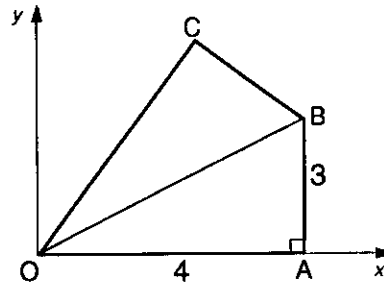

3

part	marks	Unit	non-calc		calc		calc neut		Content Reference :		1.1
			C	A/B	C	A/B	C	A/B	Main	Additional	
.	3	1.1			3				1.1.3		Source 1992 P1 qu.13

- ¹ strat: i.e. try to evaluate $\hat{C}OA$
- ² $\hat{A}OB = 36.9^\circ$
- ³ $\tan 73.7^\circ = 3.428$
- ⁴ $\times \cos x$

(a) Evaluate $\int_0^{\frac{\pi}{2}} \cos 2x \, dx$.

3

(b) Draw a sketch and explain your answer.

2

part	marks	Unit	non-calc		calc		calc neut		Content Reference :		3.2
			C	A/B	C	A/B	C	A/B	Main	Additional	
(a)	3	3.2		3					3.2.4		Source
(b)	2	1.2	1	1					1.2.3	2.2.6	1992 P1 qu.14

- ¹ $\frac{1}{2}$
- ² $\sin 2x$
- ³ 0
- ⁴ diagram
- ⁵ +ve and -ve cancel out

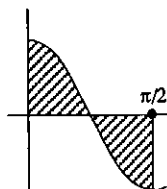

An aircraft flying at a constant speed on a straight flight path takes 2 minutes to fly from A to B and 1 minute to fly from B to C. Relative to a suitable set of axes, A is the point $(-1, 3, 4)$ and B is the point $(3, 1, -2)$. Find the co-ordinates of the point C.

3

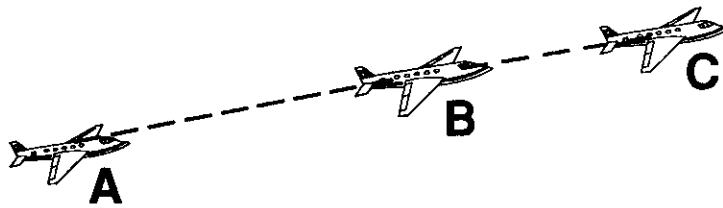

part	marks	Unit	non-calc		calc		calc neut		Content Reference :		3.1
			C	A/B	C	A/B	C	A/B	Main	Additional	
.	3	3.1					3		3.1.6		Source 1992 P1 qu.15

<ul style="list-style-type: none"> •¹ $\vec{AB} = \begin{pmatrix} 4 \\ -2 \\ -6 \end{pmatrix}$ •² $\vec{BC} = \vec{AB}$ •³ $(5, 0, -5)$
--

AB is a tangent at B to the circle with centre C and equation $(x-2)^2 + (y-2)^2 = 25$.
The point A has co-ordinates $(10, 8)$.
Find the area of triangle ABC.

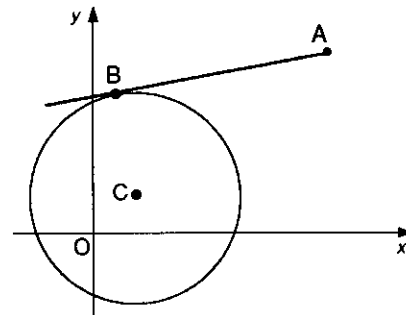

5

part	marks	Unit	non-calc		calc		calc neut		Content Reference :		2.4
			C	A/B	C	A/B	C	A/B	Main	Additional	
.	5	2.4					5		2.4.1	1.1.2, 0.1	Source 1992 P1 qu.16

<ul style="list-style-type: none"> •¹ strat: i.e find AC then AB •² centre = $(2, 2)$ and radius = 5 •³ $AC = 10$ •⁴ $AB = \sqrt{75}$ units •⁵ area = $\frac{25}{2}\sqrt{3}$ square units

Calculate the least positive integer value of k so that the graph of $y = kx^2 - 8x + k$ does not cut or touch the x -axis.

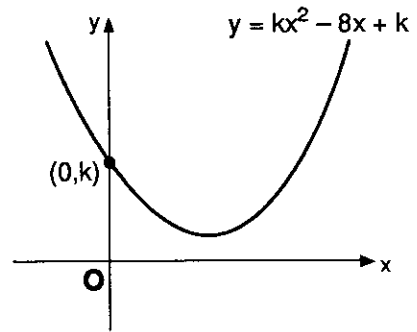

4

part marks	Unit	non-calc		calc		calc neut		Content Reference :		2.1
		C	A/B	C	A/B	C	A/B	Main	Additional	
4	2.1	1	3					2.1.7		Source 1992 P1 qu.17

<ul style="list-style-type: none"> •¹ strat: use discriminant •² $b^2 - 4ac < 0$ •³ $64 - 4k^2$ •⁴ $k = 5$
--

The diagram shows representatives of two vectors, a and b , inclined at an angle of 60° .

If $|a| = 2$ and $|b| = 3$, evaluate $a \cdot (a + b)$

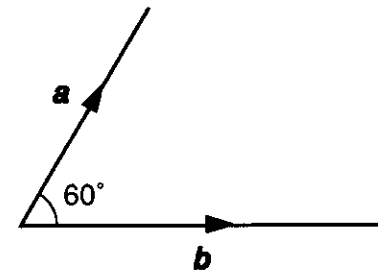

3

part marks	Unit	non-calc		calc		calc neut		Content Reference :		3.1
		C	A/B	C	A/B	C	A/B	Main	Additional	
3	3.1					3		3.1.9		Source 1992 P1 qu.18

<ul style="list-style-type: none"> •¹ $a \cdot a + a \cdot b$ •² $2 \times 3 \times \cos 60^\circ$ •³ 4

The line with equation $y = x$ is a tangent at the origin to the parabola with equation $y = f(x)$. The parabola has a maximum turning point at (a, b) . Sketch the graph of $y = f'(x)$.

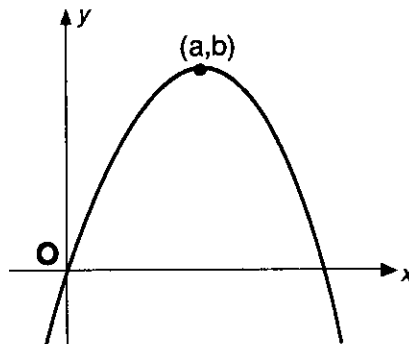

4

part	marks	Unit	non-calc		calc		calc neut		Content Reference :		1.3
			C	A/B	C	A/B	C	A/B	Main	Additional	
.	4	1.3					1	3	1.3.7	1.2.4	Source 1992 P1 qu.19

<ul style="list-style-type: none"> •¹ $f'(a) = 0$ •² m_{tgt} at $(0,0) = 1$ •³ $f'(0) = 1$ •⁴ for the sketch 	
---	--

Find the equation of the line through the point (3, -5) which is parallel to the line with equation $3x + 2y - 5 = 0$.

2

part marks	Unit	non-calc		calc		calc neut		Content Reference :		1.1
		C	A/B	C	A/B	C	A/B	Main	Additional	
2	1.1					2		1.1.7	1.1.8	Source 1991 P1 qu.1

<ul style="list-style-type: none"> •¹ $m = -\frac{3}{2}$ stated or implied by •² $y - (-5) = -\frac{3}{2}(x - 3)$

The points A and B have coordinates (a, a^2) and $(2b, 4b^2)$ respectively. Determine the gradient of AB in its simplest form.

2

part marks	Unit	non-calc		calc		calc neut		Content Reference :		1.1
		C	A/B	C	A/B	C	A/B	Main	Additional	
2	1.1	2						1.1.1	0.1	Source 1991 P1 qu.2

<ul style="list-style-type: none"> •¹ $m_{AB} = \frac{4b^2 - a^2}{2b - a}$ •² $m_{AB} = \frac{(2b + a)(2b - a)}{2b - a} = 2b + a$

Show that the vectors $a = 2i + 3j - k$ and $b = 3i - j + 3k$ are perpendicular.

3

part	marks	Unit	non-calc		calc		calc neut		Content Reference :		3.1
			C	A/B	C	A/B	C	A/B	Main	Additional	
.	3	3.1					3		3.1.8	3.1.1	Source 1991 P1 qu.3

<ul style="list-style-type: none"> •¹ strat: $a \cdot b = \dots\dots\dots$ •² $a \cdot b = 0 \Rightarrow$ perpendicularity explicitly stated •³ $\begin{pmatrix} 2 \\ 3 \\ -1 \end{pmatrix} \cdot \begin{pmatrix} 3 \\ -1 \\ 3 \end{pmatrix} = 6 - 3 - 3 = 0$
--

The diagram shows part of the graph of $y = ke^{0.5x}$.

- (a) Find the value of k .
 (b) The line with equation $x = 1$ intersects the graph at P.
 Find the coordinates of the point P.

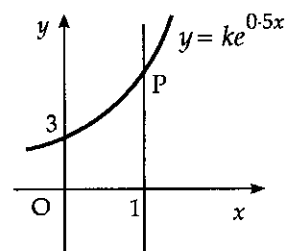

1
2

part	marks	Unit	non-calc		calc		calc neut		Content Reference :		3.3
			C	A/B	C	A/B	C	A/B	Main	Additional	
(a)	1	3.3			1				3.3.4		Source
(b)	2	3.3			2				3.3.4		1991 P1 qu.4

<ul style="list-style-type: none"> •¹ $3 = ke^0 \Rightarrow k = 3$ •² $y = 3e^{0.5}$ or equivalent •³ (1, 4.9)
--

Find the equation of the tangent to the curve $y = 3x^2 + 2$ at the point where $x = 1$.

4

part	marks	Unit	non-calc		calc		calc neut		Content Reference :		1.3
			C	A/B	C	A/B	C	A/B	Main	Additional	
.	4	1.3	4						1.3.9	1.1.7	Source 1991 P1 qu.5

<ul style="list-style-type: none"> •¹ strat: $\frac{dy}{dx} = \dots\dots$ •² $f'(1) = 6$ •³ $f(1) = 5$ •⁴ $y - 5 = 6(x - 1)$
--

When $f(x) = 2x^4 - x^3 + px^2 + qx + 12$ is divided by $(x - 2)$, the remainder is 114.

One factor of $f(x)$ is $(x - 2)$.

Find the values of p and q .

5

part	marks	Unit	non-calc		calc		calc neut		Content Reference :		2.1
			C	A/B	C	A/B	C	A/B	Main	Additional	
.	5	2.1					5		2.1.1		Source 1991 P1 qu.6

<ul style="list-style-type: none"> •¹ $f(2) = 114$ •² $f(-1) = 0$ •³ $4p + 2q = 78$ •⁴ $p - q = -15$ •⁵ $p = 8, q = 23$
--

- (a) Show that the points L(-5, 6, -5), M(7, -2, -1) and N(10, -4, 0) are collinear.
 (b) Find the ratio in which M divides LN.

4
1

part	marks	Unit	non-calc		calc		calc neut		Content Reference :		3.1
			C	A/B	C	A/B	C	A/B	Main	Additional	
(a)	4	3.1					4		3.1.7		Source
(b)	1	3.1					1		3.1.6		1991 P1 qu.7

<ul style="list-style-type: none"> •¹ $\vec{LM} = \begin{pmatrix} 12 \\ -8 \\ 4 \end{pmatrix}$ or equivalent combinations for (a) •² $\vec{MN} = \begin{pmatrix} 3 \\ -2 \\ 1 \end{pmatrix}$ 	<ul style="list-style-type: none"> •³ $\vec{LM} = 4\vec{MN}$ •⁴ vectors are parallel and have common point so L, M, N are collinear •⁵ 4:1
--	---

Find the equation of the tangent at the point (3, 1) on the circle $x^2 + y^2 - 4x + 6y - 4 = 0$.

5

part	marks	Unit	non-calc		calc		calc neut		Content Reference :		2.4
			C	A/B	C	A/B	C	A/B	Main	Additional	
.	5	2.4					5		2.4.4		Source
											1991 P1 qu.8

<ul style="list-style-type: none"> •¹ strat: use centre and tgt \perp radius •² centre = (2, -3) •³ $m_{radius} = 4$ •⁴ $m_{tgt} = -\frac{1}{4}$ •⁵ $y - 1 = -\frac{1}{4}(x - 3)$

The diagram shows the graph of $y = f(x)$, where $-2 \leq x \leq 3$.

On separate diagrams, sketch the graphs of

(a) $y = -f(x)$;

(b) $y = f'(x)$.

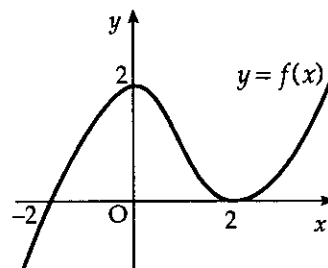

2
3

part	marks	Unit	non-calc		calc		calc neut		Content Reference :		1.2
			C	A/B	C	A/B	C	A/B	Main	Additional	
(a)	2	1.2	2						1.2.4		Source
(b)	3	1.2	3						1.2.4		1991 P1 qu.9

<ul style="list-style-type: none"> •¹ for correct shape •² for annotation •³ $f'(0) = 0$ •⁴ $f'(2) = 0$ •⁵ for correct shape 		
--	--	--

A curve with equation $y = f(x)$ passes through the point $(2, -1)$ and is such that $f'(x) = 4x^3 - 1$.
Express $f(x)$ in terms of x .

5

part	marks	Unit	non-calc		calc		calc neut		Content Reference :		2.2
			C	A/B	C	A/B	C	A/B	Main	Additional	
.	5	2.2	5						2.2.8		Source
											1991 P1 qu.10

<ul style="list-style-type: none"> •¹ $\int (4x^3 - 1) dx = \dots$ •² $x^4 - x$ •³ $+c$ •⁴ $f(2) = 14 + c$ •⁵ $c = -15$
--

On the day of his thirteenth birthday, a boy is given a sum of money to invest and instructions not to withdraw any money until after his eighteenth birthday. The money is invested and compound interest of 9% per annum is added each following birthday. By what percentage will the investment have increased when he withdraws his money just after his eighteenth birthday?

3

part marks	Unit	non-calc		calc		calc neut		Content Reference :		1.4
		C	A/B	C	A/B	C	A/B	Main	Additional	
3	1.4			3				1.4.3		Source 1991 P1 qu.11

<ul style="list-style-type: none"> •¹ 1.09 •² for using $(...)^5$ •³ approx. 54%

Given that $\sin A = \frac{3}{4}$, where $0 < A < \frac{\pi}{2}$, find the exact value of $\sin 2A$.

3

part marks	Unit	non-calc		calc		calc neut		Content Reference :		2.3
		C	A/B	C	A/B	C	A/B	Main	Additional	
3	2.3	3						2.3.3		Source 1991 P1 qu.12

<ul style="list-style-type: none"> •¹ strat for cos: eg $\cos^2 = 1 - \sin^2$ •² $\cos A = \frac{\sqrt{7}}{4}$ •³ $\sin 2A = \frac{3\sqrt{7}}{8}$
--

Given that $f(x) = 5(7 - 2x)^3$, find the value of $f'(4)$.

4

part	marks	Unit	non-calc		calc		calc neut		Content Reference :		3.2
			C	A/B	C	A/B	C	A/B	Main	Additional	
.	4	3.2		4					3.2.2		Source 1991 P1 qu.13

- ¹ $(7 - 2x)^2$
- ² $\times 15$
- ³ $\times -2$
- ⁴ -30

The diagram shows a rough sketch of the curves $y = f(x)$, $y = g(x)$ and $y = h(x)$.

The coordinates are A(-4, 12), B(-2, 0), C(-1, -3), D(1, 3) E(2, 0) and F(4, 12).

State the range of values of x for which

- (a) $f(x) \leq g(x)$;
 (b) $h(x) < g(x) < f(x)$.

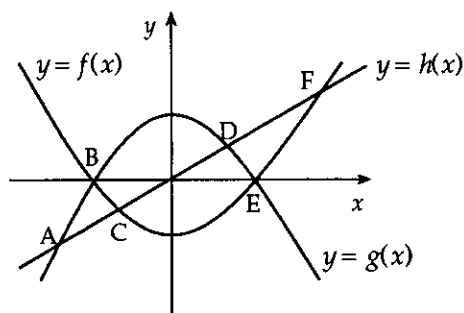

1
3

part	marks	Unit	non-calc		calc		calc neut		Content Reference :		1.2
			C	A/B	C	A/B	C	A/B	Main	Additional	
(a)	1	1.2					1		1.2.1		Source
(b)	3	1.2					3		1.2.1		1991 P1 qu.14

- ¹ $-2 \leq x \leq 2$
- ² $-4 \dots\dots$
- ³ $\dots\dots 2$
- ⁴ $-4 < x < 2$

- (a) Express $7 - 2x - x^2$ in the form $a - (x + b)^2$ and write down the values of a and b. 2
- (b) State the maximum value of $7 - 2x - x^2$ and justify your answer. 2

part	marks	Unit	non-calc		calc		calc neut		Content Reference :		1.2
			C	A/B	C	A/B	C	A/B	Main	Additional	
(a)	2	1.2		2					1.2.8		Source 1991 P1 qu.15
(b)	2	1.2		2				1.2.9			

- ¹ $a = 8$
- ² $b = 1$
- ³ $\text{max} = 8$
- ⁴ $(x+1)^2 \geq 0$, smallest value is zero

- (a) Find the value $\int_1^2 (4 - x^2) dx$. 3
- (b) Sketch a graph and shade the area represented by the integral in (a). 2

part	marks	Unit	non-calc		calc		calc neut		Content Reference :		2.2
			C	A/B	C	A/B	C	A/B	Main	Additional	
(a)	3	2.2	3						2.2.5		Source 1991 P1 qu.16
(b)	2	2.2	2					2.2.6			

- ¹ $4x$
- ² $\frac{1}{3}x^3$
- ³ $1\frac{2}{3}$
- ⁴ for diagram 1 as shown
- ⁵ shading 1 to 2

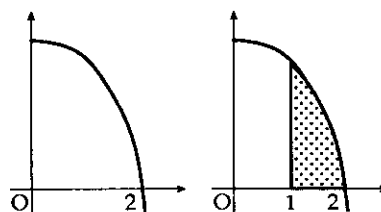

The diagram shows a right-angled isosceles triangle whose sides are represented by the vectors a , b and c .
 The two equal sides have length 2 units.
 Find the value of $b \cdot (a + b + c)$

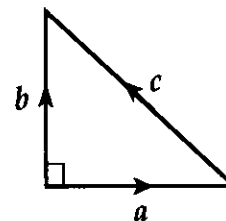

5

part marks	Unit	non-calc		calc		calc neut		Content Reference :		3.1
		C	A/B	C	A/B	C	A/B	Main	Additional	
5	3.1					5		3.1.9	3.1.1	Source 1991 P1 qu.17

<ul style="list-style-type: none"> •¹ $b \cdot a + b \cdot b + b \cdot c$ •² $b \cdot a = 0$ •³ $b \cdot b = 4$ •⁴ $c = 2\sqrt{2}$ •⁵ $b \cdot c = 4$
--

Given that k is a real number, show that the roots of the equation $kx^2 + 3x + 3 = k$ are always real numbers.

5

part marks	Unit	non-calc		calc		calc neut		Content Reference :		2.1
		C	A/B	C	A/B	C	A/B	Main	Additional	
5	2.1	1	4					2.1.6		Source 1991 P1 qu.18

<ul style="list-style-type: none"> •¹ for realising "$b^2 - 4ac \geq 0$" •² $kx^2 + 3x + (3 - k) = 0$ •³ $\Delta = 3^2 - 4k(3 - k)$ •⁴ $\Delta = (2k - 3)^2$ •⁵ for stating $(2k - 3)^2 \geq 0$ for all real k
--

The diagram illustrates three functions f , g and h . The functions are defined by $f(x) = 2x + 5$ and $g(x) = x^2 - 3$.

The function h is such that whenever $f(p) = q$ and $g(q) = r$ then $h(p) = r$.

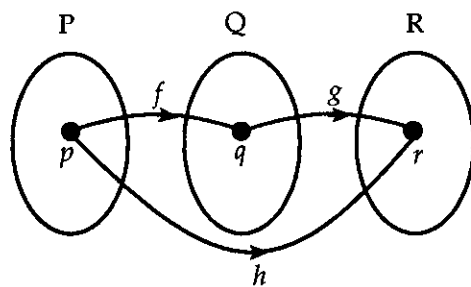

2
2

- (a) If $q = 7$, find the values of p and r .
 (b) Find a formula for $h(x)$, in terms of x .

part	marks	Unit	non-calc		calc		calc neut		Content Reference :		1.2
			C	A/B	C	A/B	C	A/B	Main	Additional	
(a)	2	1.2	2						1.2.6		Source
(b)	2	1.2		2					1.2.6		1991 P1 qu.19

- ¹ $p = 1$
- ² $r = 46$
- ³ $h(x) = g(f(x))$
- ⁴ $h(x) = (2x + 5)^2 - 3$

The diagram shows two curves with equations $y = \cos 2x^\circ$ and $y = 1 + \sin x^\circ$ where $0 \leq x \leq 360$.

Find the x -coordinate of the point of intersection at A.

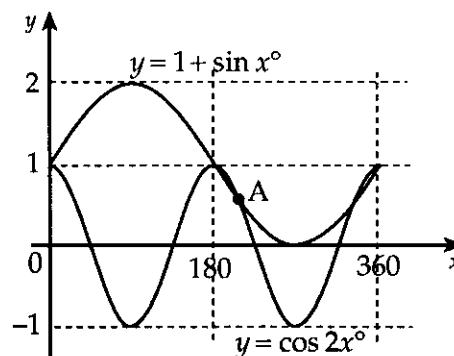

4

part	marks	Unit	non-calc		calc		calc neut		Content Reference :		2.3
			C	A/B	C	A/B	C	A/B	Main	Additional	
.	4	2.3	1	3					2.3.5		Source
											1991 P1 qu.20

- ¹ $\cos 2x^\circ = 1 + \sin x^\circ$
- ² $2 \sin^2 x^\circ + \sin x^\circ = 0$
- ³ $\sin x^\circ = 0$ or $-\frac{1}{2}$
- ⁴ $x = 210$

Find p if $(x + 3)$ is a factor of $x^3 - x^2 + px + 15$

3

part marks	Unit	non-calc		calc		calc neut		Content Reference :		2.1
		C	A/B	C	A/B	C	A/B	Main	Additional	
3	2.1					3		2.1.1		Source 1990 P1 qu.1

- ¹ strat: e.g. find $f(-3)$
- ² $f(-3) = 0$
- ³ $p = -7$

Find the equation of the tangent to the curve $y = 4x^3 - 2$ at the point where $x = -1$.

4

part marks	Unit	non-calc		calc		calc neut		Content Reference :		1.3
		C	A/B	C	A/B	C	A/B	Main	Additional	
4	1.3	4						1.3.9	1.1.7	Source 1990 P1 qu.2

- ¹ strat: $\frac{dy}{dx} = \dots\dots$
- ² $\frac{dy}{dx} = 12x^2$
- ³ $m = 12$
- ⁴ $y - (-6) = 12(x - (-1))$

A circle passes through A(-2, 3) and B(4, -1). Find the equation of the perpendicular to the chord AB.

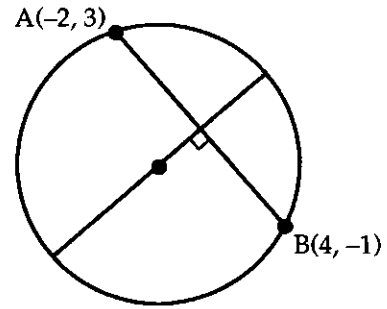

4

part	marks	Unit	non-calc		calc		calc neut		Content Reference :		1.1
			C	A/B	C	A/B	C	A/B	Main	Additional	
.	4	1.1					4		1.1.9	1.1.7	Source 1990 P1 qu.3

<ul style="list-style-type: none"> •¹ midpt = (1, 1) •² $m_{AB} = -\frac{2}{3}$ •³ $m_{diam} = \frac{3}{2}$ •⁴ $y - 1 = \frac{3}{2}(x - 1)$
--

Show that P(2, 2, 3), Q(4, 4, 1) and R(5, 5, 0) are collinear and find the ratio in which Q divides PR.

4

part	marks	Unit	non-calc		calc		calc neut		Content Reference :		3.1
			C	A/B	C	A/B	C	A/B	Main	Additional	
.	4	3.1					4		3.1.7	3.1.6	Source 1990 P1 qu.4

<ul style="list-style-type: none"> •¹ $\vec{PQ} = \begin{pmatrix} 2 \\ 2 \\ -2 \end{pmatrix}$ •² $\vec{QR} = \begin{pmatrix} 1 \\ 1 \\ -1 \end{pmatrix} = \frac{1}{2}\vec{PQ}$ 	 or equivalent 	<ul style="list-style-type: none"> •³ vectors parallel and have pt in common so pts collinear •⁴ $PQ:QR = 2:1$
--	------------------------------------	---

A cuboid crystal is placed relative to the coordinate axes as shown.

(a) Write down \vec{BC} in component form.

(b) Calculate $|\vec{BC}|$.

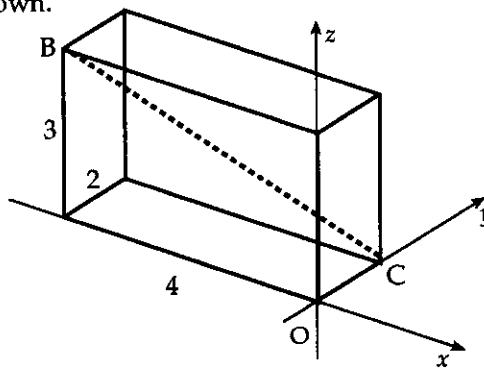

2

part	marks	Unit	non-calc		calc		calc neut		Content Reference :		3.1
			C	A/B	C	A/B	C	A/B	Main	Additional	
(a)	1	3.1					1		3.1.1		Source
(b)	1	3.1					1		3.1.3		1990 P1 qu.5

•¹ $\vec{BC} = \begin{pmatrix} 4 \\ 2 \\ -3 \end{pmatrix}$

•² $\sqrt{29}$

Evaluate $\int_1^2 (3x^2 + 4) dx$ and draw a sketch to illustrate the area represented by this integral.

5

part	marks	Unit	non-calc		calc		calc neut		Content Reference :		2.2
			C	A/B	C	A/B	C	A/B	Main	Additional	
.	5	2.2	5						2.2.5	2.2.6	Source
											1990 P1 qu.6

- ¹ x^3
- ² $4x$
- ³ 11
- ⁴ sketch of parabola with min above origin
- ⁵ shade from 1 to 2

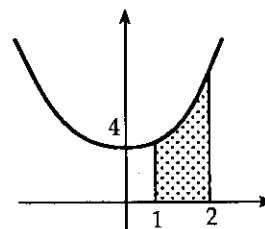

A bakery firm makes gingerbread men each 14cm high with a circular "head" and "body".

The equation of the "body" is $x^2 + y^2 - 10x - 12y + 45 = 0$ and the line of centres is parallel to the y -axis. Find the equation of the "head".

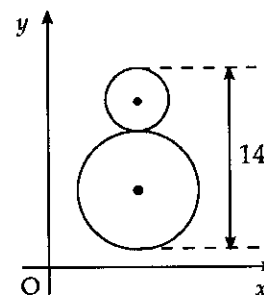

5

part marks	Unit	non-calc		calc		calc neut		Content Reference :		2.4
		C	A/B	C	A/B	C	A/B	Main	Additional	
5	2.4					5		2.4.2	2.4.3	Source 1990 P1 qu.7

<ul style="list-style-type: none"> •¹ centre of body = (5,6) •² radius of body = 4 •³ radius of head = 3 •⁴ centre of head = (5,13) •⁵ $(x-5)^2 + (y-13)^2 = 9$
--

For all points on the curve $y = f(x)$, $f'(x) = 1 - 2x$.

If the curve passes through the point (2, 1), find the equation of the curve.

4

part marks	Unit	non-calc		calc		calc neut		Content Reference :		2.2
		C	A/B	C	A/B	C	A/B	Main	Additional	
4	2.2	4						2.2.8		Source 1990 P1 qu.8

<ul style="list-style-type: none"> •¹ $\int (1 - 2x) dx = \dots\dots$ •² $x - x^2$ •³ $+c$ •⁴ $c = 3$

Given that $\cos D = \frac{2}{\sqrt{5}}$ and $0 < D < \frac{\pi}{2}$, find the exact values of $\sin D$ and $\cos 2D$.

3

part marks	Unit	non-calc		calc		calc neut		Content Reference :		2.3
		C	A/B	C	A/B	C	A/B	Main	Additional	
3	2.3	3						2.3.3		Source 1990 P1 qu.9

<ul style="list-style-type: none"> •¹ strat for exact value: e.g. $\sin^2 D = 1 - \cos^2 D$ •² $\sin D = \frac{1}{\sqrt{5}}$ •³ $\cos 2D = \frac{3}{5}$
--

The diagram shows the graph of a sine function from 0° to 90° .

- (a) State the equation of the graph.
 (b) The line with equation $y = -1.5$ intersects the curve at A and B.
 Find the coordinates of A and B.

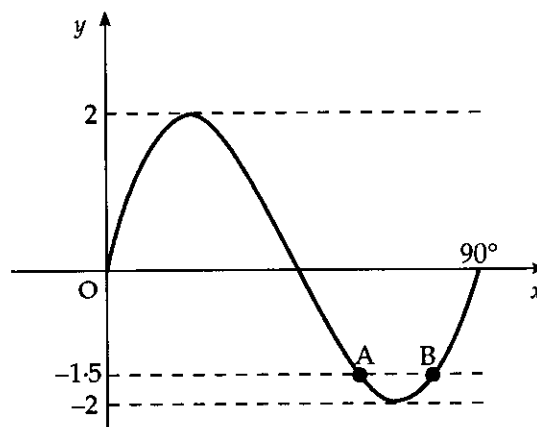

2

3

part marks	Unit	non-calc		calc		calc neut		Content Reference :		2.3
		C	A/B	C	A/B	C	A/B	Main	Additional	
(a)	2			2				1.2.2	1.2.7	Source
(b)	3			3				2.3.1		1990 P1 qu.10

<ul style="list-style-type: none"> •¹ $\sin 4x$ •² (trig function) $\times 2$ •³ $f(x) = -1.5$ •⁴ 57.1° •⁵ 77.9°

The diagram shows a sketch of a cubic function f with stationary points at $(0, 0)$ and $(2, 4)$. Sketch the graph of the derived function f' .

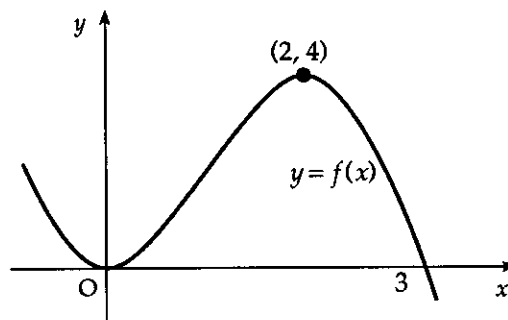

3

part marks	Unit	non-calc		calc		calc neut		Content Reference :		1.2
		C	A/B	C	A/B	C	A/B	Main	Additional	
3	1.2	2	1					1.2.4		Source 1990 P1 qu.11

- ¹ know that there are **exactly two zeros**
- ² **0 and 2**
- ³ any parabola with max t.p.

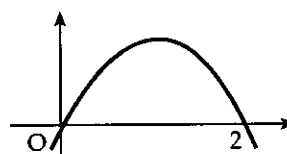

The vector $ai + bj + k$ is perpendicular to both the vectors $i - j + k$ and $-2i + j + k$. Find the values of a and b .

3

part marks	Unit	non-calc		calc		calc neut		Content Reference :		3.1
		C	A/B	C	A/B	C	A/B	Main	Additional	
3	3.1					3		3.1.8		Source 1990 P1 qu.12

- ¹ $\begin{pmatrix} a \\ b \\ 1 \end{pmatrix} \cdot \begin{pmatrix} 1 \\ -1 \\ 1 \end{pmatrix} = a - b + 1$ or $\begin{pmatrix} a \\ b \\ 1 \end{pmatrix} \cdot \begin{pmatrix} -2 \\ 1 \\ 1 \end{pmatrix} = -2a + b + 1$
- ² $a - b + 1 = 0$ or $-2a + b + 1 = 0$
- ³ $a = 2$ and $b = 3$

- (a) Find the coordinates of the points of intersection of the curves with equations $y = 2x^2$ and $y = 4 - 2x^2$. 2
- (b) Find the area completely enclosed between these two curves. 3

part	marks	Unit	non-calc		calc		calc neut		Content Reference :		2.2
			C	A/B	C	A/B	C	A/B	Main	Additional	
(a)	2	0.1	2						0.1		Source
(b)	3	2.2	3						2.2.7		1990 P1 qu.13

<ul style="list-style-type: none"> •¹ $2x^2 = 4x - 2x^2$ or $y = 4 - y$ •² $x = 1$ and $x = -1$ 	<ul style="list-style-type: none"> •³ $\int_{-1}^1 (4 - 2x^2 - 2x^2) dx$ •⁴ $4x - \frac{2}{3}x^3 - \frac{2}{3}x^3$ •⁵ $5\frac{1}{3}$
---	---

As shown in the diagram, a set of experimental results gives a straight line graph when $\log_{10} y$ is plotted against $\log_{10} x$. The straight line passes through (0, 1) and has a gradient of 2.

Express y in terms of x .

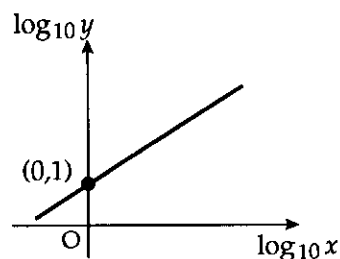

part	marks	Unit	non-calc		calc		calc neut		Content Reference :		3.3
			C	A/B	C	A/B	C	A/B	Main	Additional	
.	6	3.3					2	4	3.3.6	1.1.7	Source
											1990 P1 qu.14

<ul style="list-style-type: none"> •¹ use $y = mx + c$ •² $\log_{10} y = 2 \log_{10} x + 1$ •³ $\log_{10} y = 2 \log_{10} x + \log_{10} 10$ 	<ul style="list-style-type: none"> •⁴ $\log_{10} y = \log_{10} x^2 + 1$ •⁵ $\log_{10} y = \log_{10} 10x^2$ •⁶ $y = 10x^2$
--	--

Solve the equation $2\cos^2 x = \frac{1}{2}$, for $0 \leq x \leq \pi$.

3

part marks	Unit	non-calc		calc		calc neut		Content Reference :		2.3
		C	A/B	C	A/B	C	A/B	Main	Additional	
3	2.3	3						2.3.1	1.2.1	Source 1990 P1 qu.15

<ul style="list-style-type: none"> •¹ $\cos x = \pm \frac{1}{2}$ •² $x = \frac{\pi}{3}$ •³ $\frac{2\pi}{3}$
--

For what values of x is the function $f(x) = \frac{1}{3}x^3 - 2x^2 - 5x - 4$ increasing?

5

part marks	Unit	non-calc		calc		calc neut		Content Reference :		1.3
		C	A/B	C	A/B	C	A/B	Main	Additional	
5	1.3	2	3					1.3.11		Source 1990 P1 qu.16

<ul style="list-style-type: none"> •¹ $f'(x) = x^2 - 4x - 5$ •² use $f'(x) > 0$ •³ zeros at $x = 5$ and $x = -1$ •⁴ strat. e.g. for $-1 < x < 5$ test $x = 0$ •⁵ $x < -1, x > 5$
--

Make a copy of this graph of $y = \log_{10} x$.
 On your copy, sketch the graph of $y = \log_{10}(x - 2)$.

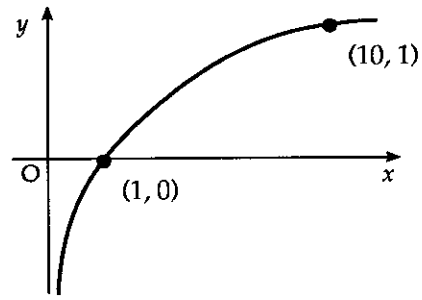

3

part marks	Unit	non-calc		calc		calc neut		Content Reference :		1.2
		C	A/B	C	A/B	C	A/B	Main	Additional	
3	1.2		3					1.2.4	1.2.5	Source 1990 P1 qu.17

- ¹ know $x = 2$ is asymptote
- ² graph passes thr' $(3, 0)$
- ³ graph passes thr' another marked point e.g. $(12, 1)$

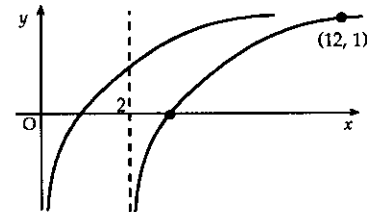

Show that the roots of the equation $(k - 2)x^2 - (3k - 2)x + 2k = 0$ are real.

4

part marks	Unit	non-calc		calc		calc neut		Content Reference :		2.1
		C	A/B	C	A/B	C	A/B	Main	Additional	
4	2.1					1	3	2.1.6		Source 1990 P1 qu.18

- ¹ use discriminant Δ
- ² $\Delta = (3k - 2)^2 - 8k(k - 2)$
- ³ $\Delta = k^2 + 4k + 4$
- ⁴ $(k + 2)^2 \geq 0$ so roots real

If $f(x) = \cos^2 x - \frac{2}{3x^2}$, find $f'(x)$.

4

part	marks	Unit	non-calc		calc		calc neut		Content Reference :		3.2
			C	A/B	C	A/B	C	A/B	Main	Additional	
.	4	3.2	2	2					3.2.2	1.3.4	Source 1990 P1 qu.19

- ¹ $-\frac{2}{3}x^{-2}$
- ² $2\cos x$
- ³ $\times(-\sin x)$
- ⁴ $\frac{4}{3}x^{-3}$

The right-angled triangle OAB with sides of length 3cm, 4cm and 5cm is placed with one vertex at the origin as shown in the diagram.

A circle centre C and diameter RO of length 13cm is drawn and passes through O and B.

What is the gradient of the line RO?

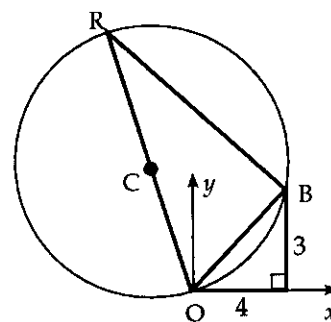

5

part	marks	Unit	non-calc		calc		calc neut		Content Reference :		1.1
			C	A/B	C	A/B	C	A/B	Main	Additional	
.	5	1.1			1	4			1.1.10	1.1.3	Source 1990 P1 qu.20

- ¹ *know to find $\tan \hat{R}\hat{O}X$*
- ² $\hat{R}\hat{B}O = 90^\circ$
- ³ $\hat{B}\hat{O}X = 36.9^\circ$
- ⁴ $\hat{R}\hat{O}B = 67.4^\circ$
- ⁵ $m_{RO} = -3.9$

The vertices of a triangle are P(-1, -1), Q(2, 1) and R(-6, 2). Find the equation of the altitude of triangle PQR, drawn from P.

3

part marks	Unit	non-calc		calc		calc neut		Content Reference :		1.1
		C	A/B	C	A/B	C	A/B	Main	Additional	
3	1.1					3		1.1.7	1.1.9	Source 1989 P1 qu.1

<ul style="list-style-type: none"> •¹ $m_{QR} = -\frac{1}{8}$ •² $m_{\perp} = 8$ •³ $y - (-1) = 8(x - (-1))$

Factorise fully $2x^3 + 5x^2 - 4x - 3$.

4

part marks	Unit	non-calc		calc		calc neut		Content Reference :		2.1
		C	A/B	C	A/B	C	A/B	Main	Additional	
4	2.1	4						2.1.3		Source 1989 P1 qu.2

<ul style="list-style-type: none"> •¹ <i>strat:</i> make 2 trial divisions or 2 trial evaluations •² first linear factor •³ quadratic factor •⁴ other linear factors $(x - 1)(2x + 1)(x + 3)$
--

The vectors p , q and r are defined as follows:

$$p = 3i - 3j + 2k, q = 4i - j + k, r = 4i - 2j + 3k.$$

(a) Find $2p - q + r$ in terms of i , j and k .

1

(b) Find the value of $|2p - q + r|$.

2

part	marks	Unit	non-calc		calc		calc neut		Content Reference :		3.1
			C	A/B	C	A/B	C	A/B	Main	Additional	
(a)	1	3.1					1		3.1.8		Source
(b)	2	3.1					2		3.1.1		1989 P1 qu.3

<ul style="list-style-type: none"> •¹ $6i - 7j + 6k$ •² $\sqrt{6^2 + (-7)^2 + 6^2}$ •³ 11

PQRS is a parallelogram with vertices P(1, 3, 3), Q(4, -2, -2) and R(3, 1, 1).

Find the coordinates of S.

3

part	marks	Unit	non-calc		calc		calc neut		Content Reference :		3.1
			C	A/B	C	A/B	C	A/B	Main	Additional	
.	3	3.1					3		3.1.4		Source
											1989 P1 qu.4

<ul style="list-style-type: none"> •¹ $\vec{QP} = \begin{pmatrix} -3 \\ 5 \\ 5 \end{pmatrix}$ •² $R = (3, 1, 1)$ and $\vec{RS} = \begin{pmatrix} -3 \\ 5 \\ 5 \end{pmatrix}$ stated or implied by •³ •³ $S = (0, 6, 6)$
--

Find $\int (2x^2 + 3) dx$.

3

part marks	Unit	non-calc		calc		calc neut		Content Reference :		2.2
		C	A/B	C	A/B	C	A/B	Main	Additional	
3	2.2	3						2.2.4		Source 1989 P1 qu.5

- ¹ $\frac{2}{3}x^3$
- ² $+3x$
- ³ $+c$

A(4, 4, 10), B(-2, -4, 12) and C(-8, 0, 10) are the vertices of a right-angled triangle.
Determine which angle of the triangle is the right angle.

3

part marks	Unit	non-calc		calc		calc neut		Content Reference :		3.1
		C	A/B	C	A/B	C	A/B	Main	Additional	
3	3.1					3		3.1.10		Source 1989 P1 qu.6

- ¹ $\vec{AB} = \begin{pmatrix} -6 \\ -8 \\ 2 \end{pmatrix}, \vec{BC} = \begin{pmatrix} -6 \\ 4 \\ -2 \end{pmatrix}, \vec{AC} = \begin{pmatrix} -12 \\ -4 \\ 0 \end{pmatrix}$
- ² $|\vec{AC}|$ is longest so $\vec{AB} \cdot \vec{CB} = -36 + 32 + 4 = 0$
- ³ $\hat{A}BC = 90^\circ$

Solve $2\sin 3x^\circ - 1 = 0$ for $0 \leq x \leq 180$.

4

part marks	Unit	non-calc		calc		calc neut		Content Reference :		2.3
		C	A/B	C	A/B	C	A/B	Main	Additional	
4	2.3	4						2.3.1	1.2.1	Source 1989 P1 qu.7

<ul style="list-style-type: none"> •¹ $\sin 3x^\circ = 0.5$ •² $3x = 30, 150$ •³ $x = 10, 50$ •⁴ solution is 10, 50, 130

Express $x^2 + 6x + 11$ in the form $(x+a)^2 + b$ and hence state the maximum value of $\frac{1}{x^2 + 6x + 11}$.

4

part marks	Unit	non-calc		calc		calc neut		Content Reference :		1.2
		C	A/B	C	A/B	C	A/B	Main	Additional	
4	1.2	4						1.2.8	1.2.9	Source 1989 P1 qu.8

<ul style="list-style-type: none"> •¹ $a = 3$ •² $b = 2$ •³ $\min(x^2 + 6x + 11) = 2$ •⁴ $\max\left(\frac{1}{x^2 + 6x + 11}\right) = \frac{1}{2}$

The sides of this equilateral triangle are 2 units long and represent the vectors a , b and c as shown.

5

Evaluate $a \cdot (a + b + c)$.

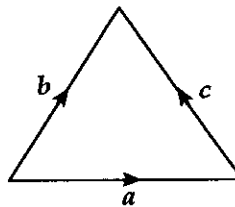

part marks	Unit	non-calc		calc		calc neut		Content Reference :		3.1
		C	A/B	C	A/B	C	A/B	Main	Additional	
5	3.1	1	4					3.1.9		Source 1989 P1 qu.9

<ul style="list-style-type: none"> •¹ $a \cdot a + a \cdot b + a \cdot c$ •² $a \cdot a = a a \cos 0$ •³ $a \cdot b = a b \cos 60$ •⁴ $a \cdot c = a c \cos 120$ •⁵ 4
--

Differentiate $\sin 2x + \frac{2}{\sqrt{x}}$ with respect to x .

4

part marks	Unit	non-calc		calc		calc neut		Content Reference :		3.2
		C	A/B	C	A/B	C	A/B	Main	Additional	
4	3.2	2	2					3.2.2	1.3.1	Source 1989 P1 qu.10

<ul style="list-style-type: none"> •¹ $2x^{-\frac{1}{2}}$ •² $\cos 2x$ •³ $\times 2$ •⁴ $-x^{-\frac{3}{2}}$

In the diagram, A and B have coordinates as shown.

Express $\sin \hat{AOB}$ in terms of a and b .

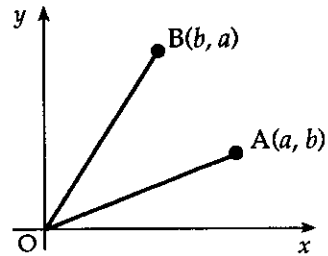

4

part marks	Unit	non-calc		calc		calc neut		Content Reference :		2.3
		C	A/B	C	A/B	C	A/B	Main	Additional	
4	2.3		4					2.3.2		Source 1989 P1 qu.11

<ul style="list-style-type: none"> •¹ $OA = OB = \sqrt{a^2 + b^2}$ •² $\sin \hat{AOB} = \sin(\hat{BOx} - \hat{AOx}) = \sin \hat{BOx} \cos \hat{AOx} - \cos \hat{BOx} \sin \hat{AOx}$ •³ $\frac{a}{\sqrt{a^2 + b^2}} \cdot \frac{a}{\sqrt{a^2 + b^2}} - \frac{b}{\sqrt{a^2 + b^2}} \cdot \frac{b}{\sqrt{a^2 + b^2}}$ •⁴ $\frac{a^2 - b^2}{a^2 + b^2}$
--

If $y = x^2 - x$, show that $\frac{dy}{dx} = 1 + \frac{2y}{x}$.

3

part marks	Unit	non-calc		calc		calc neut		Content Reference :		1.3
		C	A/B	C	A/B	C	A/B	Main	Additional	
3	1.3	1	2					1.3.4	0.1	Source 1989 P1 qu.12

<ul style="list-style-type: none"> •¹ $\frac{dy}{dx} = 2x - 1$ •² $RHS = 1 + \frac{2(x^2 - x)}{x}$ •³ $1 + 2(x - 1)$ and complete
--

Calculate, to the nearest degree, the angle between the x -axis and the tangent to the curve with equation $y = x^3 - 4x - 5$ at the point where $x = 2$.

4

part	marks	Unit	non-calc		calc		calc neut		Content Reference :		1.3
			C	A/B	C	A/B	C	A/B	Main	Additional	
.	4	1.3	4						1.3.9	1.1.3	Source 1989 P1 qu.13

- ¹ $\frac{dy}{dx} = 3x^2 - 4$
- ² $\frac{dy}{dx}_{x=2} = 8$
- ³ $\tan \theta = 8$
- ⁴ 83°

The diagram shows the graph of a cubic function with a maximum at (b, c) and a minimum at (d, e) . The tangent at $(0, a)$ is inclined at 45° to the x -axis.

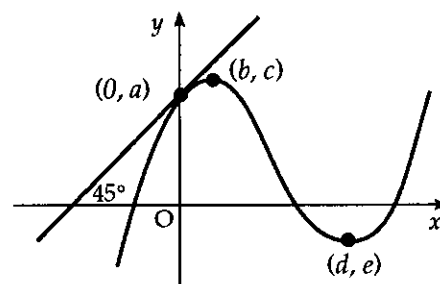

- (a) State the values of $f'(b)$, $f'(d)$ and $f'(0)$.
 (b) Sketch the graph of the the derived function f' .

2
2

part	marks	Unit	non-calc		calc		calc neut		Content Reference :		1.3
			C	A/B	C	A/B	C	A/B	Main	Additional	
(a)	2	1.3					2		1.3.9		Source
(b)	2	1.2					2		1.2.4		1989 P1 qu.14

- ¹ any one of $f'(b) = 0, f'(d) = 0, f'(0) = 1$
- ² remaining two answers
- ³ shape of graph
- ⁴ annotation

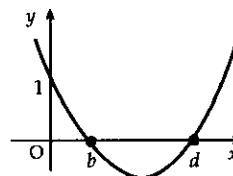

Find the values of t , where $0 < t < 2\pi$, for which $4 \cos\left(2t - \frac{\pi}{4}\right)$ has its maximum value.

4

part marks	Unit	non-calc		calc		calc neut		Content Reference :		2.3
		C	A/B	C	A/B	C	A/B	Main	Additional	
4	2.3	4						2.3.1		Source 1989 P1 qu.15

- ¹ $\cos\left(2t - \frac{\pi}{4}\right) = 1$
- ² $2t - \frac{\pi}{4} = 0$
- ³ $t = \frac{\pi}{8}$
- ⁴ $\frac{\pi}{8}, \frac{9\pi}{8}$

Find the value of $\int_1^2 \frac{u^2 + 2}{2u^2} du$.

5

part marks	Unit	non-calc		calc		calc neut		Content Reference :		2.2
		C	A/B	C	A/B	C	A/B	Main	Additional	
5	2.2	4	1					2.2.5		Source 1989 P1 qu.16

- ¹ *strat:* know to divide
- ² $\frac{1}{2} + u^{-2}$
- ³ $\frac{1}{2}u$
- ⁴ $-u^{-1}$
- ⁵ 1

The diagram shows a sketch of the graph of $y = \log_2 x$.
 Make a rough copy of the diagram.
 On your copy, sketch the graph of $y = \log_2 2x$.

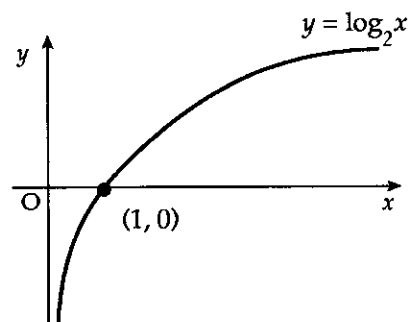

3

part marks	Unit	non-calc		calc		calc neut		Content Reference :		1.2
		C	A/B	C	A/B	C	A/B	Main	Additional	
3	1.2		3					1.2.5		Source 1989 P1 qu.17

- ¹ strat: $\log_2 2x = \log_2 2 + \log_2 x$
- ² translating graph upwards 1 unit
- ³ $(\frac{1}{2}, 0)$ clearly marked

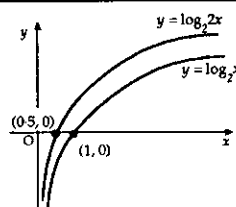

Find the possible values of k for which the line $x - y = k$ is a tangent to the circle $x^2 + y^2 = 18$.

5

part marks	Unit	non-calc		calc		calc neut		Content Reference :		2.4
		C	A/B	C	A/B	C	A/B	Main	Additional	
5	2.4					2	3	2.4.4		Source 1989 P1 qu.18

- ¹ $x^2 + (x - k)^2 = 18$
- ² $2x^2 - 2kx + k^2 - 18 = 0$
- ³ strat: " $b^2 - 4ac = 0$ "
- ⁴ $(-2k)^2 - 4 \cdot 2 \cdot (k^2 - 18)$
- ⁵ $k = \pm 6$

Functions f and g are defined by $f(x) = 2x + 3$ where $x \in \mathbf{R}$ and $g(x) = \frac{x^2 + 25}{x^2 - 25}$ where $x \in \mathbf{R}, x \neq 5$.

The function h is given by the formula $h(x) = g(f(x))$.

For which real values of x is the function h undefined?

4

part	marks	Unit	non-calc		calc		calc neut		Content Reference :		1.2
			C	A/B	C	A/B	C	A/B	Main	Additional	
.	4	1.2					2	2	1.2.6	1.2.1	Source 1989 P1 qu.19

- ¹ $g(2x + 3)$
- ² $\frac{(2x+3)^2 + 25}{(2x+3)^2 - 25}$
- ³ $(2x + 3)^2 - 25 = 0$
- ⁴ $x = 1, -4$

Medical researchers studying the growth of a strain of bacteria observe that the number of bacteria, present after t hours, is given by the formula $N(t) = 40e^{1.5t}$.

- (a) State the number of bacteria present at the start of the experiment.
- (b) How many minutes will the bacteria take to double in number?

1

4

part	marks	Unit	non-calc		calc		calc neut		Content Reference :		3.3
			C	A/B	C	A/B	C	A/B	Main	Additional	
(a)	1	3.3			1				3.3.4		Source
(b)	4	3.3			1	3			3.3.7		1989 P1 qu.20

- ¹ 40
- ² $40e^{1.5t} = 80$
- ³ $1.5t = \ln 2$
- ⁴ $t = 0.46$
- ⁵ 28 minutes

Two sound intensities P_1 and P_2 are said to differ by n decibels when $n = 10 \log_{10} \left(\frac{P_2}{P_1} \right)$

where P_1 and P_2 are measured in phons and $P_2 > P_1$.

Rustling leaves have a typical sound intensity of 30 phons.

If the sound intensity of a fire alarm siren is 6.5 decibels greater than rustling leaves, what is the sound intensity of the fire alarm system, measured in phons?

3

part marks	Unit	non-calc		calc		calc neut		Content Reference :		3.3
		C	A/B	C	A/B	C	A/B	Main	Additional	
3	3.3			1	2			3.3.4		Source 1989 P1 qu.21

- ¹ $6.5 = 10 \log_{10} \left(\frac{P}{30} \right)$
- ² $P = 30 \times 10^{0.65}$
- ³ 134 phons

- (a) Show that $x = 2$ is a root of the equation $2x^3 + x^2 - 13x + 6 = 0$.
 (b) Hence find the other roots.

1
3

part	marks	Unit	non-calc		calc		calc neut		Content Reference :		2.1
			C	A/B	C	A/B	C	A/B	Main	Additional	
(a)	1	2.1	1						2.1.1		Source 1999 P1 qu.1
(b)	3	2.1	3						2.1.2		

<p>•¹ $f(2) = 16 + 4 - 26 + 6 = 0$ <i>or</i> the appearance of a '0' at the end of the 3rd line in the table below</p>	<p>•² 2</p> <table border="1" style="margin-left: 20px;"> <tr><td>2</td><td>1</td><td>-13</td><td>6</td></tr> <tr><td>4</td><td>10</td><td>-6</td><td></td></tr> <tr><td>2</td><td>5</td><td>-3</td><td>0</td></tr> </table> <p>•³ $2x^2 + 5x - 3$ •⁴ $-3, \frac{1}{2}$</p>	2	1	-13	6	4	10	-6		2	5	-3	0
2	1	-13	6										
4	10	-6											
2	5	-3	0										

A and B are the points $(-3, -1)$ and $(5, 5)$.

Find the equation of

- (a) the line AB
 (b) the perpendicular bisector of AB.

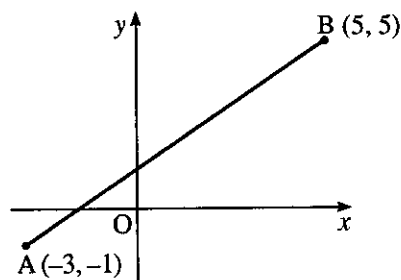

2
3

part	marks	Unit	non-calc		calc		calc neut		Content Reference :		1.1
			C	A/B	C	A/B	C	A/B	Main	Additional	
(a)	2	1.1					2		1.1.7		Source 1999 P1 qu.2
(b)	3	1.1					3		1.1.10		

<p>•¹ $m_{AB} = \frac{3}{4}$ •² $y - 5 = \frac{3}{4}(x - 5)$ or $y - (-1) = \frac{3}{4}(x - (-3))$</p>	<p>•³ $m_{\perp} = -\frac{4}{3}$ •⁴ midpoint = $(1, 2)$ •⁵ $y - 2 = -\frac{4}{3}(x - 1)$</p>
--	--

The line PQ has equation $y = 2x + 4$.

- (a) Find, without using calculus, the area of the shaded trapezium shown in the diagram.
- (b) Express the area of this trapezium as a definite integral.
- (c) Evaluate this integral.

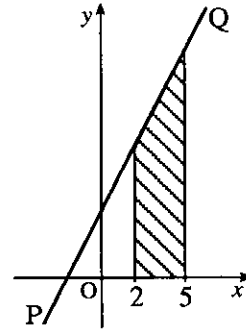

2
1
2

part	marks	Unit	non-calc		calc		calc neut		Content Reference :		2.5
			C	A/B	C	A/B	C	A/B	Main	Additional	
(a)	2	0.1	2						0.1		Source 1999 P1 qu.3
(b)	1	2.2	1						2.2.6		
(c)	2	2.2	2						2.2.5		

- ¹ evidence of e.g. triangle + rectangle
- ² area = 33
- ³ $\int_2^5 (2x+4) dx$
- ⁴ $x^2 + 4x$
- ⁵ $45 - 12 = 33$

Find the equation of the circle with centre $(-3, 4)$ and passing through the origin.

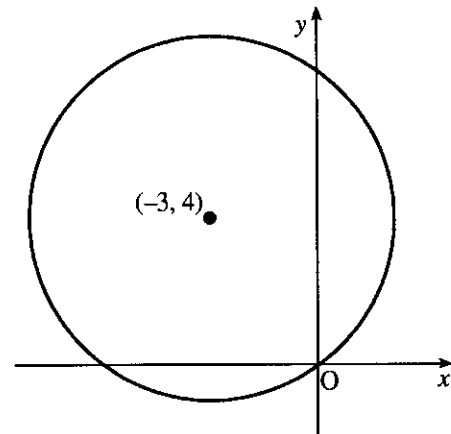

2

part	marks	Unit	non-calc		calc		calc neut		Content Reference :		2.4
			C	A/B	C	A/B	C	A/B	Main	Additional	
.	2	2.4					2		2.4.3		Source 1999 P1 qu.4

- ¹ $r^2 = 25$ stated or implied by •².
- ² $(x+3)^2 + (y-4)^2 = 25$

Given $f(x) = 3x^2(2x - 1)$ find $f'(-1)$.

3

part	marks	Unit	non-calc		calc		calc neut		Content Reference :		1.3
			C	A/B	C	A/B	C	A/B	Main	Additional	
.	3	1.3	3						1.3.4		Source 1999 P1 qu.5

- ¹ $6x^3 - 3x^2$
- ² $18x^2 - 6x$
- ³ 24

VABCD is a pyramid with rectangular base ABCD.

The vectors \vec{AB} , \vec{AD} and \vec{AV} are given by

$$\vec{AB} = 8i + 2j + 2k$$

$$\vec{AD} = -2i + 10j - 2k \quad \text{and}$$

$$\vec{AV} = i + 7j + 7k.$$

Express \vec{CV} in component form.

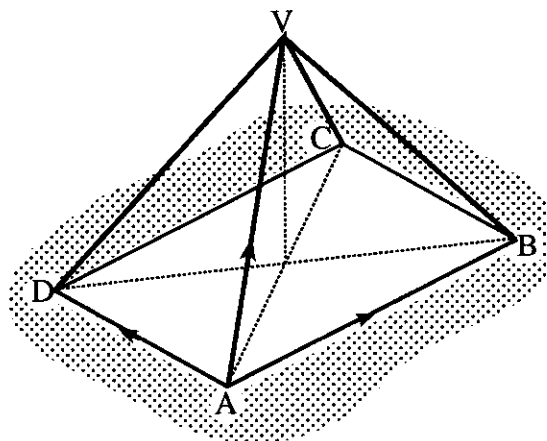

3

part	marks	Unit	non-calc		calc		calc neut		Content Reference :		3.1
			C	A/B	C	A/B	C	A/B	Main	Additional	
.	3	3.1					3		3.1.8		Source 1999 P1 qu.6

•¹ pathway for \vec{CV} : $\vec{CV} = \vec{CA} + \vec{AV}$

•² e.g. $\vec{CB} = 2i - 10j + 2k$

or $\vec{BA} = -8i - 2j - 2k$

or $\vec{AC} = 6i + 12j$

•³ $\begin{pmatrix} -5 \\ -5 \\ 7 \end{pmatrix}$

The line AB makes an angle of $\frac{\pi}{3}$ radians with the y -axis, as shown in the diagram. Find the exact value of the gradient of AB.

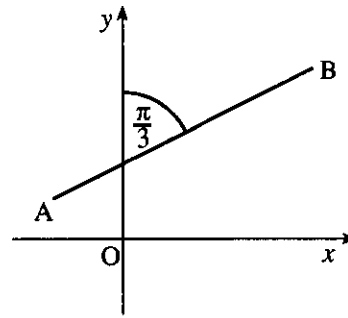

2

part	marks	Unit	non-calc		calc		calc neut		Content Reference :		1.1
			C	A/B	C	A/B	C	A/B	Main	Additional	
.	2	1.1						2	1.1.7		Source 1999 P1 qu.7

- ¹ "correct angle" = $\frac{\pi}{2} - \frac{\pi}{3}$
- ² $\frac{1}{\sqrt{3}}$

- (i) Write down the condition for the equation $ax^2 + bx + c = 0$ to have no real roots. 1
- (ii) Hence or otherwise show that the equation $x(x+1) = 3x - 2$ has no real roots. 2

part	marks	Unit	non-calc		calc		calc neut		Content Reference :		2.1
			C	A/B	C	A/B	C	A/B	Main	Additional	
(i)	1	2.1					1		2.1.6		Source 1999 P1 qu.8
(ii)	2	2.1					2		2.1.6		

- ¹ $b^2 - 4ac = 0$
- ² $x^2 + 6x + 9 = 0$
- ³ $b^2 - 4ac = 36 - 36 = 0$ OR •³ $(x+3)(x+3) = 0$ so roots are $-3, -3$

The point $P(-1, 7)$ lies on the curve with equation $y = 5x^2 + 2$. Find the equation of the tangent to the curve at P.

4

part	marks	Unit	non-calc		calc		calc neut		Content Reference :		1.3
			C	A/B	C	A/B	C	A/B	Main	Additional	
.	4	1.3	4						1.3.9	1.1.7	Source 1999 P1 qu.9

<ul style="list-style-type: none"> •¹ $\frac{dy}{dx} = \dots\dots$ •² $10x$ •³ -10 •⁴ $y - 7 = -10(x - (-1))$

Part of the graph of $y = f(x)$ is shown in the diagram.

On separate diagrams sketch the graphs of

(a) $y = f(x+1)$

(b) $y = -2f(x)$.

Indicate on each graph the images of O, A, B, C and D.

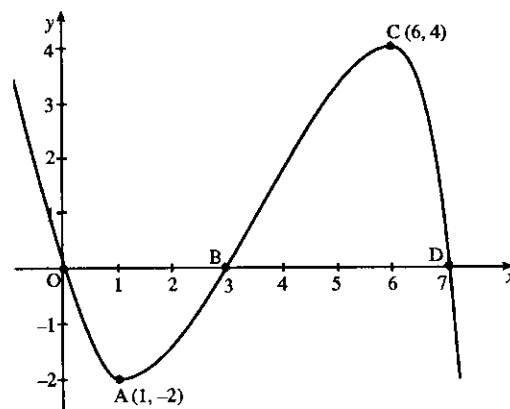

1

part	marks	Unit	non-calc		calc		calc neut		Content Reference :		1.2
			C	A/B	C	A/B	C	A/B	Main	Additional	
(a)	2	1.2	2						1.2.4		Source
(b)	3	1.2	1	2					1.2.4		1999 P1 qu.10

<ul style="list-style-type: none"> •¹ translation of $\begin{pmatrix} -1 \\ 0 \end{pmatrix}$ •² positions of images of A, B, C, D, O clear from the sketch 		<ul style="list-style-type: none"> •³ reflect in x - axis •⁴ double y - coordinates •⁵ positions of images of A, B, C, D, O clear from the sketch 	
---	--	---	--

The graph of $y = g(x)$ passes through the point (1,2).

If $\frac{dy}{dx} = x^3 + \frac{1}{x^2} - \frac{1}{4}$, express y in terms of x .

4

part marks	Unit	non-calc		calc		calc neut		Content Reference :		2.2
		C	A/B	C	A/B	C	A/B	Main	Additional	
4	2.2	4						2.2.8		Source 1999 P1 qu.11

- ¹ x^{-2} stated or implied by •² or •³
- ² $y = \int (x^3 + x^{-2} - \frac{1}{4})dx$ or the appearance of any term of $\frac{1}{4}x^4 - \frac{1}{4}x - x^{-1}$
- ³ the remaining two terms
- ⁴ $c = 3$

Using triangle PQR, as shown, find the exact value of $\cos 2x$.

3

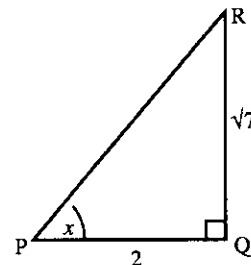

part marks	Unit	non-calc		calc		calc neut		Content Reference :		2.3
		C	A/B	C	A/B	C	A/B	Main	Additional	
3	2.3	3						2.3.3		Source 1999 P1 qu.12

- ¹ $\cos x = \frac{2}{\sqrt{11}}$ or $\sin x = \frac{\sqrt{7}}{\sqrt{11}}$
- ² $\cos 2x = 2 \times \left(\frac{2}{\sqrt{11}}\right)^2 - 1$
- ³ $-\frac{3}{11}$

- (a) Show that $f(x) = 2x^2 - 4x + 5$ can be written in the form $f(x) = a(x + b)^2 + c$. 3
- (b) Hence write down the coordinates of the stationary point of $y = f(x)$ and state its nature. 2

part	marks	Unit	non-calc		calc		calc neut		Content Reference :		1.2
			C	A/B	C	A/B	C	A/B	Main	Additional	
(a)	3	1.2	3						1.2.8		Source
(b)	2	1.2	2						1.2.9		1999 P1 qu.13

<ul style="list-style-type: none"> •¹ $2(x^2 - 2x) + 5$ stated or implied by •³ •² $2(x - 1)^2 + \dots$ stated or implied by •³ •³ $2(x - 1)^2 + 3$ •⁴ stationary pt at (1, 3) •⁵ stationary pt is minimum

The diagram shows part of the graph of $y = a \sin 3x^\circ$ and the line with equation $y = \frac{2}{3}a$. Find the x -coordinates of A and B.

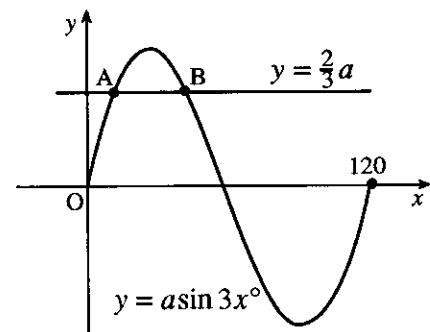

4

part	marks	Unit	non-calc		calc		calc neut		Content Reference :		2.3
			C	A/B	C	A/B	C	A/B	Main	Additional	
.	4	2.3	4						2.3.1		Source
											1999 P1 qu.14

<ul style="list-style-type: none"> •¹ $a \sin 3x = \frac{2}{3}a$ stated or implied by •² •² $\sin 3x = \frac{2}{3}$ •³ $3x = 41.8, 138.2$ (138.2 stated or implied by 46.1 in •⁴) •⁴ 13.9, 46.1
--

The diagram shows part of the graph of $y = \log_b(x+a)$.
Determine the values of a and b .

3

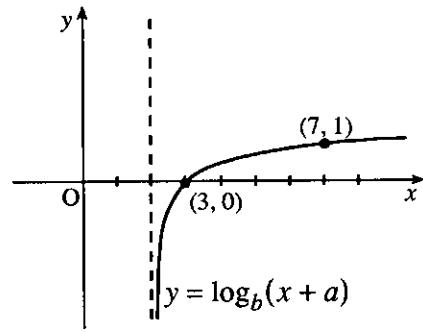

part marks	Unit	non-calc		calc		calc neut		Content Reference :		3.3
		C	A/B	C	A/B	C	A/B	Main	Additional	
3	3.3						3	3.3.1	1.2.5	Source 1999 P1 qu.15

<ul style="list-style-type: none"> •¹ $a = -2$ •² $1 = \log_b(7-2)$ •³ $b = 5$ 	OR	<ul style="list-style-type: none"> •¹ $1 = \log_b(7+a)$ and $0 = \log_b(a+3)$ •² $7+a = b$ and $a+3 = b^0$ •³ $a = -2, b = 5$
---	----	--

A curve has equation $y = 2x^3 + 3x^2 + 4x - 5$.
Prove that this curve has no stationary points.

5

part marks	Unit	non-calc		calc		calc neut		Content Reference :		1.3
		C	A/B	C	A/B	C	A/B	Main	Additional	
5	1.3	2	3					1.3.12	1.3.11	Source 1999 P1 qu.16

<ul style="list-style-type: none"> •¹ $\frac{dy}{dx} = \dots\dots$ •² $6x^2 + 6x + 4$ •³ e.g. "$b^2 - 4ac$" = •⁴ -60 or -15 (from $3x^2 + 3x + 2$) •⁵ Δ negative so no st. points 	OR	<ul style="list-style-type: none"> •¹ $\frac{dy}{dx} = \dots\dots$ •² $6x^2 + 6x + 4$ •³ e.g. complete square..... •⁴ $S = 6\left(x + \frac{1}{2}\right)^2 + 2\frac{1}{2}$ •⁵ $S \geq 2\frac{1}{2}$ so no st. points
---	----	--

The diagram shows two vectors a and b , with $|a| = 3$ and $|b| = 2\sqrt{2}$. These vectors are inclined at an angle of 45° to each other.

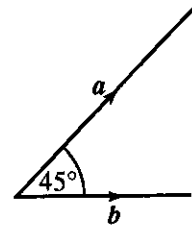

- (a) Evaluate
- (i) $a \cdot a$
 - (ii) $b \cdot b$
 - (iii) $a \cdot b$
- (b) Another vector p is defined by $p = 2a + 3b$. Evaluate $p \cdot p$ and hence write down $|p|$.

2
4

part	marks	Unit	non-calc		calc		calc neut		Content Reference :		3.1
			C	A/B	C	A/B	C	A/B	Main	Additional	
(a)	2	3.1					2		3.1.9		Source
(b)	4	3.1					4		3.1.9		1999 P1 qu.17

• ¹ $a \cdot a = 9$ and $b \cdot b = 8$	• ³ $(2a + 3b) \cdot (2a + 3b)$
• ² $a \cdot b = 6$	• ⁴ $4a \cdot a + 9b \cdot b + 12a \cdot b$
	• ⁵ 180
	• ⁶ $\sqrt{180}$

Two sequences are defined by the recurrence relations

$$u_{n+1} = 0.2u_n + p, \quad u_0 = 1 \quad \text{and}$$

$$v_{n+1} = 0.6v_n + q, \quad v_0 = 1.$$

If both sequences have the same limit, express p in terms of q .

3

part	marks	Unit	non-calc		calc		calc neut		Content Reference :		1.4
			C	A/B	C	A/B	C	A/B	Main	Additional	
.	3	1.4					3		1.4.5		Source
											1999 P1 qu.18

• ¹ " $L = 0.2L + p, \quad L = 0.6L + q$ " or use " $l = \frac{b}{1-a}$ "
• ² $\frac{p}{0.8}$ and $\frac{q}{0.4}$
• ³ $p = \frac{0.8q}{0.4}$ or equivalent expression for p

Given $f(x) = \cos^2 x - \sin^2 x$, find $f'(x)$.

3

part marks	Unit	non-calc		calc		calc neut		Content Reference :		3.2
		C	A/B	C	A/B	C	A/B	Main	Additional	
3	3.2	1	2					3.2.2	3.2.1	Source 1999 P1 qu.19

<ul style="list-style-type: none"> •¹ $f(x) = \cos 2x$ •² $-\sin 2x$ •³ $\times 2$ 	<p>For $\frac{d}{dx}(\cos^2 x)$ OR For $\frac{d}{dx}(-\sin^2 x)$</p> <ul style="list-style-type: none"> •¹ $2 \cos x$ •² $\times -\sin x$ <p>For $\frac{d}{dx}(-\sin^2 x)$ For $\frac{d}{dx}(\cos^2 x)$</p> <ul style="list-style-type: none"> •³ $-2 \sin x \times \cos x$ •³ $2 \cos x \times -\sin x$
---	---

Find $\int \frac{x^2 - 5}{x\sqrt{x}} dx$.

4

part marks	Unit	non-calc		calc		calc neut		Content Reference :		2.2
		C	A/B	C	A/B	C	A/B	Main	Additional	
4	2.2	2	2					2.2.4		Source 1999 P1 qu.20

<ul style="list-style-type: none"> •¹ $\left(\frac{x^2}{x\sqrt{x}}\right) x^{\frac{1}{2}}$ •² $\left(\frac{-5}{x\sqrt{x}}\right) -5x^{-\frac{3}{2}}$ 	<ul style="list-style-type: none"> •³ $\frac{x^{\frac{3}{2}}}{\frac{3}{2}}$ •⁴ $\frac{-5}{-\frac{1}{2}} x^{-\frac{1}{2}}$
--	---

A function f can be expressed as an infinite series by $f(x) = 1 + x + \frac{x^2}{2} + \frac{x^3}{6} + \frac{x^4}{24} + \frac{x^5}{120} + \dots$

(a) Write down the series for $f(2x)$ as far as the term in x^5 .

1

The derivative of $f(x)$ can be calculated as follows:

$$\begin{aligned}
 f(x) &= 1 + x + \frac{x^2}{2} + \frac{x^3}{6} + \frac{x^4}{24} + \frac{x^5}{120} + \dots \\
 \text{so } f'(x) &= 0 + 1 + \frac{2x}{2} + \frac{3x^2}{6} + \frac{4x^3}{24} + \frac{5x^4}{120} + \dots \\
 &= 1 + x + \frac{x^2}{2} + \frac{x^3}{6} + \frac{x^4}{24} + \dots \\
 \text{i.e. } f'(x) &= f(x)
 \end{aligned}$$

(b) If $g(x) = f(2x)$ find $g'(x)$ and express it in terms of $f(2x)$.

3

part	marks	Unit	non-calc		calc		calc neut		Content Reference :		0.1
			C	A/B	C	A/B	C	A/B	Main	Additional	
(a)	1	0.1						1	0.1		Source
(b)	3	0.1						3	0.1	1.3.4	1999 P1 qu.21

•¹ $1 + 2x + \frac{(2x)^2}{2} + \frac{(2x)^3}{6} + \frac{(2x)^4}{24} + \frac{(2x)^5}{120}$

•² $1 + 2x + 2x^2 + \frac{4}{3}x^3 + \frac{2}{3}x^4 + \frac{4}{15}x^5$

•³ $2 + 4x + 4x^2 + \frac{8}{3}x^3 + \frac{4}{3}x^4$

•⁴ $2\left(1 + 2x + 2x^2 + \frac{4}{3}x^3 + \frac{2}{3}x^4\right)$ **and** $2f(2x)$

(New) Section 5

EXTENDED RESPONSE QUESTION ANALYSIS

Pages 1-11

marks distribution

Main Unit & Outcome part	marks	Unit	marks distribution						Content Main	Reference : Additional	E.R.Q. page no.	Source
			non calc		calc		calc neut					
			C	A/B	C	A/B	C	A/B				
2.2	(a)	2	1.2	2					1.2.9		103	SQA : H : PII
	(b)	6	1.3	6					1.3.12			1989 Qu.1
	(c)	2	1.3	2					1.3.13			
	(d)	4	2.2	4					2.2.6			
3.1	(a)	1	0.1				1		0.1		104	SQA : H : PII
	(b)	3	3.1				3		3.1.6			1989 Qu.2
	(c)	4	3.1				4		3.1.7	3.1.6		
2.1	(a)	3	0.1	3					0.1		105	SQA : H : PII
	(b)	1	0.1	1					0.1			1989 Qu.3
	(c)	4	2.1	1	3				2.1.11			
1.2	(a)	4	1.2		4				1.2.4		106	SQA : H : PII
	(b)	2	1.2		2				1.2.1			1989 Qu.4
	(c)	3	1.2		3				1.2.7			
2.4		6	2.4			6			2.4.2	2.4.4	107	SQA : H : PII
												1989 Qu.5
1.4	(a)	5	1.4			5			1.4.1	1.4.5	108	SQA : H : PII
	(b)	1	0.1			1			0.1			1989 Qu.6
1.3	(a)	2	0.1				2		0.1		109	SQA : H : PII
	(b)	6	1.3				3	3	1.3.15			1989 Qu.7
0.1	(a)	4	0.1	4					0.1		110	SQA : H : PII
	(b)	5	3.2	2	3				3.2.1	3.2.4		1989 Qu.8
	(c)	2	1.2	2					1.2.3			
	(d)	2	0.1		2				0.1			
3.4	(a)	4	3.4			4			3.4.1		111	SQA : H : PII
	(b)	6	1.2			2	4		1.2.3	1.2.4		1989 Qu.9
	(c)	1	0.1				1		0.1			
	(d)	2	0.1				2		0.1			
2.2	(a)	5	1.1	3	2				1.1.3	1.1.10	112	SQA : H : PII
	(b)	4	1.1	1	3				1.1.7	0.1		1989 Qu.10
	(c)	6	2.2		6				2.2.6			

marks distribution

Main Unit & Outcome part	marks	Unit	non calc		calc		calc neut		Content Main	Reference : Additional	E.R.Q. page no.	Source
			C	A/B	C	A/B	C	A/B				
1.3	(a)	3	1.2	3					1.2.9		93	SQA : H : PII 1990Qu.1
	(b)	7	1.3	7					1.3.12			
	(c)	2	1.3	2					1.3.13			
1.1	(a)	7	1.1					7	1.1.10 0.1		94	SQA : H : PII 1990Qu.2
	(b)	2	0.1					2	0.1			
1.4	(a)	3	1.4			3			1.4.2		95	SQA : H : PII 1990Qu.3
	(b)	5	1.4			5			1.4.2			
3.1	(a)	3	3.1			3			3.1.6		96	SQA : H : PII 1990Qu.4
	(b)	5	3.1			5			3.1.11			
3.4	(a)	3	2.3			3			2.3.2 1.2.11		97	SQA : H : PII 1990Qu.5
	(b)	4	3.4			4			3.4.1			
	(c)	3	3.4					3	3.4.2			
2.1	(a)	4	1.2	4					1.2.6		98	SQA : H : PII 1990Qu.6
	(b)	3	2.1	3					2.1.3			
	(c)	2	1.2	2					1.2.1			
2.2	(a)	6	2.2	3	3				2.2.7		99	SQA : H : PII 1990Qu.7
	(b)	4	2.2	2	2				2.2.5 0.1			
	(c)	4	0.1			4			0.1			
2.4	(a)	4	2.4					4	2.4.3		100	SQA : H : PII 1990Qu.8
	(b)	7	2.4					3 4	2.4.4			
0.1	(a)	3	2.1			3			2.1.11		101	SQA : H : PII 1990Qu.9
	(b)	6	0.1			3	3		0.1			
1.2	(a)	4	1.2		4				1.2.3		102	SQA : H : PII 1990Qu.10
	(b)	3	1.2		3				1.2.4			
	(c)	3	1.2		3				1.2.9			

Main Unit & Outcome	part	marks	Unit	marks distribution						Content Reference :		E.R.Q. page no.	Source
				non calc		calc		calc neut		Main	Additional		
				C	A/B	C	A/B	C	A/B				
1.3	(a)	5	1.3					5		1.3.12		82	SQA : H : PII
	(b)	2	1.2					2		1.2.1			1991 Qu.1
2.4	(a)	4	1.1					4		1.1.9	1.1.7	83	SQA : H : PII
	(b)	6	2.4					6		2.4.3	1.1.2		1991 Qu.2
1.2	(a)	3	1.2			3				1.2.5		85	SQA : H : PII
	(b)	3	0.1			1	2			0.1			1991 Qu.4
3.1	(a)	7	3.1			7				3.1.11	3.3.1	86	SQA : H : PII
	(b)	3	0.1			3				0.1			1991 Qu.5
0.1		5	0.1			5				0.1		87	SQA : H : PII 1991 Qu.6
3.3	(a)	5	3.3			2	3			3.3.4		88	SQA : H : PII
	(b)	4	3.3			1	3			3.3.4			1991 Qu.7
3.4	(a)	4	3.4			4				3.4.1		89	SQA : H : PII
	(b)	4	1.2			2	2			1.2.3			1991 Qu.8
	(c)	3	2.3			1	2			2.3.1			
1.4	(a)	4	1.4			4				1.4.1		90	SQA : H : PII
	(b)	6	1.4			4	2			1.4.3	1.4.5		1991 Qu.9
2.1	(a)	4	1.2					1	3	1.2.7		91	SQA : H : PII
	(b)	7	2.1					3	4	2.1.8	1.1.1 1.1.7		1991 Qu.10
2.2	(a)	5	1.3	5						1.3.9	1.1.7	92	SQA : H : PII
	(b)	2	0.1	2						0.1			1991 Qu.11
	(c)	3	2.2	3						2.2.6			
	(d)	3	0.1	1	2					0.1			
2.3	(a)	3	0.1					2	1	0.1		84	SQA : H : PII
	(b)	5	2.3					5		2.3.5	0.1		1991 Qu.12

Main Unit & Outcome part	marks	Unit	marks distribution						Content Main	Reference : Additional	E.R.Q. page no.	Source
			non calc		calc		calc neut					
			C	A/B	C	A/B	C	A/B				
2.1	(a)	3	2.1	3					2.1.3		72	SQA : H : PII
	(b)	2	1.2	2					1.2.9			1992 Qu.1
	(c)	6	1.3	6					1.3.12			
3.1	(a)	3	3.1			3			3.1.3		73	SQA : H : PII
	(b)	2	3.1			2			3.1.3			1992 Qu.2
	(c)	3	3.1			3			3.1.10			
	(d)	5	3.1			5			3.1.11			
1.4	(a)	3	1.4			3			1.4.3		74	SQA : H : PII
	(b)	5	1.4			5			1.4.3 1.4.5			1992 Qu.3
3.3	(a)	2	3.3			2			3.3.4		75	SQA : H : PII
	(b)	3	3.3			1	2		3.3.4			1992 Qu.4
	(c)	3	1.2			1	2		1.2.5			
1.3	(a)	4	0.1	2	2				0.1		76	SQA : H : PII
	(b)	6	1.3	4	2				1.3.15			1992 Qu.5
3.1	(a)	3	0.1					3	0.1		77	SQA : H : PII
	(b)	4	3.1					4	3.1.9 3.1.10			1992 Qu.6
2.3	(a)	4	2.3			4			2.3.5		78	SQA : H : PII
	(b)	1	1.2			1			1.2.7			1992 Qu.7
	(c)	2	1.2			2			1.2.9			
	(d)	3	1.2			2	1		1.2.10			
2.3	(a)	2	0.1			1	1		0.1		79	SQA : H : PII
	(b)	3	2.3				3		2.3.4			1992 Qu.8
	(c)	3	0.1			3			0.1			
2.4	(a)	3	1.1					3	1.1.1 1.1.7		80	SQA : H : PII
	(b)	1	2.4					1	2.4.3			1992 Qu.9
	(c)	5	2.4					2	3	2.4.4		
3.4	(a)	4	2.2			4			2.2.6		81	SQA : H : PII
	(b)	2	0.1			2			0.1			1992 Qu.10
	(c)	10	3.4			2	8		3.4.2 3.2.1 2.2.7			

Main Unit & Outcome part	marks	Unit	marks distribution						Content Main	Reference : Additional	E.R.Q. page no.	Source
			non calc		calc		calc neut					
			C	A/B	C	A/B	C	A/B				
2.1	8	2.1					8		2.1.3	1.3.12	61	SQA : H : PII 1993Qu.1
2.2	(a)	2	0.1	2					0.1		62	SQA : H : PII
	(b)	4	2.2	4					2.2.6			1993Qu.2
2.4	(a)	3	1.1				3		1.1.9	1.1.7	63	SQA : H : PII
	(b)	5	2.4				5		2.4.3			1993Qu.3
0.1	(a)	3	0.1				3		0.1		64	SQA : H : PII
	(b)	5	2.1				5		2.1.7	0.1		1993Qu.4
3.1	(a)	3	3.1				3		3.1.6		65	SQA : H : PII
	(b)	4	3.1				4		3.1.3	0.1		1993Qu.5
	(c)	5	0.1				5		0.1			
2.3	(a)	5	2.3	3	2				2.3.1		66	SQA : H : PII
	(b)	1	0.1	1					0.1			1993Qu.6
	(c)	3	0.1		3				0.1			
2.1	(a)	7	2.1	7					2.1.8	2.1.3	67	SQA : H : PII
	(b)	1	2.1		1				2.1.8			1993Qu.7
1.4	(a)	3	1.4				3		1.4.1		68	SQA : H : PII
	(b)	3	1.4				3		1.4.1			1993Qu.8
	(c)	1	1.4				1		1.4.3			
	(d)	4	1.4				3	1	1.4.4	1.4.5		
3.4	(a)	5	0.1				1	4	0.1	2.3.3	69	SQA : H : PII
	(b)	4	3.4				4		3.4.1			1993Qu.9
	(c)	4	3.4				1	3	3.4.2			
3.3	(a)	3	1.1				3		1.1.1	1.1.7	70	SQA : H : PII
	(b)	4	3.3				4		3.3.6			1993Qu.10
3.2	(a)	3	0.1	1	2				0.1		71	SQA : H : PII
	(b)	7	1.3	1	6				1.3.15	3.2.2		1993Qu.11

marks distribution

Main Unit & Outcome	part	marks	Unit	non calc		calc		calc neut		Content Main	Reference : Additional	E.R.Q. page no.	Source
				C	A/B	C	A/B	C	A/B				
2.1	(a)	3	2.1	3						2.1.3		50	SQA : H : PII
	(b)	4	2.1	4						2.1.3			1994 Qu.1
1.1	(a)	3	1.1					3		1.1.9	1.1.7	51	SQA : H : PII
	(b)	3	0.1					3		0.1			1994 Qu.2
	(c)	2	1.1					2		1.1.2			
3.1	(a)	3	3.1			3				3.1.1		52	SQA : H : PII
	(b)	1	3.1			1				3.1.6			1994 Qu.3
	(c)	4	3.1			4				3.1.11			
	(d)	2	0.1			2				0.1			
2.4	(a)	8	2.4			8				2.4.2	1.1.2	53	SQA : H : PII
	(b)	8	1.1			8				1.1.1	1.1.9 2.4.4		1994 Qu.4
3.4	(a)	4	3.4			4				3.4.1		54	SQA : H : PII
	(b)	4	3.4			4				3.4.2			1994 Qu.5
	(c)	2	3.4					2		3.4.2			
0.1	(a)	2	0.1			2				0.1		55	SQA : H : PII
	(b)	6	0.1			6				0.1			1994 Qu.6
1.3	(a)	4	0.1	4						0.1		57	SQA : H : PII
	(B)	8	1.3	3	5					1.3.15			1994 Qu.7
0.1	(a)	5	0.1					5		0.1		58	SQA : H : PII
	(b)	4	0.1					4		0.1			1994 Qu.8
	(c)	2	0.1					2		0.1			
2.1	(a)	1	0.1					1		0.1		59	SQA : H : PII
	(b)	6	1.3					2	4	1.3.7	0.1		1994 Qu.9
	(c)	2	2.1						2	2.1.6			
2.2		9	2.2				3	6	2.2.7	0.1	60	SQA : H : PII	
													1994 Qu.10

Main Unit & Outcome part	marks	Unit	marks distribution						Content Reference :			ER.Q. page no.	Source
			non calc		calc		calc neut		Main	Additional			
			C	A/B	C	A/B	C	A/B					
1.1	(a)	2	1.1					2		1.1.2		38	SQA : H : PII
	(b)	8	1.1					8		1.1.10 0.1			1995Qu.1
2.1	(a)	4	1.3	4						1.3.9 1.1.7		39	SQA : H : PII
	(b)	5	2.1	5						2.1.2 2.1.8			1995Qu.2
1.4		7	1.4			7				1.4.3 1.4.4 1.4.5		40	SQA : H : PII 1995Qu.3
3.4	(a)	4	2.3			4				2.3.2		41	SQA : H : PII
	(b)	5	3.4			5				3.4.1			1995Qu.4
3.1	(a)	4	3.1					4		3.1.11		42	SQA : H : PII
	(b)	6	3.1					6		3.1.6 3.1.3			1995Qu.5
	(c)	2	3.1					1	1	3.1.3 0.1			
0.1		7	0.1					7		0.1		43	SQA : H : PII 1995Qu.6
1.3		8	1.3	2	6					1.1.3 1.3.7 0.1		45	SQA : H : PII 1995Qu.7
3.1		8	3.1					8		2.4.1 2.4.3 3.1.6		46	SQA : H : PII 1995Qu.8
3.2	(a)	4	2.3	2	2					2.3.2 2.3.3		47	SQA : H : PII
	(b)	4	3.2			4				3.2.4			1995Qu.9
2.2	(a)	5	2.2	5						2.2.7		48	SQA : H : PII
	(b)	3	2.2			3				2.2.5			1995Qu.10
	(c)	5	2.1	2	3					2.1.3 0.1			
3.2	(a)	1	0.1						1	0.1		49	SQA : H : PII
	(b)	5	3.2					1	4	3.2.2			1995Qu.11
	(c)	3	1.3					1	2	1.3.15			

marks distribution

Main Unit & Outcome part	marks	Unit	non calc		calc		calc neut		Content Main	Reference : Additional	E.R.Q. page no.	Source
			C	A/B	C	A/B	C	A/B				
1.3	(a)	6	1.3	6					1.3.12		25	SQA : H : PII
	(b)	2	1.3	2					1.3.12			1996Qu.1
1.1	(a)	3	1.1					3	1.1.10		26	SQA : H : PII
	(b)i	5	1.1					5	1.1.10			1996Qu.2
	(b)ii	3	0.1					3	0.1			
3.1	(a)	2	3.1			2			3.1.1		27	SQA : H : PII
	(b)	7	3.1			7			3.1.11			1996Qu.3
2.1	(a)	4	1.2	4					1.2.6		28	SQA : H : PII
	(b)	7	2.1	7					2.1.6	2.1.7 0.1		1996Qu.4
3.2		6	3.2	2	4				3.2.4	2.2.6	29	SQA : H : PII 1996Qu.5
2.1	(a)	3	1.2					3	1.2.7		30	SQA : H : PII
	(b)	4	0.1					4	0.1			1996Qu.6
	(c)	4	2.1					4	2.1.8	0.1		
3.4	(a)	4	3.4			4			3.4.1		32	SQA : H : PII
	(b)	3	3.4			3			3.4.2			1996Qu.7
2.2	(a)	8	2.1					5	2.1.8	1.1.7 1.3.9	33	SQA : H : PII
	(b)	3	2.2					3	2.2.7			1996Qu.8
3.3	(a)	3	1.1			3			1.1.7		34	SQA : H : PII
	(b)	4	3.3					4	3.3.6			1996Qu.9
2.4	(a)	6	2.4					3	2.4.1	1.1.9 1.3.9	35	SQA : H : PII
	(b)	4	2.4					4	2.4.4			1996Qu.10
1.3	(a)	4	0.1					1	0.1		37	SQA : H : PII
	(b)	5	1.3					2	1.3.15			1996Qu.11

marks distribution

Main Unit & Outcome	part	marks	Unit	non calc		calc		calc neut		Content Main	Reference : Additional	E.R.Q. page no.	Source
				C	A/B	C	A/B	C	A/B				
2.4	(a)	5	2.4					5		2.4.4		13	SQA : H : PII 1997 Qu.1
	(b)i	1	2.4					1		2.4.2			
	(b)ii	3	1.1					3		1.1.10 1.1.7			
3.1	(a)	3	3.1			3				3.1.6		14	SQA : H : PII 1997 Qu.2
	(b)	7	3.1			7				3.1.11			
1.4	(a)	4	1.4			4				1.4.1		15	SQA : H : PII 1997 Qu.3
	(b)	2	1.4			2				1.4.1			
	(c)	3	1.4			3				1.4.3			
2.2	(a)	2	2.1	2						2.1.2		16	SQA : H : PII 1997 Qu.4
	(b)	7	2.2	6	1					2.2.6			
2.2	(a)	3	1.2	3						1.2.9		17	SQA : H : PII 1997 Qu.5
	(b)	5	2.2	5						2.2.7			
	(c)	3	0.1		2					0.1			
1.3	(a)	4	1.3					4		1.3.7		18	SQA : H : PII 1997 Qu.6
	(b)	2	1.1					1	1	1.1.7			
	(c)	4	0.1						4	0.1			
0.1		6	0.1					6		0.1		19	SQA : H : PII 1997 Qu.7
3.3	(a)	3	3.3			1	2			3.3.7		21	SQA : H : PII 1997 Qu.8
	(b)	3	3.3				3			3.3.7			
2.3	(a)	4	1.2			2	2			1.2.3		22	SQA : H : PII 1997 Qu.9
	(b)	4	2.3				4			2.3.1			
1.3	(a)	4	0.1					1	3	0.1		23	SQA : H : PII 1997 Qu.10
	(b)	6	1.3					3	3	1.3.15			
3.4	(a)	3	0.1	2	1					0.1		24	SQA : H : PII 1997 Qu.11
	(b)	6	3.4	4	2					3.4.1 3.4.3			
	(c)	4	0.1	1	3					0.1			

Main Unit & Outcome part	marks	Unit	marks distribution						Content Reference :			E.R.Q. page no.	Source	
			non calc		calc		calc neut		Main	Additional				
			C	A/B	C	A/B	C	A/B						
3.1	(a)	2	3.1			2				3.1.1			1	SQA : H : PII
	(b)	5	3.1			5				3.1.11				1998Qu.1
	(c)	2	0.1			2				0.1				
1.3	(a)	6	1.3					6		1.3.12			2	SQA : H : PII
	(b)	2	1.3					2		1.3.12				1998Qu.2
1.3	(a)	5	1.3					5		1.1.7	1.3.9	1.1.6	3	SQA : H : PII
	(b)	2	1.1					2		1.1.3	1.1.9			1998Qu.3
2.2	(a)	2	1.2	2						1.2.7			4	SQA : H : PII
	(b)	4	2.2	4						2.2.6				1998Qu.4
	(c)i	2	2.1	2						2.1.8				
	(c)ii	3			3					2.2.7				
2.1	(a)i	1	0.1	1						0.1			5	SQA : H : PII
	(a)ii	4	1.1	4						1.1.6	0.1			1998Qu.5
	(b)	7	2.1	2	5					2.1.12	2.1.2			
2.4	(a)	3	2.4					3		2.4.3			6	SQA : H : PII
	(b)	3	2.4					3		2.4.2	3.1.6			1998Qu.6
	(c)	3	0.1					3		0.1				
3.4	(a)	4	3.4			4				3.4.1			7	SQA : H : PII
	(b)	4	3.4			1	3			3.4.3				1998Qu.7
	(c)	1	0.1				1			0.1				
1.4	(a)	3	1.4			3				1.4.1			8	SQA : H : PII
	(b)	1	1.4			1				1.4.3				1998Qu.8
	(c)	4	1.4			4				1.4.4	1.4.5			
0.1	(a)	4	2.2					4		2.2.5			9	SQA : H : PII
	(b)	4	2.2					4		2.2.5				1998Qu.9
	(c)	1	0.1					1		0.1				
1.3	(a)	3	0.1				3			0.1			11	SQA : H : PII
	(b)	6	1.3			3	3			1.3.15				1998Qu.10
3.3	(a)	3	3.3				3			3.3.7			12	SQA : H : PII
	(b)	6	3.3				6			3.3.5				1998Qu.11

Main Unit & Outcome part	marks	Unit	marks distribution						Content Main	Reference : Additional	E.R.Q. page no.	Source		
			non calc		calc		calc neut							
			C	A/B	C	A/B	C	A/B						
1.1	(a)	3	1.1					3		1.1.7		113	SQA : H : PII	
	(b)	3	1.1					3		1.1.7	1.1.9		1999 Qu.1	
	(c)	3	0.1					3		0.1				
2.4	(a)	4	2.4					4		2.4.2	1.1.9		114	SQA : H : PII
	(b)	1	0.1					1		0.1				1999 Qu.2
	(c)	1	0.1					1		0.1				
	(d)	2	2.4					2		2.4.4				
3.1	(a)	2	3.1					2		3.1.2			115	SQA : H : PII
	(b)	2	3.1					2		3.1.2				1999 Qu.3
	(c)	5	3.1					5		3.1.11				
2.1	(a)	2	1.2	2						1.2.9			116	SQA : H : PII
	(b)	2	1.1	2						1.1.7				1999 Qu.4
	(c)	4	2.1	4						2.1.8				
1.3	(a)	4	0.1			2	2			0.1			117	SQA : H : PII
	(b)	6	1.3			6				1.3.15				1999 Qu.5
2.2	(a)	4	1.2	4						1.2.6			118	SQA : H : PII
	(b)	3	1.2	3						1.2.9	0.1			1999 Qu.6
	(c)	4	2.2	4						2.2.6				
3.3	(a)	4	3.3			2	2			3.3.7			119	SQA : H : PII
	(b)	3	3.3			1	2			3.3.7				1999 Qu.7
2.3	a-c	3	0.1	2	1					0.1			120	SQA : H : PII
	(d)	4	2.3		4					2.3.2	1.1.1			1999 Qu.8
	(e)	2			2					1.1.8	1.1.9			
3.4	.	8	3.4				8			3.4.2			121	SQA : H : PII
														1999 Qu.9
2.2	(a)	2	1.2	2						1.2.9			122	SQA : H : PII
	(b)	7	2.2		7					2.2.7				1999 Qu.10
1.3	(a)	6	1.3					6		1.3.9	1.1.7		123	SQA : H : PII
	(b)	6	1.1					6		1.1.10	1.1.2			1999 Qu.11

(New) Section 6

EXTENDED RESPONSE QUESTIONS

Pages 113-123

(TO BE ADDED TO EXISTING ITEMS – PAGES 1-112)

Please also replace the existing pages 59 and 60 with the replacement page included at the end of this section.

A triangle ABC has vertices A (-4, 1), B (12, 3) and C (7, -7).

- Find the equation of the median CM.
- Find the equation of the altitude AD.
- Find the coordinates of the point of intersection of CM and AD.

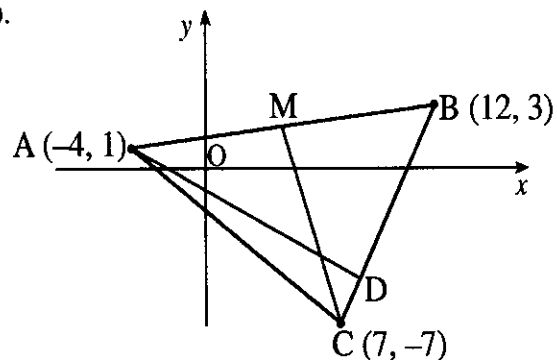

3
3
3

part	marks	Unit	non-calc		calc		calc neut		Content Reference :		1.1
			C	A/B	C	A/B	C	A/B	Main	Additional	
(a)	3	1.1					3		1.1.7		Source 1999 Paper 2 Qu. 1
(b)	3	1.1					3		1.1.7	1.1.9	
(c)	3	0.1					3		0.1		

- ¹ midpoint = (4, 2)
 - ² $m_{MC} = -3$
 - ³ $y - 2 = -3(x - 4)$ **or** $y - (-7) = -3(x - 7)$
- ⁴ $m_{BC} = 2$
 - ⁵ $m_{\perp} = -\frac{1}{2}$
 - ⁶ $y - 1 = -\frac{1}{2}(x - (-4))$
- ⁷ e.g. $3x + y = 14$ and $x + 2y = -2$
 - ⁸ attempt to eliminate a variable
 - ⁹ (6, -4)

- (a) The diagram shows a circle, centre P, with equation $x^2 + y^2 + 6x + 4y + 8 = 0$.
Find the equation of the tangent at the point A(-1, -1) on the circle.

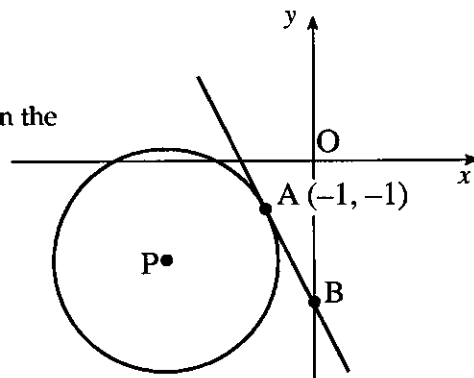

- (b) The tangent crosses the y -axis at B.
Find the coordinates of B.

- (c) Another circle, centre P, is drawn passing through B. The tangent at A meets the second circle at the point C, as shown in the diagram.
Write down the coordinates of C.

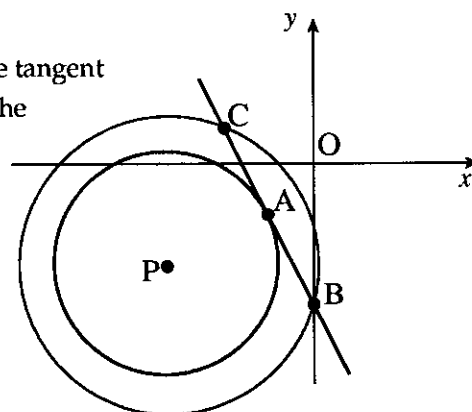

- (d) Find the equation of the circle with BC as diameter.

part	marks	Unit	non-calc		calc		calc neut		Content Reference :		2.4
			C	A/B	C	A/B	C	A/B	Main	Additional	
(a)	4	2.4					4		2.4.2	1.1.9	Source 1999 Paper 2 Qu. 2
(b)	1	0.1					1		0.1		
(c)	1	0.1					1		0.1		
(d)	2	2.4					2		2.4.4		

- (a) •¹ centre = (-3, -2)
•² $m_{rad} = \frac{1}{2}$
•³ $m_{tgt} = -2$
•⁴ $y - (-1) = -2(x - (-1))$

(b) •⁵ $B = (0, -3)$

(c) •⁶ $C = (-2, 1)$

(d) •⁷ $r^2 = 5$

•⁸ $(x+1)^2 + (y+1)^2 = 5$

ABCDEFGH is a cuboid.

K lies two thirds of the way along HG.
 (i.e. HK:KG = 2:1).
 L lies one quarter of the way along FG.
 (i.e. FL:LG = 1:3).

\vec{AB} , \vec{AD} and \vec{AE} can be represented by the vectors

$$\begin{pmatrix} 3 \\ 6 \\ 3 \end{pmatrix}, \begin{pmatrix} -8 \\ 4 \\ 4 \end{pmatrix} \text{ and } \begin{pmatrix} 1 \\ -3 \\ 5 \end{pmatrix} \text{ respectively.}$$

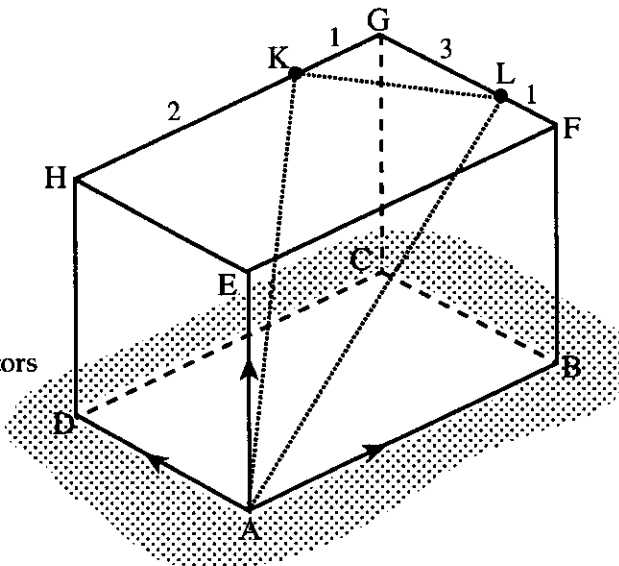

- (a) Calculate the components of \vec{AK} . 2
 (b) Calculate the components of \vec{AL} . 2
 (c) Calculate the size of angle KAL. 5

part	marks	Unit	non-calc		calc		calc neut		Content Reference :		3.1
			C	A/B	C	A/B	C	A/B	Main	Additional	
(a)	2	3.1					2		3.1.2		Source 1999 Paper 2 Qu. 3
(b)	2	3.1					2		3.1.2		
(c)	5	3.1					5		3.1.11		

<p>(a) •¹ obtaining for example $\begin{pmatrix} 2 \\ 4 \\ 2 \end{pmatrix}$</p> <p>•² $\vec{AK} = \begin{pmatrix} -5 \\ 5 \\ 11 \end{pmatrix}$</p>	<p>(c) •⁵ strategy e.g. $\cos \hat{KAL} = \frac{\vec{AK} \cdot \vec{AL}}{ \vec{AK} \vec{AL} }$</p> <p>•⁶ 109</p> <p>•⁷ $\sqrt{171}$</p> <p>•⁸ $\sqrt{101}$</p> <p>•⁹ $\hat{A} = 34.0$</p>
OR	
<p>(b) •³ obtaining for example $\begin{pmatrix} -2 \\ 1 \\ 1 \end{pmatrix}$</p> <p>•⁴ $\vec{AL} = \begin{pmatrix} 2 \\ 4 \\ 9 \end{pmatrix}$</p>	<p>•⁵ strategy e.g. $\cos \hat{KAL} = \frac{AK^2 + AL^2 - KL^2}{2AK \times AL}$</p> <p>•⁶ $\sqrt{54}$</p> <p>•⁷ $\sqrt{171}$</p> <p>•⁸ $\sqrt{101}$</p> <p>•⁹ $\hat{A} = 34.0$</p>

The parabola shown in the diagram has equation $y = 4x - x^2$ and intersects the x -axis at the origin and P.

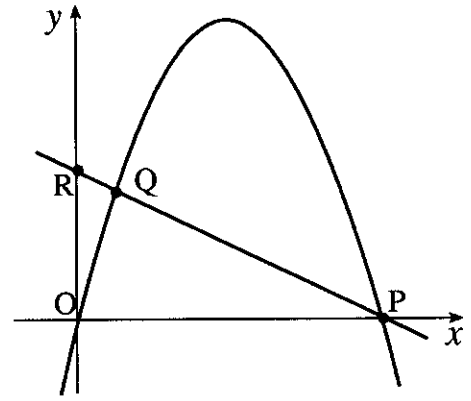

- (a) Find the coordinates of the point P. 2
 (b) R is the point (0, 2). Find the equation of PR. 2
 (c) The line and the parabola also intersect at Q. Find the coordinates of Q. 4

part	marks	Unit	non-calc		calc		calc neut		Content Reference :		2.1
			C	A/B	C	A/B	C	A/B	Main	Additional	
(a)	2	1.2	2						1.2.9		Source 1999 Paper 2 Qu. 4
(b)	2	1.1	2					1.1.7			
(c)	4	2.1	4					2.1.8			

(a) •¹ $4x - x^2 = 0$ *stated or implied by* •²

•² (4, 0)

(b) •³ $m = -\frac{1}{2}$

•⁴ $y = -\frac{1}{2}x + 2$

or $y - 2 = -\frac{1}{2}(x - 0)$

or $y - 0 = -\frac{1}{2}(x - 4)$

(c) •⁵ $4x - x^2 = 2 - \frac{1}{2}x$

•⁶ e.g. $2x^2 - 9x + 4 = 0$

•⁷ $x = \frac{1}{2}, x = 4$

•⁸ Q is $(\frac{1}{2}, \frac{7}{4})$

A zookeeper wants to fence off six individual animal pens.

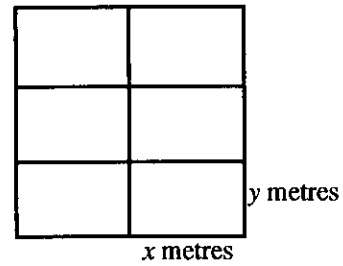
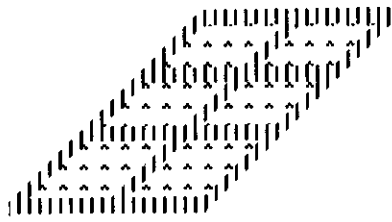

Each pen is a rectangle measuring x metres by y metres, as shown in the diagram.

- (a) (i) Express the total length of fencing in terms of x and y .
 (ii) Given that the total length of fencing is 360m, show that the total area, $A \text{ m}^2$, of the six pens is given by $A(x) = 240x - \frac{16}{3}x^2$. 4
- (b) Find the values of x and y which give the maximum area and write down this maximum area. 6

part	marks	Unit	non-calc		calc		calc neut		Content Reference :		1.3
			C	A/B	C	A/B	C	A/B	Main	Additional	
(a)	4	0.1					2	2	0.1		Source 1999 Paper 2 Qu. 5
(b)	6	1.3					6		1.3.15		

<p>(a) •¹ $9y + 8x$ •² $A = 3y \times 2x$ •³ $9y = (360 - 8x)$ •⁴ $2x \cdot 3 \cdot \frac{1}{9}(360 - 8x)$ and complete proof</p>	<p>(b) •⁵ $A'(x) = \dots\dots$ •⁶ $240 - \frac{32}{3}x$ •⁷ $A'(x) = 0$ or $240 - \frac{32}{3}x = 0$ •⁸ $x = 22\frac{1}{2}$, $y = 20$ •⁹ <table style="margin-left: auto; margin-right: auto;"> <tr> <td style="border-right: 1px solid black; padding: 0 5px;">x</td> <td style="padding: 0 5px;"> </td> <td style="padding: 0 5px;">$22\frac{1}{2}^-$</td> <td style="padding: 0 5px;">$22\frac{1}{2}$</td> <td style="padding: 0 5px;">$22\frac{1}{2}^+$</td> </tr> <tr> <td style="border-right: 1px solid black; padding: 0 5px;">$A'(x)$</td> <td style="padding: 0 5px;"> </td> <td style="padding: 0 5px;">+</td> <td style="padding: 0 5px;">0</td> <td style="padding: 0 5px;">-</td> </tr> <tr> <td colspan="5" style="text-align: center;">maximum</td> </tr> </table> •¹⁰ 2700</p>	x		$22\frac{1}{2}^-$	$22\frac{1}{2}$	$22\frac{1}{2}^+$	$A'(x)$		+	0	-	maximum				
x		$22\frac{1}{2}^-$	$22\frac{1}{2}$	$22\frac{1}{2}^+$												
$A'(x)$		+	0	-												
maximum																

Functions f and g are defined on the set of real numbers by

$$f(x) = x - 1$$

$$g(x) = x^2$$

(a) Find formulae for (i) $f(g(x))$

(ii) $g(f(x))$.

4

(b) The function h is defined by $h(x) = f(g(x)) + g(f(x))$.

Show that $h(x) = 2x^2 - 2x$ and sketch the graph of h .

3

(c) Find the area enclosed between this graph and the x -axis.

4

part	marks	Unit	non-calc		calc		calc neut		Content Reference :		2.2
			C	A/B	C	A/B	C	A/B	Main	Additional	
(a)	4	1.2	4						1.2.6		Source 1999 Paper 2 Qu. 6
(b)	3	1.2	3					1.2.9	0.1		
(c)	4	2.2	4					2.2.6			

(a)	• ¹ $f(x^2)$	stated or implied by	• ²	(c)	• ⁸ $\int_0^1 (2x^2 - 2x) dx$
	• ² $x^2 - 1$				• ⁹ $[\frac{2}{3}x^3 - x^2]$
	• ³ $g(x-1)$	stated or implied by	• ⁴		• ¹⁰ $-\frac{1}{3}$
	• ⁴ $(x-1)^2$				• ¹¹ dealing with - ve
(b)	• ⁵ $(x-1)^2 + x^2 - 1$	and complete proof			
	• ⁶ sketch as shown				
	• ⁷ minimum at $(\frac{1}{2}, -\frac{1}{2})$	calculated or on sketch			

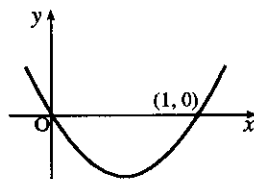

The intensity I_t of light is reduced as it passes through a filter according to the law $I_t = I_0 e^{-kt}$ where I_0 is the initial intensity and I_t is the intensity after passing through a filter of thickness t cm. k is a constant.

- (a) A filter of thickness 4 cm reduces the intensity from 120 candle-power to 90 candle-power. Find the value of k . 4
- (b) The light is passed through a filter of thickness 10 cm. Find the percentage reduction in its intensity. 3

part	marks	Unit	non-calc		calc		calc neut		Content Reference :		3.3
			C	A/B	C	A/B	C	A/B	Main	Additional	
(a)	4	3.3			2	2			3.3.7		Source 1999 Paper 2 Qu. 7
(b)	3	3.3			1	2			3.3.7		

- (a)
- ¹ $90 = 120e^{-4k}$
 - ² $e^{-4k} = 0.75$ **or** $\ln 90 = \ln 120 + \ln e^{-4k}$
 - ³ $\ln 0.75 = -4k$
 - ⁴ $k = 0.0719$
- (b)
- ⁵ $I_{10} = I_0 e^{-10 \times 0.0719}$ *stated or implied by* •⁶
 - ⁶ $\frac{I_{10}}{I_0} = 0.487$
 - ⁷ 51.3% reduction

The diagram shows a circle of radius 1 unit and centre the origin. The radius OP makes an angle a° with the positive direction of the x -axis.

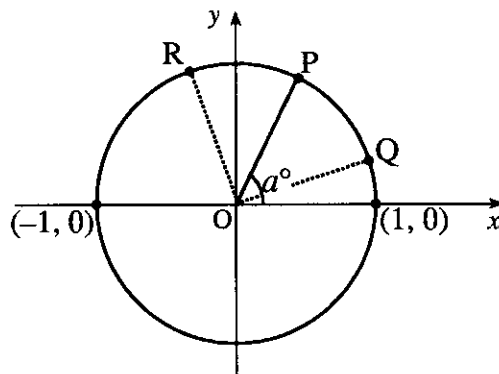
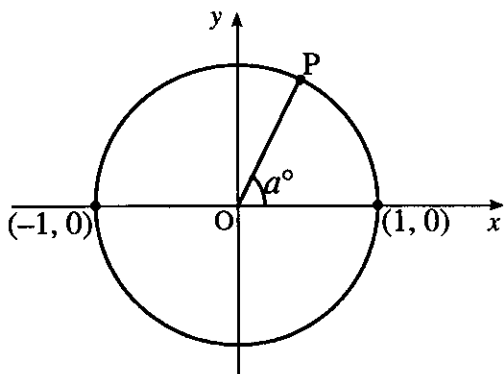

- (a) Show that P is the point $(\cos a^\circ, \sin a^\circ)$. 1
- (b) If $\widehat{POQ} = 45^\circ$, deduce the coordinates of Q in terms of a . 1
- (c) If $\widehat{POR} = 45^\circ$, deduce the coordinates of R in terms of a . 1
- (d) Hence find an expression for the gradient of QR in its simplest form. 4
- (e) Show that the tangent to the circle at P is parallel to QR. 2

part	marks	Unit	non-calc		calc		calc neut		Content Reference :		2.3
			C	A/B	C	A/B	C	A/B	Main	Additional	
(a)	1	0.1	1						0.1		Source 1999 Paper 2 Qu. 8
(b)	1	0.1	1					0.1			
(c)	1	0.1	1					0.1			
(d)	4	2.3		4				2.3.2	1.1.1		
(e)	2	1.1		2				1.1.8	1.1.9		

(a)	• ¹	proof e.g. showing rt-angled triangle with "1" and a°
(b)	• ²	Q is $(\cos(a - 45)^\circ, \sin(a - 45)^\circ)$
(c)	• ³	R is $(\cos(a + 45)^\circ, \sin(a + 45)^\circ)$
(d)	• ⁴	$\frac{\sin(a+45) - \sin(a-45)}{\cos(a+45) - \cos(a-45)}$
	• ⁵	$\frac{\sin a \cos 45 + \cos a \sin 45 - \sin a \cos 45 + \cos a \sin 45}{\cos a \cos 45 - \sin a \sin 45 - \cos a \cos 45 - \sin a \sin 45}$
	• ⁶	$\frac{2 \cos a \sin 45}{-2 \sin a \sin 45}$
	• ⁷	$-\frac{1}{\tan a}$
(e)	• ⁸	$m_{OP} = \frac{\sin a}{\cos a} = \tan a$
	• ⁹	$m_{\text{tgt at P}} = -\frac{1}{\tan a}$

part marks	Unit	non-calc		calc		calc neut		Content Reference :		3.4
		C	A/B	C	A/B	C	A/B	Main	Additional	
8	3.4				8			3.4.2		Source 1999 Paper 2 Qu. 9

<ul style="list-style-type: none"> •¹ strategy: e.g. $k \sin(x - a)$ <i>stated or implied by</i> •⁶ •² $k \sin x \cos a - k \cos x \sin a$ <i>stated explicitly</i> •³ $k \cos a = 2$ and $k \sin a = 3$ <i>stated explicitly</i> •⁴ $k = \sqrt{13}$ •⁵ $a = 56.3$ •⁶ $\sin(x - 56.3) = \frac{2.5}{\sqrt{13}}$ •⁷ $x - 56.3 = 43.9, 136.1$ <i>136.1 stated or implied by the appearance of 192.4 in</i> •⁸ •⁸ 100.2° and 192.4° <p>OR</p> <ul style="list-style-type: none"> •⁷ $x - 56.3 = 43.9, x = 100.2^\circ$ •⁸ 192.4° 	$k \cos(x - a)$ $k \cos x \cos a + k \sin x \sin a$ $k \cos a = -3, k \sin a = 2$ $k = \sqrt{13}, \tan a = -\frac{2}{3}$ $a = 146.3$ $\cos(x - 146.3) = 0.693$ $x - 146.3 = 46.1, 313.9$ $x = 192.4, 460.2$ $x = 192.4, 100.2$	$k \sin(x + a)$ $k \sin x \cos a + k \cos x \sin a$ $k \cos a = 2, k \sin a = -3$ $k = \sqrt{13}, \tan a = -\frac{3}{2}$ $a = 303.7$ $\sin(x + 303.7) = 0.693$ $x + 303.7 = 43.9, 136.1$ $x = -259.8, -167.6$ $x = 100.2, 192.4$	$k \cos(x + a)$ $k \cos x \cos a - k \sin x \sin a$ $k \cos a = -3, k \sin a = -2$ $k = \sqrt{13}, \tan a = \frac{2}{3}$ $a = 213.7$ $\cos(x + 213.7) = 0.693$ $x + 213.7 = 46.1, 313.9$ $x = -167.6, 100.2$ $x = 192.4, 100.2$
--	--	--	---

The origin, O, and the points P and Q are the vertices of a curved 'triangle' which is shaded in the diagram.

The sides lie on curves with equations

$$y = x(x+3), \quad y = x - \frac{1}{4}x^2 \quad \text{and} \quad y = \frac{4}{x^2}.$$

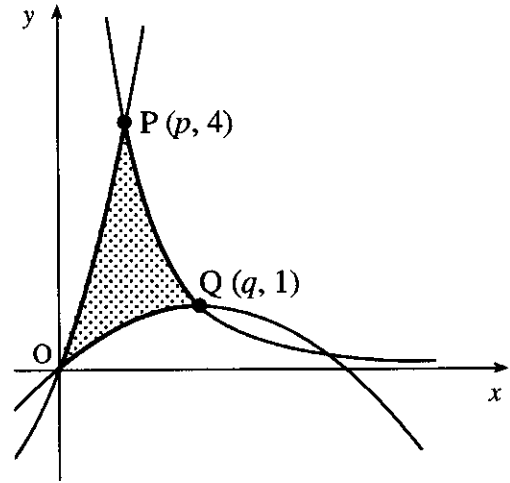

- (a) P and Q have coordinates $(p, 4)$ and $(q, 1)$. Find the values of p and q .
- (b) Calculate the shaded area.

2

7

part	marks	Unit	non-calc		calc		calc neut		Content Reference :		2.2
			C	A/B	C	A/B	C	A/B	Main	Additional	
(a)	2	1.2	2						1.2.9		Source 1999 Paper 2 Qu. 10
(b)	7	2.2		7					2.2.7		

- (a) •¹ $p = 1$
•² $q = 2$

OR

- (b) •³ $\int_0^1 ('OP' - 'OQ') dx + \int_1^2 ('PQ' - 'OQ') dx$ •³ $\int_0^1 \dots dx + \int_1^2 \dots dx - \int_0^2 \dots dx$
 •⁴ $\int_0^1 (x^2 + 3x - x + \frac{1}{4}x^2) dx$ •⁴ $\int_0^1 (x^2 + 3x) dx + \int_1^2 (4x^{-2}) dx - \int_0^2 (x - \frac{1}{4}x^2) dx$
 •⁵ $[\frac{5}{12}x^3 + x^2]$ or $[\frac{1}{3}x^3 + \frac{3}{2}x^2 - \frac{1}{2}x^2 + \frac{1}{12}x^3]$ •⁵ $[\frac{1}{3}x^3 + \frac{3}{2}x^2]$
 •⁶ $\frac{17}{12}$ •⁶ $[-4x^{-1}]$
 •⁷ $\int_1^2 (4x^{-2} - x + \frac{1}{4}x^2) dx$ •⁷ $[\frac{1}{2}x^2 - \frac{1}{12}x^3]$
 •⁸ $[-4x^{-1} - \frac{1}{2}x^2 + \frac{1}{12}x^3]$ •⁸ any two evaluations from $\frac{11}{6}, 2, \frac{4}{3}$
 •⁹ $\frac{13}{12}$ and Area = $2\frac{1}{2}$ •⁹ third evaluation and area = $\frac{11}{6} + 2 - \frac{4}{3} = 2\frac{1}{2}$

The diagram shows a sketch of the graph of $y = x^3 - 9x + 4$ and two parallel tangents drawn at P and Q.

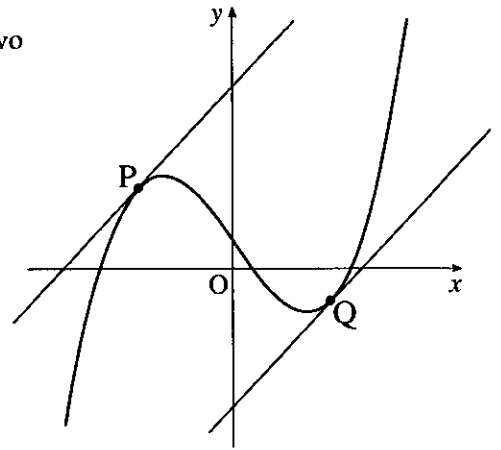

- (a) Find the equations of the tangents to the curve $y = x^3 - 9x + 4$ which have gradient 3. 6
- (b) Show that the shortest distance between the tangents is $\frac{16\sqrt{10}}{5}$. 6

part	marks	Unit	non-calc		calc		calc neut		Content Reference :		1.3
			C	A/B	C	A/B	C	A/B	Main	Additional	
(a)	6	1.3					6		1.3.9	1.1.7	Source 1999 Paper 2 Qu. 11
(b)	6	1.1						6	1.1.10		

(a)

- ¹ strategy: $\frac{dy}{dx} = \dots = 3$
- ² $3x^2 - 9$
- ³ $x = 2, -2$ **OR**
 - ³ $x = 2, y = -6$
 - ⁴ $x = -2, y = 14$
- ⁴ $y = -6, 14$
- ⁵ $y + 6 = 3(x - 2)$
- ⁶ $y - 14 = 3(x + 2)$

(b)

- ⁷ diagram with $y = -\frac{1}{3}x$
- ⁸ for 20 and 12
- ⁹ $AB = AO + OB$
- ¹⁰ $AB = 20 \cos a + 12 \cos a$
- ¹¹ using $\tan a = \frac{3}{1}$
- ¹² $AB = 32 \times \frac{1}{\sqrt{10}} = 32 \times \frac{\sqrt{10}}{10} = \frac{32}{5} \sqrt{10}$

- ⁷ $m_{RS} = -\frac{1}{3}$
- ⁸ equ of RS : $y = -\frac{1}{3}x$
- ⁹ $-\frac{1}{3}x = 3x - 12$ & $-\frac{1}{3}x = 3x + 20$
- ¹⁰ $R(-6, 2)$ and $S(\frac{18}{5}, -\frac{6}{5})$
- ¹¹ $d^2 = (-6 - (\frac{18}{5}))^2 + (2 - (-\frac{6}{5}))^2$
- ¹² $d^2 = \frac{48^2}{25} + \frac{16^2}{25}$ and completes proof

- (a) The point $A(2, 2)$ lies on the parabola $y = x^2 + px + q$.
Find a relationship between p and q .

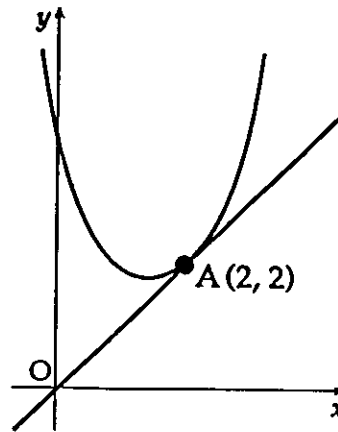

(1)

- (b) The tangent to the parabola at A is the line $y = x$. Find the value of p .
Hence find the equation of the parabola.

(6)

- (c) Using your answers for p and q , find the value of the discriminant of $x^2 + px + q = 0$. What feature of the above sketch is confirmed by this value?

(2)

part	marks	Unit	non-calc		calc		calc neut		Content Reference :		2.1
			C	A/B	C	A/B	C	A/B	Main	Additional	
(a)	1	0.1					1		0.1		Source 1994 Paper 2 Qu.9
(b)	6	1.3					2	4	1.3.7, 0.1		
(c)	2	2.1						2	2.1.6		

(a) •¹ $2p + q = -2$

(b) •² strategy

•³ $2x + p$

•⁴ gradient = 1, or equivalent

•⁵ $4 + p$

•⁶ $p = -3$

•⁷ $q = 4$

(c) •⁸ $\Delta = -7$

•⁹ $\sqrt{-7}$ means no roots

The cargo space of a small bulk carrier is 60m long.



The shaded part of the diagram represents the uniform cross-section of this space. It is shaped like the parabola with equation $y = \frac{1}{4}x^2$, $-6 \leq x \leq 6$, between the lines $y = 1$ and $y = 9$. Find the area of this cross-section and hence find the volume of cargo that this ship can carry.

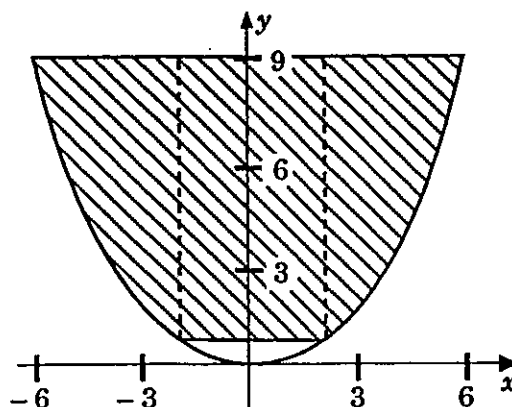

(9)

part	marks	Unit	non-calc		calc		calc neut		Content Reference :		2.2
			C	A/B	C	A/B	C	A/B	Main	Additional	
-	9	2.2					3	6	2.2.7,	0.1	Source 1994 Paper 2 Qu.10

- (-)
- ¹ strategy: split into approp. parts
 - ² $y = 1 \Rightarrow x = \pm 2$
 - ³ first rectangular area
 - ⁴ $9 - \frac{1}{4}x^2$ for integrand of shaped area
 - ⁵ $\int_2^5 dx$ for limits of shaped area
 - ⁶ for integrating..... $(9x - \frac{1}{12}x^3)$
 - ⁷ for evaluating..... $(\frac{56}{3})$
 - ⁸ total cross-sectional area = $\frac{208}{3}(m^2)$
 - ⁹ volume = $4160(m^3)$