



**S3 General Homework**  
**Calculations & Calculators**

Name

Class

Mark

**Q1.** Calculate:

(a)  $2 + 3 \times 5$

(b)  $12 - 6 \div 3$

(c)  $24 \div 6 + 2$

(d)  $(15 + 5) \div 4$

**Q2.** Round each number to the nearest 10

(a) 55

(b) 123

(c) 1728

(d) 101.01

**Q3.** Round each to the number of decimal places shown in brackets

(a) 3.76 (1)

(b) 18.324 (2)

(c) 12.8735 (3)

(d) 103.7839 (1)

**Q4.** Use your calculator to find the following. Answer to 1 dp where necessary.

(a)  $\sqrt{25^2 - 16^2}$

(b)  $8.4 \div (9.6 - 5.7)$

(c)  $20 \times (2.1 + 5.9)$

(d)  $\frac{58}{(1.2 \times 14)}$

**Q5.** Write in standard form

(a) 20000

(b) 53400000

(c) 0.0085

(d) 0.00000193

**Q6.** Write in full

(a)  $3.2 \times 10^{-4}$

(b)  $8 \times 10^3$

(c)  $4.98 \times 10^6$

(d)  $5.36 \times 10^{-5}$

**S3 General Homework**  
**Shape & Space**

Name

Class

Mark

**Q1.** Fill in the missing angles in the diagrams below.

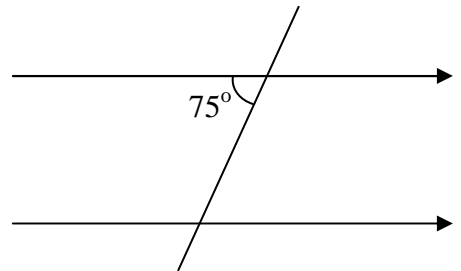
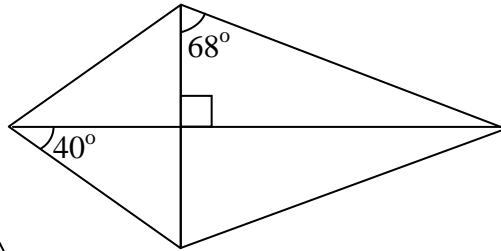
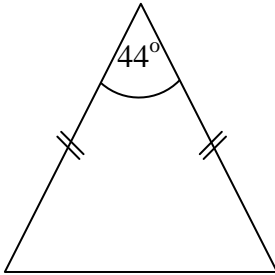

**Q2.** Complete the diagram so that the dotted lines are lines of symmetry.

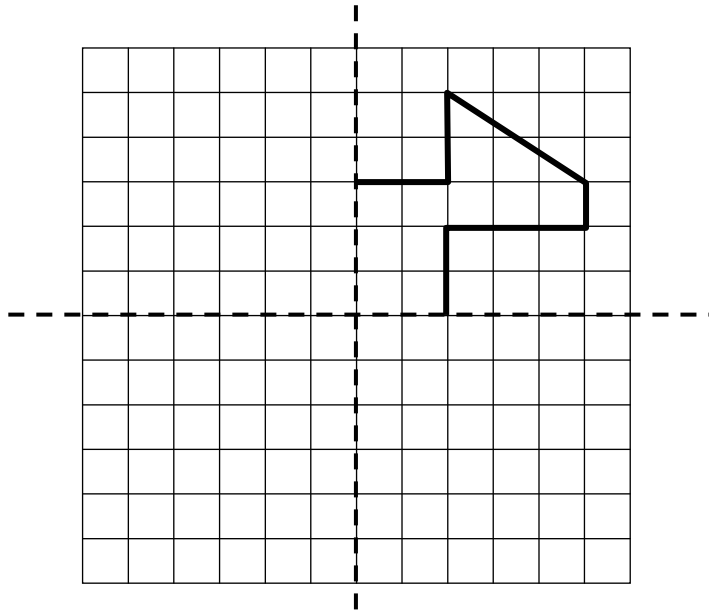

**Q3. (a)** Plot the points A(2, 1), B (8, 1) and C (8, 5).

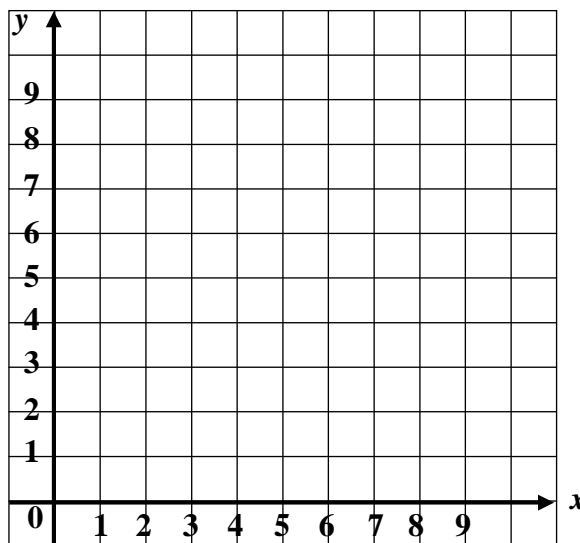

**(b)** Plot a fourth point D so that ABCD is a rectangle.

**(c)** Write down the coordinates of D.

**Q4.** Write down the name of each of these solids.

(a)

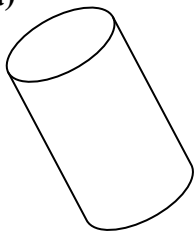

(b)

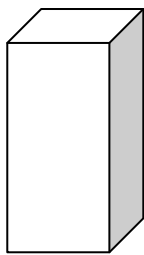

(c)

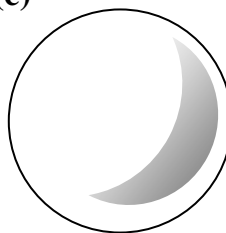

(d)

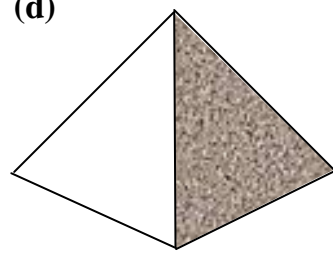

**Q5.**

By dividing the pentagon into triangles. or otherwise, find the size of angle ABC.

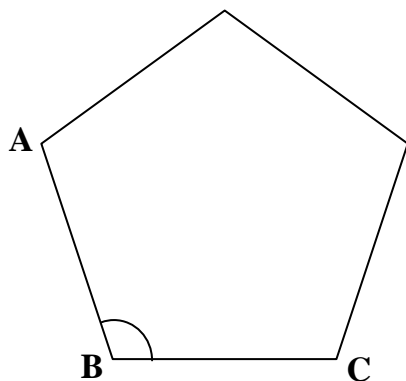

**Q6.** Find the surface area of this cuboid.

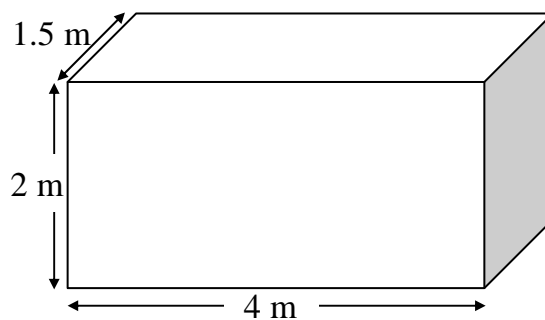

**S3 General Homework**  
**Numbers Review 1**

Name

Class

Mark

- Q1.** Martin is reading a book with 200 pages. There are 360 words on each page.  
How many words are there in total?

- Q2.** Two bunches of grapes are weighed in grams. The weights are shown below.



249g



318g

Find

**(a)** the total weight of the 2 bunches

**(b)** the difference in their weights

- Q3.** Calculate

**(a)**  $3.5 + 2.9$

**(b)**  $8.57 - 1.68$

**(c)**  $6.7 \times 8$

**(d)**  $7.56 \div 7$

- Q4.** Calculate

**(a)** 40% of £210

**(b)**  $\frac{3}{4}$  of 64

**(c)** 25% of 180g

**Q5.** Complete this table

$\frac{1}{5}$			$\frac{9}{10}$		
	0.7			0.25	
		12%			48%

**Q6.** Bookworms Bookstore reduce the prices of their books by  $33\frac{1}{3}\%$ .  
How much would you pay for a book that was originally priced at £18?

**Q7.** How many days are there in

**(a)** a fortnight

**(b)** 9 weeks

**(c)** 40 weeks?

**Q8.** How many hours and minutes between

**(a)** 2.30 pm and 5.45 pm

**(b)** 10.15 am and 3.10 pm

**Q9.** The temperature in Aberdeen one morning is  $-2^{\circ}\text{C}$ . During the day the temperature rises by 9 degrees. What is the temperature now?

**Q10.** A coach leaves Milton Keynes at 1050 and arrives in Hamilton at 1745.  
How long does the journey take?

**S3 General Homework**  
**Money Matters 1**

Name

Class

Mark

**Q1.** A shop assistant receives a gross weekly wage of £146.15 for a 37 hour week.  
What is the hourly rate ?

**Q2.** Peter works as a plumber. He gets paid £4.20 per hour plus overtime.  
Overtime is paid at time-and-a-half.

**(a)** How much would he earn for

**(i)** a 7-hour day?

**(ii)** a 35-hour week?

**(b)** What would he earn for

**(i)** 1 hour overtime?

**(ii)** 8 hours overtime?

**Q3.** VAT is charged at 17.5%. How much VAT would be paid on a music system costing £99.90 before VAT?  
Round your answer to the nearest 1p.

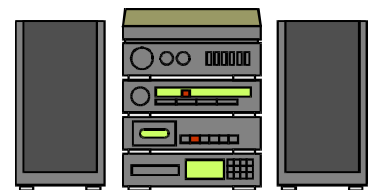

- Q4.** A mail order company sells a sofa for £469.95. It offers Hire Purchase terms of deposit of £69.95 and 24 monthly payments of £21.50  
 Calculate (a) the total HP cost ?  
 (b) how much you save by paying cash ?

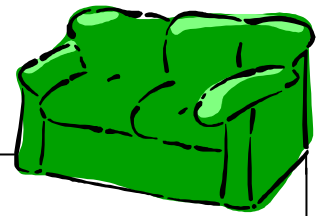

(a)

(b)

- Q5.** The White Horse Building Society pays interest of 4% per annum on savings. How much interest will Sheila receive on savings of £270 after  
 (a) 1 year? (b) 8 months?

(a)

(b)

- Q6.** Complete this electricity bill

Northern Electricity Company			
		Charges	Amount Due (£)
Present	Previous		
29334	28202	<input type="text"/> units @ 8.65p per unit	
		Standing charge	12.50
Electricity Electricity		Sub-Total	
		VAT	
		Total Due	



**S3 General Homework**  
**Similar Shapes**

Name

Class

Mark

**Q1.** Enlarge or reduce these shapes by the scale factor given.

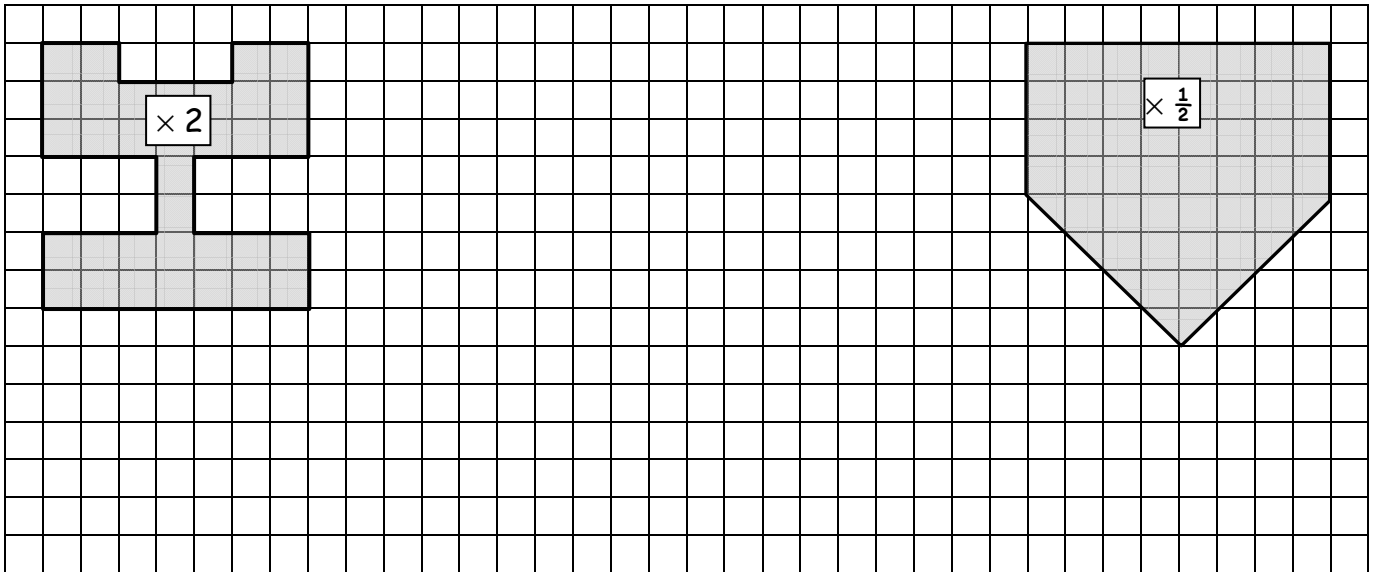

**Q2.** On a plan 1 centimetre represents 12 metres. How many metres does 7 cm represent?

**Q3.** A model tower was made to a scale of 1 cm to 50 m. If the model's height is 3 cm, what is the height of the real tower?

**Q4.** On a map the scale is 1:200000. What distance, in kilometres, is represented by 5 cm on the map?

Q5.

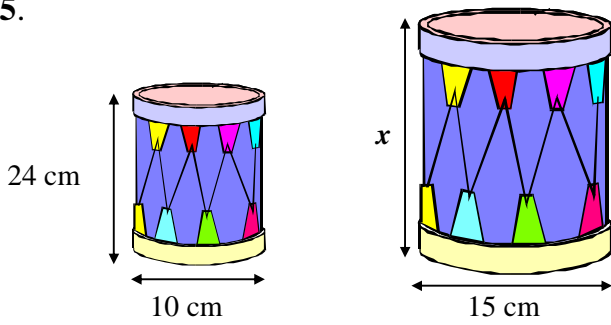

These toy drums are similar. The diameter of the small drum is 10 cm. and the diameter of the large drum is 15 cm.

If the height of the small drum is 24 cm, what is the height,  $x$ , of the large drum ?

Q6. These two triangles are similar.

Calculate the length of the side marked  $x$ .

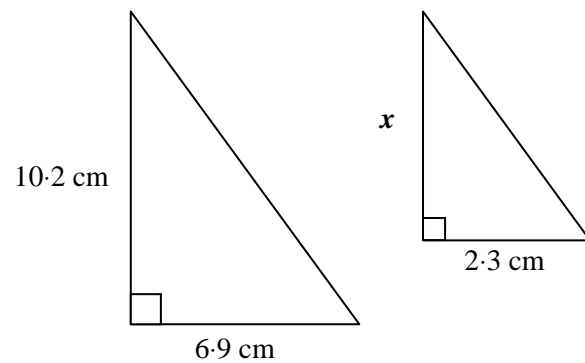

**S3 General Homework**  
**Letters & Numbers Review 1**

Name

Class

Mark

**Q1.** Simplify:

(a)  $x + x + x + x + x$

(b)  $k + 3k + 4k$

(c)  $12m + 9m - 2m$

(d)  $4p + 2q + 3q$

(e)  $5x - 5x$

(f)  $3a + 5b - b - 2a$

**Q2.**

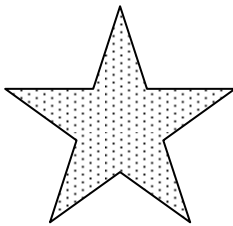

How many points on 1 star

7 stars

$k$  stars?

**Q3.** If  $x = 5$  and  $y = 3$ , find the value of

(a)  $x + y$

(b)  $2x - 4$

(c)  $x^2 + 6y$

**Q4.** Write without brackets

(a)  $2(x + 5)$

(b)  $7(b - 9)$

(c)  $8(6 + w)$

**Q5.** Calculate:

(a)  $3 + (-2)$

(b)  $-5 + 8$

(c)  $-4 - 6$

(d)  $-12 + 5$

**Q6.** Solve these equations:

(a)  $x + 5 = 3$

(b)  $y - 4 = 1$

(c)  $z + 3 = -2$

**S3 General Homework**  
**Speed, Distance, Time**

Name

Class

Mark

- Q1.** Stephen is doing a sponsored walk covering a distance of 20 km.  
He can walk at an average speed of 5 km/h.  
How long will it take him to finish the walk?

- Q2.** An aeroplane flies at 420 miles per hour for 45 minutes.  
Calculate the distance it has travelled.



- Q3.** A bus leaves the bus station in Glasgow at 9.45 am.  
It arrives in Edinburgh, a distance of 51 miles, at 11.15 am.  
Calculate its average speed.



- Q4.** The diagram shows Mr Jones' journey to a business meeting.  
He leaves his house at 10 am.  
He stops for a break then continues on his journey. He travels a total of 70 miles.

- (a) What does one square on the horizontal axis stand for?

- (b) What does one square on the vertical axis stand for?

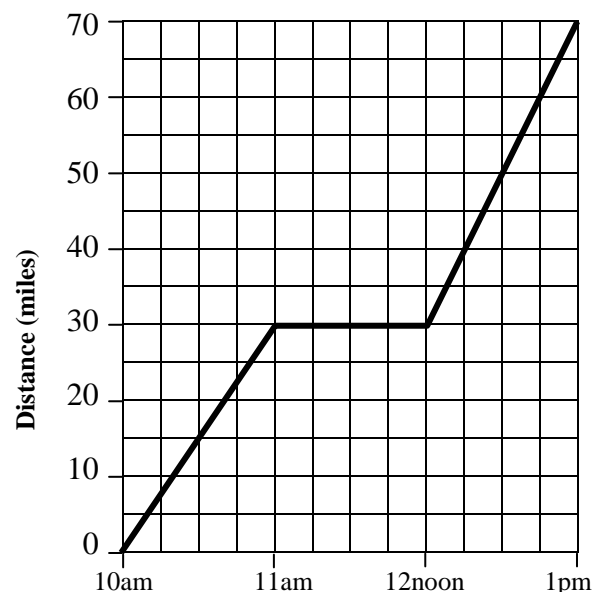

(c) How far does he travel in the first part of the journey?

(d) Calculate his speed for the first part of the journey.

(e) How long does he take a break for?

(f) Was he travelling faster or slower in the second part of the journey?

(g) Calculate his average speed for the whole journey. (from when he leaves his house until he arrives at his meeting)

**Q5.** A coach leaves London and travels to Aberdeen, a distance of 750 km, at an average speed of 80 km/h. If the coach leaves London at 0815, what time will it arrive in Aberdeen?

# S3 General Homework Brackets

Name

Class

Mark

**Q1.** Multiply out the brackets

(a)  $3(x + 5)$

(b)  $7(y + 8)$

(c)  $4(a - 9)$

(d)  $9(b - 5)$

**Q2.** Multiply out the brackets

(a)  $x(x + 2)$

(b)  $a(b + c)$

(c)  $m(8 - m)$

(d)  $y(b - 5)$

**Q3.** Multiply out the brackets

(a)  $5(3x + 4)$

(b)  $6(2b + c)$

(c)  $10(4 - 5d)$

(d)  $8(7y - 6)$

**Q4.** Multiply out the brackets and simplify

(a)  $3(x + 7) + 2x$

(b)  $5(2y + 3) - 6y$

(c)  $7(s - 4) + 13$

**Q5.** Factorise

(a)  $12b + 8$

(b)  $x^2 + 5x$

(c)  $ab + ac$

(d)  $6b - 9c$

(e)  $2y^2 - 4y$

(f)  $4ab^2 - 6abc$

**S3 General Homework**  
**Brackets & Equations**

Name

Class

Mark

**Q1.** Solve these equations

(a)  $3x + 5 = 29$

(b)  $4a - 9 = 7$

**Q2.** Solve these equations by first multiplying out the brackets

(a)  $5(x + 2) = 25$

(b)  $10(d - 8) = 20$

**Q3.** Solve these equations by first multiplying out the brackets

(a)  $3(2x - 4) = 6$

(b)  $4(5x + 2) = 108$

**Q4.** Solve these equations

**(a)**  $4 + 3(x - 3) = 13$

An empty rectangular box with a black border, intended for the student to show their work for solving equation (a).

**(b)**  $3 - 2(4 - x) = 11$

An empty rectangular box with a black border, intended for the student to show their work for solving equation (b).

**Q5.** Solve these equations

**(a)**  $4(x - 3) = 2(x + 1)$

An empty rectangular box with a black border, intended for the student to show their work for solving equation (a).

**(b)**  $7(x + 1) = 2(x + 11)$

An empty rectangular box with a black border, intended for the student to show their work for solving equation (b).



**S3 General Homework**  
**Statistics Review**

Name

Class

Mark

**Q1.** The pupils in a class were asked their favourite country for going on holiday.  
 The results are shown in the pie chart

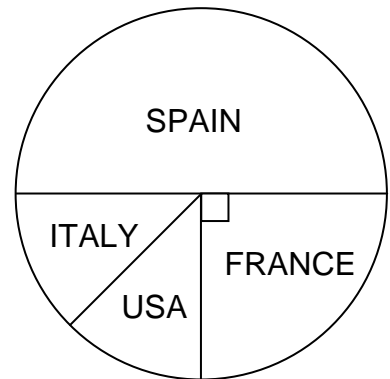

(a) List the countries in order, most popular first?

(b) What *fraction* of the pupils preferred

(i) Spain

(ii) France

(iii) Italy

(iv) USA ?

**Q2.** The table shows the numbers of different types of books borrowed from a school library in one day.

Type of Book	Sport	Crime	Horror	Romance	Sci-Fi
Number	6	14	12	22	16

Show this information on a bar chart.

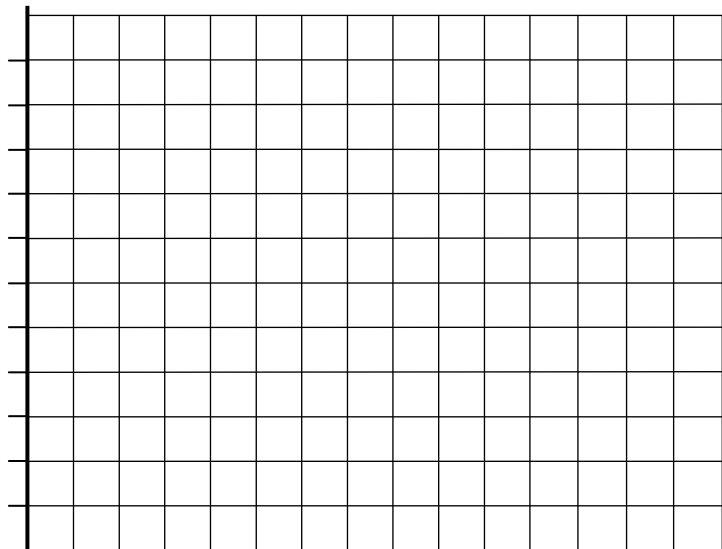

**Q3.** The ages of the players in a local football team are given below :

19    23    30    24    19    25    31    27    28    30    19

Calculate the mean, median, mode and range .

**Q4.** Simon's temperature was measured every 2 hours over a 24-hour period. The readings are shown in the line graph below.

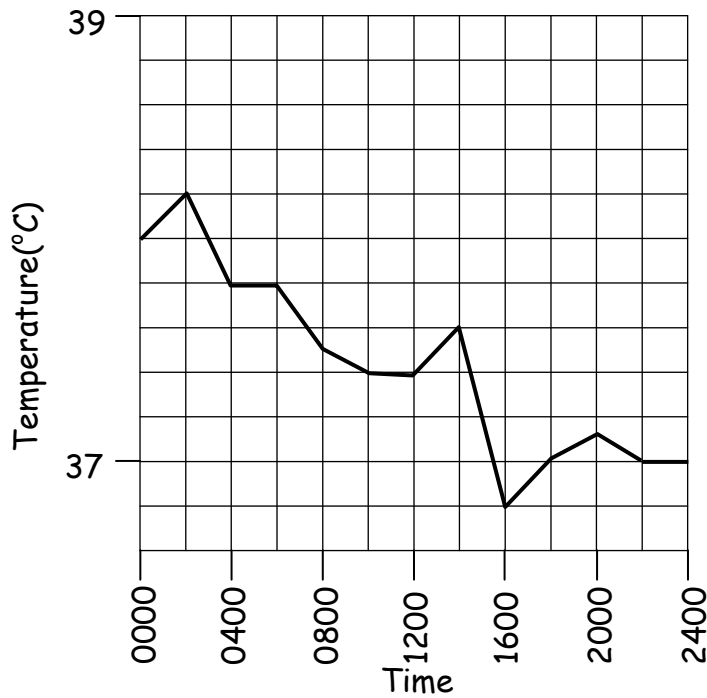

(a) What was the highest temperature?

(b) When was this?

(c) Between what two times did the temperature drop most?

(d) When did his temperature finally return to normal (37°C)?

# S3 General Homework Statistics 1

Name

Class

Mark

**Q1.** An express delivery firm charges by weight ( $W$ ) and delivery time.

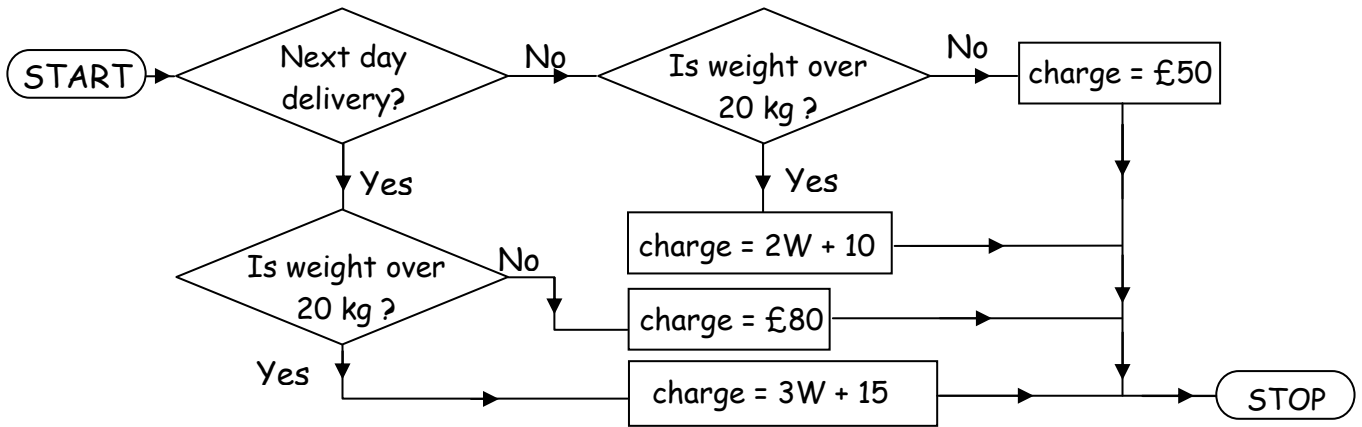

Calculate the cost of a parcel weighing

(a) 15 kg (next day)

(b) 32 kg

(c) 26 kg (next day)

**Q2.** A small firm employs 10 people. The salaries of the employees are as follows :

£40 000      £18000      £15000      £9000      £15000,  
£15000      £13000      £15000      £15000      £15000.

(a) Calculate the mean, median and mode.

(b) Which of the three measures best describes the *average* salary in the company?

# S3 General Homework

## Pythagoras' Theorem

Name

Class

Mark

**Q1.** Find the length of  $x$  in each of the triangles below.

(a)

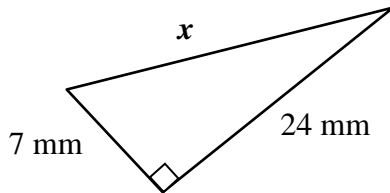

(b)

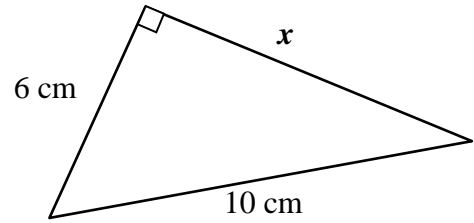

**Q2.** A rectangular jigsaw measures 65 cm by 52 cm.  
What length is its diagonal?

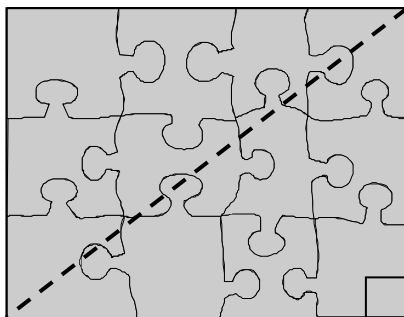

65 cm

52 cm

**Q3.**

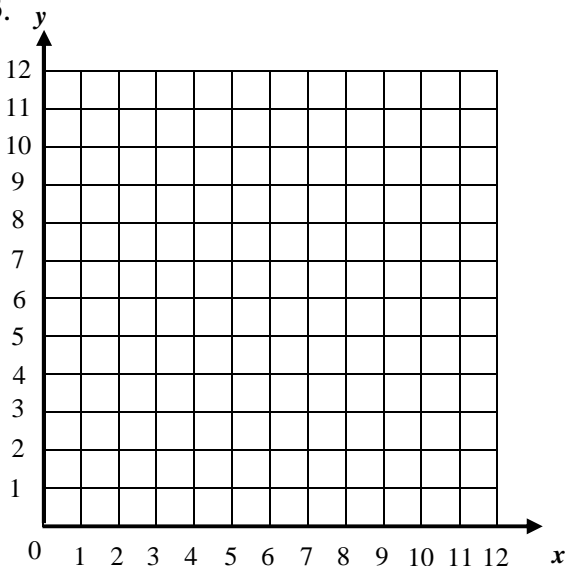

- (a) Plot the points A(3, 1) and B(10, 10)
- (b) Make a right-angled triangle and mark in the lengths of the sides.
- (c) Calculate the length of AB, to 1 dp.

**S3 General Homework**  
**Number Review 2**

Name

Class

Mark

- Q1.** Amanda collects music magazines which are printed monthly. Each magazine is 5 millimetres thick. A shelf, 0.4 metres long, is filled with these magazines. How many magazines are on the shelf?

**Q2.**

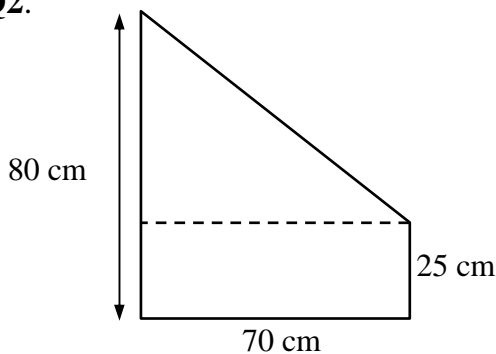

Calculate the area of the shape shown in the diagram.

- Q3.** The drum shown has a diameter of 24 cm.

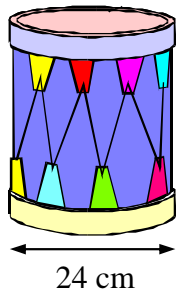

Calculate **(a)** its circumference

**(b)** the area of the top surface

- Q4.** Chris buys a 3-litre bottle of cola for when his friends come to visit. He has glasses which hold 200 ml. How many glasses of cola will he get out of one bottle?

**Q5.** Brian gets a fish tank for his birthday.  
It measures 30 cm by 60cm by 30 cm.

(a) Calculate the volume of the **fish tank**  
in litres.

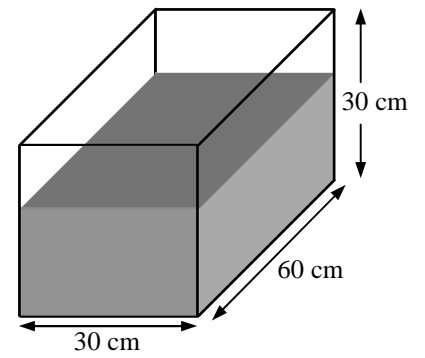

(b) If Brian pours 36 litres of water into the empty tank, what will be the **depth** of the  
water in the tank?

**Q6.** It costs £588 to hire scaffolding for 42 days. How much would it cost to hire the same  
scaffolding for 36 days at the same rate per day ?

**Q7.** Michael & David win £1600 on the lottery and are going to split it in the ratio 3:5.  
How much does each get?

# S3 General Homework

## Area & Volume 1

Name

Class

Mark

**Q1.** Find the area of each shape shown below. *Show all your working.*

(a)

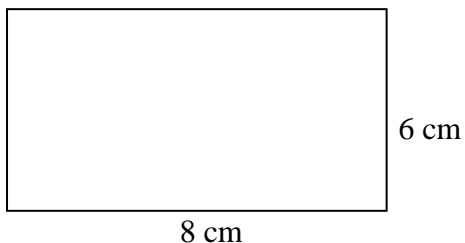

(a)

(b)

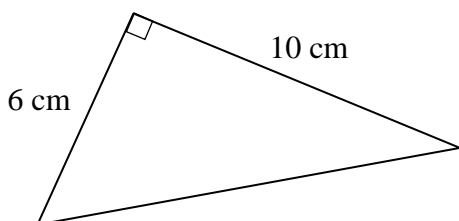

(b)

(c)

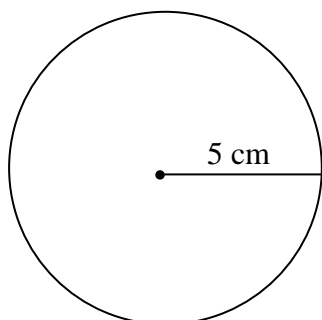

(c)

**Q2.** Calculate the areas of the quadrilaterals shown below.

(a)

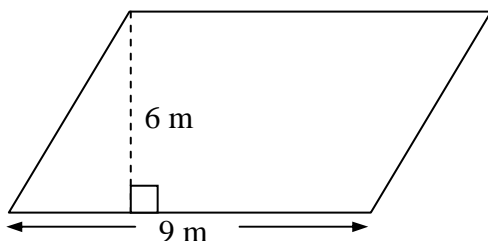

(a)

(b)

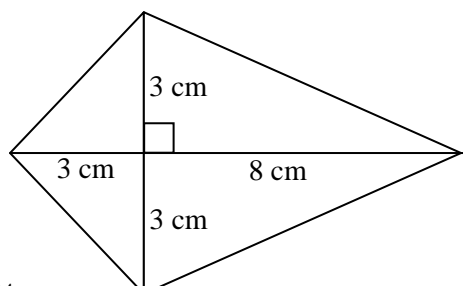

(b)

**Q3.** Calculate the volumes of the following solid shapes.

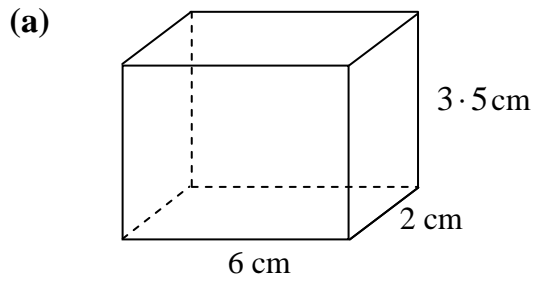

(a)

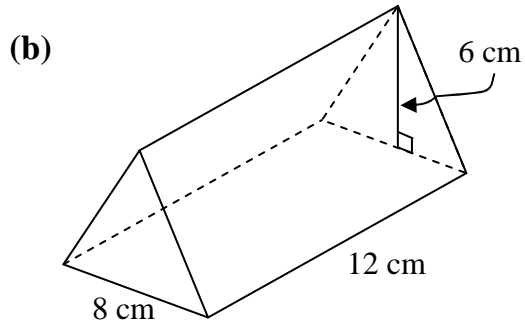

(b)

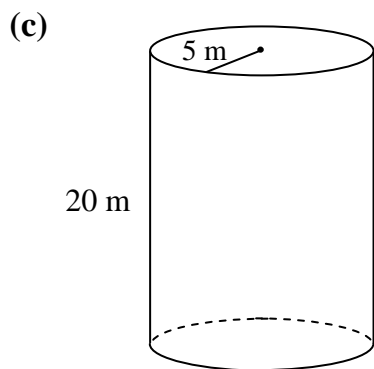

(c)

**Q4.** Calculate the volume of this solid shape.

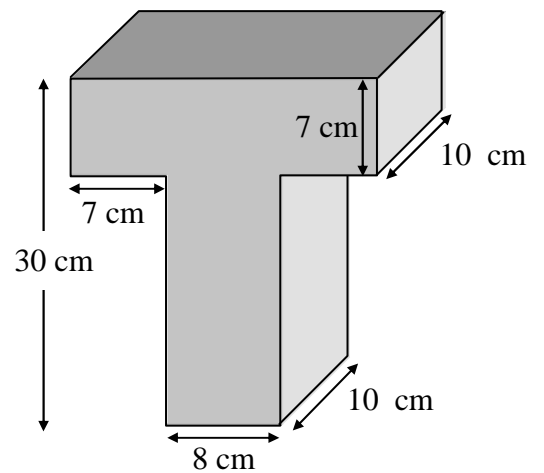



**S3 General Homework**  
**Area & Volume 2**

Name

Class

Mark

- Q1.** A rectangular tank is 1.5 m long, 30 cm broad and 20 cm high.  
 How many **litres** of water can it hold?

- Q2.** A window is in the shape of a rectangle, 4m by 2m with a semicircle of diameter 4m on top.  
 Find the area of glass in the window.

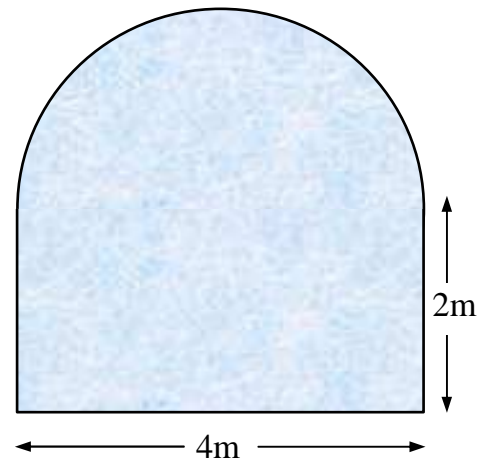

- Q3. (a)** A box of chocolates is in the shape of a triangular prism.  
 Calculate its volume.

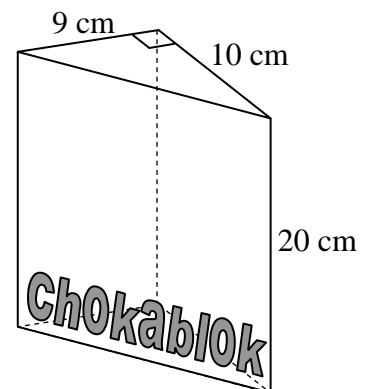

- (b)** The box contains 63 chocolates each with a volume of  $4 \text{ cm}^3$ .  
 What **percentage** of the volume of the box is unused?

**Q4.** A cylindrical tin holds a litre of liquid and has a diameter of 7 cm. Calculate its height.

**Q5.**

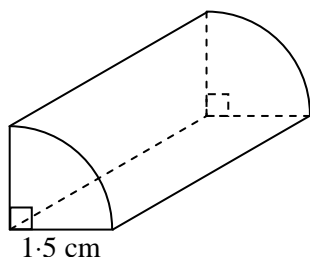

The end of the wooden mouldings used to make a photograph frame is in the shape of a quarter-circle. If a total length of 70 cm of mouldings is required for a frame, find the volume of wood used.

**Q6.** Mrs Gamp is going to cover the **curved surface** of a cylindrical umbrella stand with waterproof fabric. The radius is 10 cm and the height is 60 cm.

Calculate the area of material required.

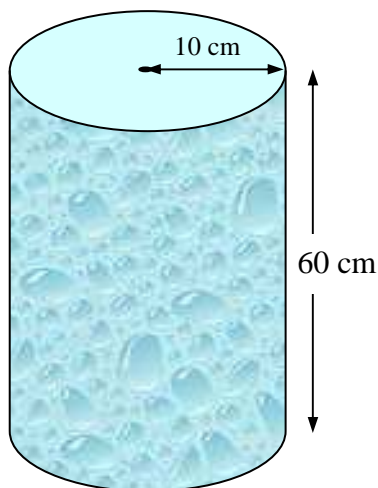

**S3 General Homework**  
**Money Matters 2**

Name

Class

Mark

**Q1.** Tony is paid a basic monthly salary of £450 plus commission of 12% of his total monthly sales.

Employee Number 0129	Employee Name <b>Tony Paterson</b>	Tax Code <b>342H</b>	Month 2
Basic Pay 450.00	Overtime -	Commission	Gross Pay
Income Tax 243.70	Pension	National Insurance 91.80	Total Deductions
			Net Pay

- (a) Calculate his commission in a month where his sales total £9000. Write this in his pay-slip.
- (b) Calculate his gross pay and write it in the pay-slip.
- (c) Tony pays 8% of his gross pay into a pension fund. He also pays £91.80 National Insurance and £243.70 Income Tax this month. Calculate his net pay for this month and complete the pay slip.

**Q2.** Mark has an income of £23500 and allowances of £5300.

- (a) Calculate Mark's taxable income.

- (b) Use the table on the right to calculate how much tax Mark will pay in a year.

Taxable Income	Rate of tax
Lower rate (£1-£4300)	20%
Basic rate (£4301 - £22800)	23%
Higher rate (over £22800)	40%

**Q3.** Soraya is travelling to Europe and changes £245 into Euros at the rate of £1 = €1.64

**(a)** How many Euros does she receive ?

**(b)** She spends 300 Euros. How much does she have left ?

**(c)** When she returns she exchanges her Euros for British money. How much will she get, to the nearest penny ?

**Q4.** Kevin earns £215 a week and pays 6% in superannuation.  
How much superannuation will he pay?

**Q5.** Calum wants to insure his life for £18000. The annual premium is £9.84 per £1000.  
How much will he pay

**(a)** per year

**(b)** per month

**S3 General Homework**  
**Letters & Numbers Review 2**

Name

Class

Mark

**Q1.** Solve these equations:

(a)  $2x + 1 = 19$

(b)  $5y - 1 = 49$

**Q2.** Solve :

(a)  $7x + 5 = 3x + 21$

(b)  $15y - 9 = 7y - 1$

**Q3.** Write down a formula for the perimeter of this shape.

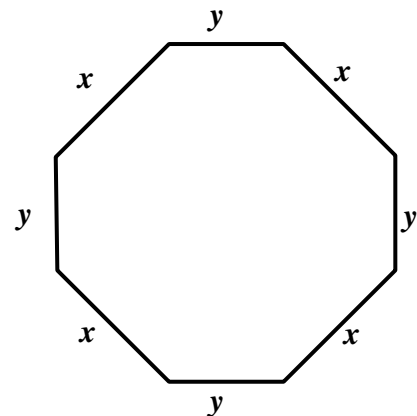

**Q4.** Find a formula for the  $n$ th term of this sequence.

5, 13, 21, 29, 37, . . . .

**Q5.** Solve these equations

**(a)**  $7(x - 1) = 21$

**(b)**  $9(x + 2) = 45$

**Q6.**

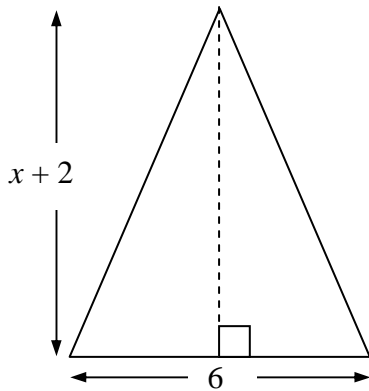

**(a)** Write down an expression for the area of this triangle.

**(b)** The base and height of the triangle are in centimetres.  
If the area of the triangle is  $24 \text{ cm}^2$ , form an equation and solve it to find  $x$ .

**Q7.** Write down the solutions of these inequations from the set  
 $\{-4, -3, -2, -1, 0, 1, 2, 3, 4\}$

**(a)**  $x \geq -2$

**(b)**  $y < -1$

**(c)**  $z > 3$

# S3 General Homework Formulae

Name

Class

Mark

**Q1.**  $A = 3b - 2c$ . Find the value of  $A$  when

(a)  $b = 4, c = 5$

(b)  $b = 6, c = 9$

(c)  $b = 28, c = 11$

(d)  $b = 3, c = -2$





**Q2.** Find a formula for the  $n$ th term for each of the sequences below.

(a) 4, 7, 10, 13, ...

(b) 3, 8, 13, 18, ...

(c) 25, 29, 33, 37, ...



**Q3.**

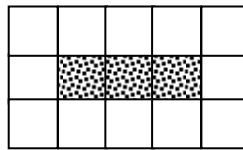
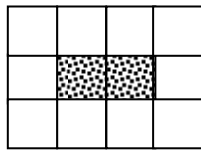
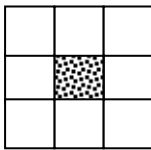

The diagrams on the left show tiling patterns for doorsteps.

(a) Draw the 4th pattern in the sequence

(b) Complete the table below.

Number of coloured tiles, $C$	1	2	3	4	5	6
Number of white tiles, $W$						

(c) Write down the formula for finding the number of white tiles if you know the number of coloured tiles.

$W =$

(d) How many white tiles would you need if you had 13 coloured tiles?

(e) How many coloured tiles would you need if you had 24 white tiles?

**S3 General Homework**  
**Statistics & Probability**

Name

Class

Mark

**Q1.** The graph shows the time taken for a journey at different speeds.

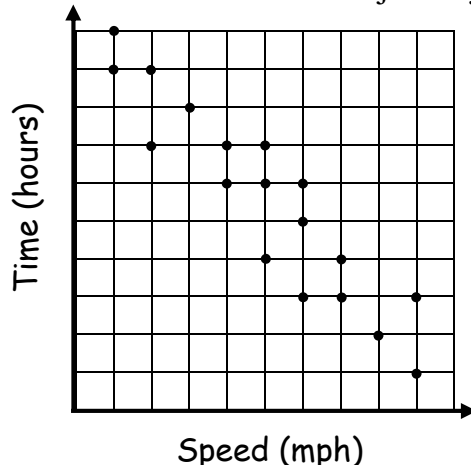

Describe the correlation.

**Q2.** The stem and leaf chart below shows the amounts of money spent by customers in a shop :

2	2	3	3						
3	0	1	1	6	7				
4	0	1	3	3	8	9			
5	0	0	1	2	4	5	6	9	
6	0	0	1	1	7				
7	1	3	3						
8	0	6	8						

n = 33     2 | 1 represents 21

(a) Write down     **i.** the median     **ii.** the range

(b) What is the probability that a customer chosen at random has spent less than 30 pence?



**Q3.** The table below shows the weights in kilograms of group of boys.  
Show this information on a stem and leaf chart.

39	42	48	38	51	44
42	51	53	42	47	39
38	45	43	51	47	57
42	44	38	43	48	50
42	41	52	49	39	46

**Q4.** Darren and his friend are playing with a pack of cards which is missing the Ace of Spades and the King of Hearts.

What is the probability that the first card dealt is

(a) an Ace?

(b) a black card?

(c) a Queen?

(d) the 4 of clubs?

**S3 General Homework**  
**Shape & Space Review**

Name

Class

Mark

**Q1.** Name, and calculate the sizes of, the angles marked \*

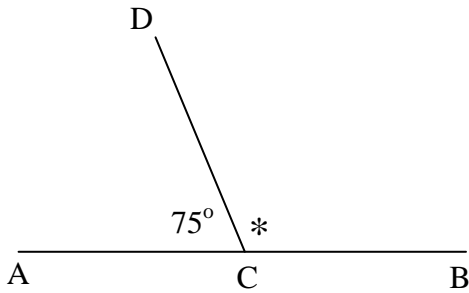

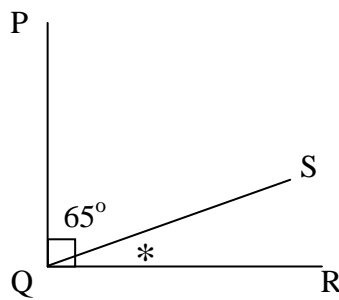

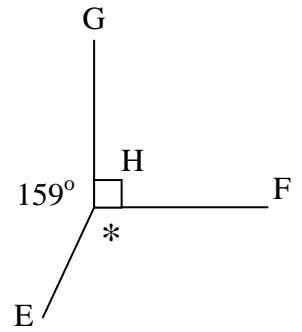

**Q2. (a)** From the diagram below, name

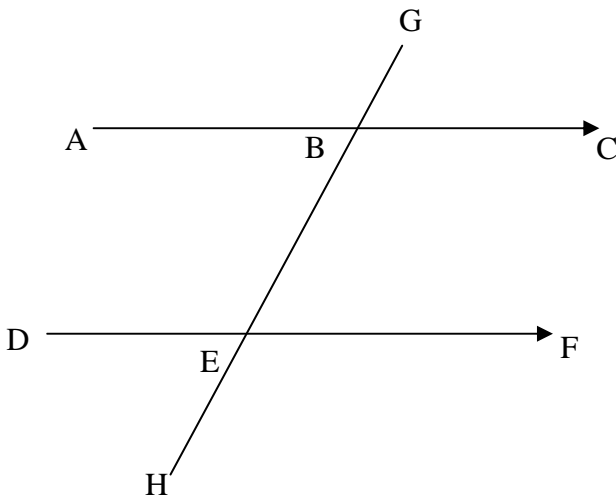

**i.** the supplement of  $\angle ABG$

**ii.** the angle vertically opposite to  $\angle DEH$

**iii.** the angle corresponding to  $\angle EBC$

**iv.** the angle alternate to  $\angle FEB$

**(b)** If  $\angle ABG = 120^\circ$ , calculate the size of

**i.**  $\angle ABE$

**ii.**  $\angle DEH$

**iii.**  $\angle BEF$

**iv.**  $\angle GBC$

**Q3.** Find the area of this triangle:

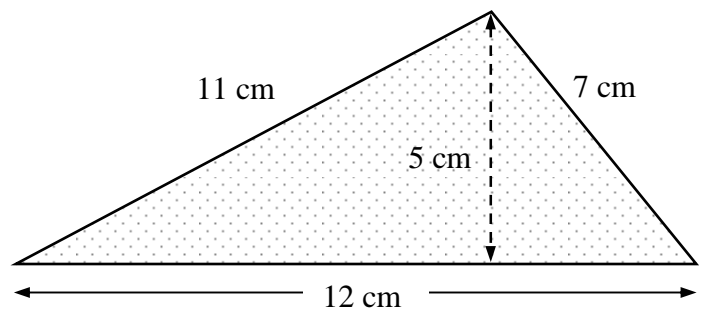

**Q4.** From the rectangle shown, write down (a) the length of **i** AB **ii.** BC

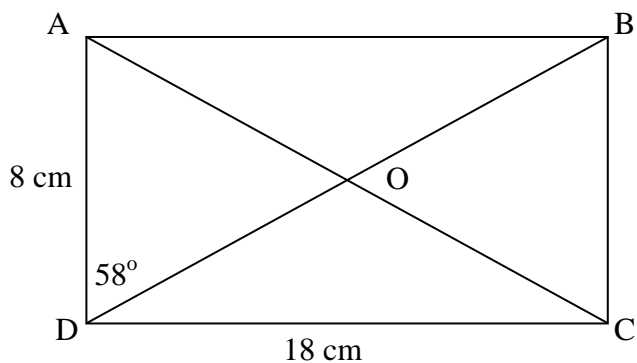

--	--

(b) the size of angle

i. $\angle AOD$	ii. $\angle DOC$	iii. $\angle ODC$
-----------------	------------------	-------------------

**Q5.** Complete the diagrams so that each dotted line is an axis of symmetry.

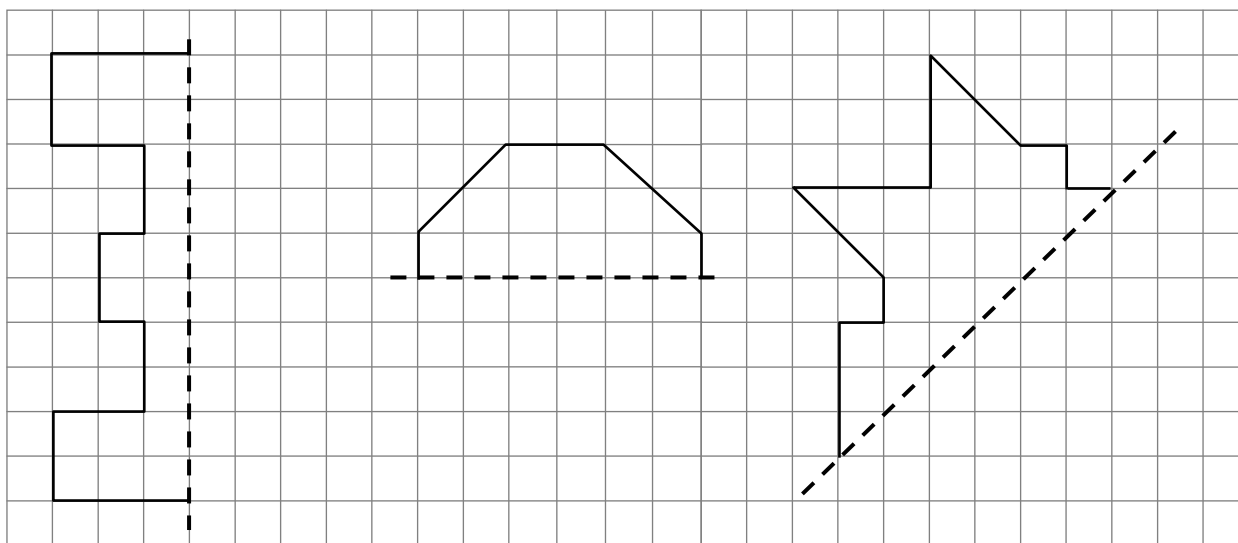

**Q6.** Write down the sizes of the angles marked with the letters a – h.

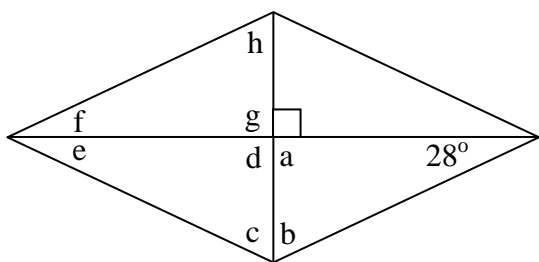

a	b	c	d
e	f	g	h

**Q7.** Calculate the surface area of the carton shown.

