

Mathematics
Mathematics 1
(Int 1)

August 1998

HIGHER STILL

Mathematics

Mathematics 1
Intermediate 1

Support Materials



MATHEMATICS 1 (INT 1) STAFF NOTES

INTRODUCTION

These support materials for Mathematics were developed as part of the Higher Still Development Programme in response to needs identified at needs analysis meetings and national seminars.

Advice on learning and teaching may be found in *Achievement for All* (SOEID 1996), *Effective Learning and Teaching in Mathematics* (SOEID 1993) and in the Mathematics Subject Guide.

This support package provides student material to cover the content of Mathematics 1 of the course at Intermediate 1. The depth of treatment is therefore more than is required to demonstrate competence in the unit assessment; that is, it goes beyond minimum grade C. The content is set out in the landscape pages of the content for Mathematics 1 (Int 1) in the Arrangements document where the requirements of the unit Mathematics 1 (Int 1) are also stated. Students may have met much of this work previously though possibly not in the depth with which it is treated here. Some of it will be new, especially for those students who have followed a strictly Foundation course at Standard Grade.

The material is designed to be directed by the teacher/lecturer who will decide on the ways of introducing topics and on the use of the exercises for consolidation and for formative assessment. The use of calculators will be necessary for much of the work, and students should be encouraged to set down all working, and where appropriate, use mental calculations.

An attempt has been made to have the ‘easy’ questions at the start of each exercise leading to more testing questions towards the end of each exercise. While students may tackle most of the questions individually there are opportunities for collaborative working. Staff will wish to discuss points raised with individuals, groups and the whole class.

The specimen assessment questions at the end of the package are **not** intended to be only at minimum grade C. The National Assessment Bank packages for Mathematics 1 (Int 1) contain questions which meet the requirements of this unit.

This package gives opportunities to practise core skills particularly the components of the Numeracy core skills, Using Number and Using Graphical Information, and Problem Solving. Information on the core skills embedded in the unit, Mathematics 1 (Int 1) and in the Intermediate 1 course is given in the final version of the Arrangements document. General advice and details of the Core Skills Framework can be found in the Core Skills Manual (HSDU June 1998).

Brief notes of advice on the teaching of each topic are given.

Format of the Student Materials

- Exercises on Basic Calculations
Check-up for Basic Calculations
- Exercises on Basic Geometric Properties
Check-up for Basic Geometric Properties
- Exercises on Expressions and Formulae
Check-up for Expressions and Formulae
- Exercises on Calculations in Everyday Contexts
Check-up for Calculations in Everyday Contexts
- Specimen Assessment Questions
- Answers for all exercises.

BASIC CALCULATIONS

A. Find a Percentage of a Quantity

Give students an explanation of, followed by a discussion about 'Percentages'.

Part 1 - Show how to express a percentage as a decimal.

Example 1. $32\% = \frac{32}{100} = 0.32$ Example 2. Find $12.5\% = \frac{12.5}{100} = 0.125$

State that special percentage cases should be expressed as vulgar fractions and learned:

e.g. $33\frac{1}{3}\% = \frac{1}{3}$ and $66\frac{2}{3}\% = \frac{2}{3}$

Exercise 1 Q1 and Q2 may now be attempted.

Part 2 - Show how to find a percentage of a quantity.

Example 1. Find 30% of £82

Ans: 30% of £82
 $= \frac{30}{100} \times £82$ ($30 \div 100 \times £82$)
 $= £24.60$ (by calculator)

Example 2. Find 2.5% of £20

Ans: 2.5% of £20
 $= \frac{2.5}{100} \times £20$ ($2.5 \div 100 \times £20$)
 $= £0.50$ (by calculator)

Example 3. Find 17.5% of £40

Ans: 17.5% of £40
 $= \frac{17.5}{100} \times £40$ ($17.5 \div 100 \times £40$)
 $= £7$ (by calculator)

Example 4. 8% of a first year class of 25 are girls.
How many are: (a) girls (b) boys?

Ans: (a) Girls 8% of 25
 $= \frac{8}{100} \times 25$ ($8 \div 100 \times 25$)
 $= 2$ (by calculator) (b) Boys $25 - 2 = 23$

Note: students could be shown how to use the '%' button on a calculator, if preferred.

Complete Exercise 1 by attempting Q3 - Q12.

The following terms should be explained:
Interest Rates, Per Annum.

Example 1. Calculate the interest on £120 for 1 year at 3% per annum and say how much is now in the account.

$$\begin{aligned}\text{Ans: Interest} &= 3\% \text{ of } \pounds 120 \\ &= \frac{3}{100} \times \pounds 120 \quad (3 \div 100 \times \pounds 120) \\ &= \pounds 3.60 \quad (\text{by calculator}) \\ \text{Now in account} &= \pounds 120 + \pounds 3.60 \\ &= \underline{\pounds 123.60}\end{aligned}$$

Example 2. Calculate the interest for 3 months on £200 at 5% per annum.

$$\begin{aligned}\text{Ans: Interest for 1 year} &= 5\% \text{ of } \pounds 200 \\ &= \frac{5}{100} \times \pounds 200 \quad (5 \div 100 \times \pounds 200) \\ &= \pounds 10 \quad (\text{by calculator}) \\ \text{Interest for 3 months} &= \frac{1}{4} \text{ of } \pounds 10 \quad (3 \text{ months} = \frac{1}{4} \text{ of a year}) \\ &= \underline{\pounds 2.50}\end{aligned}$$

Exercise 2 may now be attempted.

The following terms should be explained:
Percentage Decrease and Percentage Increase, Sale, Discount, VAT.

Example 1. A suit is normally priced at £180, but in a sale, a 12% discount is being offered.

- (a) How much money should I expect to get off the suit?
- (b) Find the sale price of the suit.

$$\begin{aligned}\text{Ans: (a) Discount} &= 12\% \text{ of } \pounds 180 \\ &= \frac{12}{100} \times \pounds 180 \quad (12 \div 100 \times \pounds 180) \\ &= \pounds 21.60 \quad (\text{by calculator}) \\ \text{(b) Sale Price} &= \pounds 180 - \pounds 21.60 \\ &= \underline{\pounds 158.40}\end{aligned}$$

Example 2. A delivery company put up all prices by $3\frac{1}{2}\%$.
What is the new cost of a job which originally cost £80?

$$\begin{aligned}\text{Ans: Increase} &= 3\frac{1}{2}\% \text{ of } \pounds 80 \\ &= \frac{3.5}{100} \times \pounds 80 \quad (3.5 \div 100 \times \pounds 80) \\ &= \pounds 2.80 \quad (\text{by calculator}) \\ \text{New Cost} &= \pounds 80 + \pounds 2.80 \\ &= \underline{\pounds 82.80}\end{aligned}$$

Exercise 3 may now be attempted.

B. Express one Quantity as a Percentage of Another

The students should be shown how to express a vulgar fraction as a percentage and how to express one quantity as a percentage of another.

e.g. $\frac{1}{2}$ expressed as a percentage is 50% since $\frac{1}{2} \times 100 = 50$ (%)

Example 1. Express $\frac{1}{8}$ as a percentage.

Ans: $\frac{1}{8} \times 100 = (1 \div 8 \times 100) = 12.5\%$ (by calculator)

Example 2. Express £8 as a percentage of £32

Ans: £8 out of a total of £32 is written $\frac{8}{32}$ (without the £ sign)
as a % = $\frac{8}{32} \times 100$ ($8 \div 32 \times 100$)
= 25%

Example 3. Of the 1250 pupils in a school, 425 are girls.

What percentage of the school population are: (a) girls (b) boys?

Ans: (a) % Girls = $\frac{425}{1250} \times 100$ ($425 \div 1250 \times 100$)
= 34%
(b) % Boys = $100\% - 34\% = \underline{66\%}$

Exercise 4 may now be attempted.

C. Rounding

The following should be demonstrated on the board.

Rounding to the nearest whole:

Examples 3.2 metres between 3 m and 4 m nearer 3 m	5.7 seconds between 5 s and 6 s nearer 6 s	7.5 ml between 7 ml and 8 ml half way.....round up to 8 ml
---	---	---

Rounding to the nearest ten:

Examples 43 metres between 40 m and 50 m nearer 40 m	429 seconds between 420 s and 430 s nearer 430 s	255 ml between 250 ml and 260 ml half way.....round up to 260 ml
---	---	---

Rounding to the nearest hundred:

Examples 431 metres between 400 m and 500 m nearer 400 m	579 seconds between 500 s and 600 s nearer 600 s	4550 ml between 4500 ml and 4600 ml half way.....round up to 4600 ml
---	---	---

Rounding to the nearest thousand:

Examples 7312 metres 6781 seconds 8500 ml
between 7000 m and 8000 m between 6000 s and 7000 s between 8000 ml and 9000 ml
nearer **7000 m** nearer **7000 s** half way.....round up to **9000 ml**

Exercise 5 may now be attempted.

Rounding to a number of decimal places – the following should be demonstrated on the board.

Rounding to one dec. pl.:

Examples 3.24 5.18 7.55
 between 3.2 and 3.3 between 5.1 and 5.2 between 7.5 and 7.6
 nearer **3.2** nearer **5.2** half way.....round up to **7.6**

Rounding to two dec. pl.:

Examples 6.241 5.117 3.515
 between 6.24 and 6.25 between 5.11 and 5.12 between 3.51 and 3.52
 nearer **6.24** nearer **5.12** half way.....round up to **3.52**

Rounding to three dec. pl.:

Examples 3.2714 5.1299 7.3505
 between 3.271 and 3.272 between 5.129 and 5.130 between 7.350 and 7.351
 nearer **3.271** nearer **5.130** EXPLAIN 0 half way.....round up to **7.351**

Exercise 6 may now be attempted

D. Direct Proportion

Explain Direct Proportion using the following examples:

‘The **more** you buy, the **more** it costs’ ‘The **less** fat you eat, the **less** weight you put on’

Ask students for more instances. Indicate also what would not be direct proportion.

Example 1.

The cost of one apple is 7p. What do eight cost?

(This is a simple example where the cost of 1 given and the student need only multiply)

Ans: APPLES COST (unknown quantity on R.H.S.)
 1 7p
 8 7p × 8 = 56p

Example 2.

I hire a chain saw for 4 days. It costs me £9.

What will it cost my next door neighbour to hire it for 7 days?

(This is a harder example where the cost of 1 not given. The student has to find cost of 1, then multiply.)

Ans:	DAYS	COST	(unknown quantity on R.H.S.)
	4	£9	
	1	$£9 \div 4 = £2.25$	
	7	$£2.25 \times 7 = \underline{£15.75}$	(or \times by $7/4$ instead)

Example 3.

A building 20 feet high casts an 8 foot shadow.

What length of shadow would be cast at the same time by a 6 foot tree?

(This is again a harder example since the length of 1 not given. The student has to find the length of 1, then multiply)

Ans:	LENGTH	SHADOW LENGTH	(unknown quantity on R.H.S.)
	20 ft	8 ft.	
	1 ft	$8 \div 20 = 0.4$	(by calculator)
	6 ft	$0.4 \times 6 = \underline{2.4 \text{ ft}}$	or \times by $6/20$ in the first instance)

Exercise 7 may now be attempted Then Checkup for Basic Calculations

BASIC GEOMETRIC PROPERTIES

A. Find the Area of a Simple Composite Shape

Triangles and Quadrilaterals

Go over the formulae for the areas of triangles and quadrilaterals with the students.

Examples

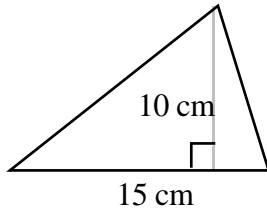

$$\text{Area} = \frac{1}{2} \text{ base} \times \text{height}$$

$$\begin{aligned} A &= \frac{1}{2} bh \\ A &= \frac{1}{2} 15 \times 10 \\ A &= 75 \text{ cm}^2 \end{aligned}$$

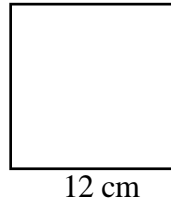

$$\text{Area} = \text{length} \times \text{breadth}$$

$$\begin{aligned} A &= lb \\ A &= 12 \times 12 \\ A &= 144 \text{ cm}^2 \end{aligned}$$

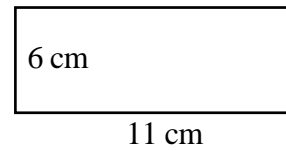

$$\text{Area} = \text{length} \times \text{breadth}$$

$$\begin{aligned} A &= lb \\ A &= 11 \times 6 \\ A &= 66 \text{ cm}^2 \end{aligned}$$

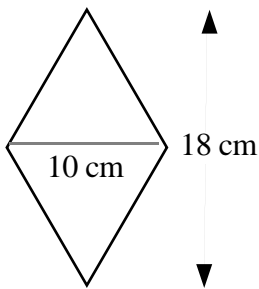

$$\text{Area} = \frac{1}{2} (\text{diagonal 1} \times \text{diagonal 2})$$

$$\begin{aligned} A &= \frac{1}{2} D \times d \\ A &= \frac{1}{2} 10 \times 18 \\ A &= 90 \text{ cm}^2 \end{aligned}$$

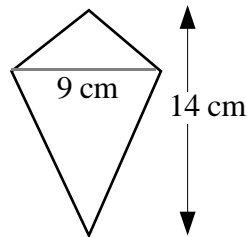

$$\begin{aligned} A &= \frac{1}{2} D \times d \\ A &= \frac{1}{2} 9 \times 14 \\ A &= 63 \text{ cm}^2 \end{aligned}$$

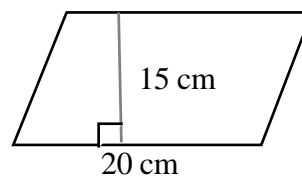

$$\text{Area} = \text{base} \times \text{height}$$

$$\begin{aligned} A &= bh \\ A &= 20 \times 15 \\ A &= 300 \text{ cm}^2 \end{aligned}$$

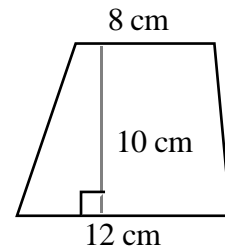

$$\text{Area} = \frac{1}{2} (a + b) \times h$$

$$\begin{aligned} A &= \frac{1}{2} (a+b)h \\ A &= \frac{1}{2} (8+12) \times 10 \\ A &= 100 \text{ cm}^2 \end{aligned}$$

Exercise 1 may now be attempted

Composite Shapes

Students should be encouraged to split shapes up and draw the separate parts

Example 1

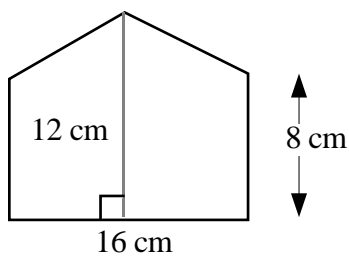



Area =

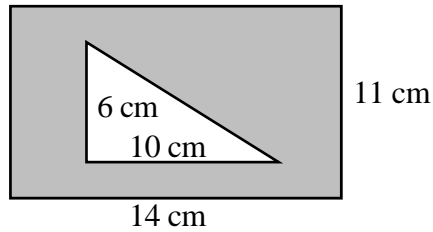

$$\begin{aligned} &= \frac{1}{2} b \times h + l \times b \\ &= \frac{1}{2} 16 \times 12 + 16 \times 8 \\ &= 32 \text{ cm}^2 + 128 \text{ cm}^2 \\ &= 160 \text{ cm}^2 \end{aligned}$$

Example 2



Area =		–	
Area =	$l \times b$	–	$\frac{1}{2} b \times h$
Area =	14×11	–	$\frac{1}{2} 10 \times 6$
Area =	154 cm^2	–	30 cm^2
Area =	124 cm^2		

Exercise 2 may now be attempted

B. Find the Volume of a Cube or Cuboid

Encourage the students to count the number of cubes on the top (or bottom) layer and calculate the volume of cuboids by multiplying this by the number of layers.

Introduce the formula:

$$\text{Volume of cuboid} = \text{length} \times \text{breadth} \times \text{height}$$

$$\text{or } V = l b h$$

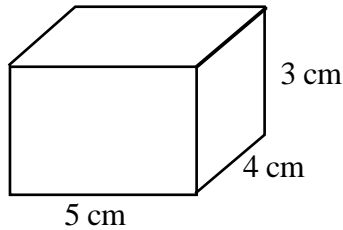

Example $V = l \times b \times h$
 $V = 5 \times 4 \times 3$
 $V = 60 \text{ cm}^3$
 (point out the units)

Exercise 3 may now be attempted

C. Find the Circumference and Area of a Circle

The following notes assume a value of 3.14 for π .

Circumference of a circle

Discuss with the students the need to take care, depending on whether the diameter or radius is given in a question.

Example 1

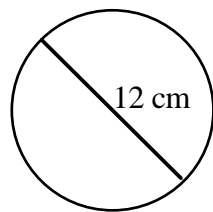

$$C = \pi \times D$$

$$C = 3.14 \times 12$$

$$C = 37.7 \text{ cm (to 3 figure accuracy)}$$

Example 2

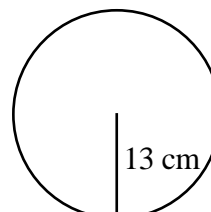

$$C = \pi \times D$$

$$C = 3.14 \times 26 \leftarrow \text{(note)}$$

$$C = 81.6 \text{ cm (3 fig accuracy)}$$

Exercise 4 Q1 to 6 may now be attempted

Go over, on the board, an example of 'part circles' with the students.

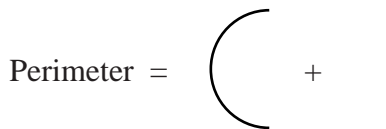
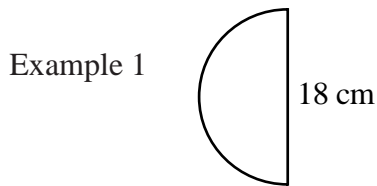

$$P = \pi D \div 2 + 18$$

$$P = 3.14 \times 18 \div 2 + 18$$

$$P = 28.26 + 18$$

$$P = 46.26 \text{ cm}$$

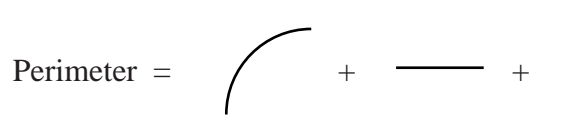
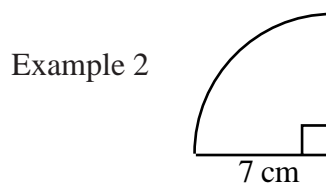

$$P = \pi D \div 4 + 7 + 7$$

$$P = 3.14 \times 14 \div 4 + 7 + 7$$

$$P = 10.99 + 7 + 7$$

$$P = 24.99 \text{ cm}$$

Exercise 4 Q 7 and 8 may now be attempted

Area of a Circle

Go over on the board the two cases with the students – i.e. given a radius or given a diameter.

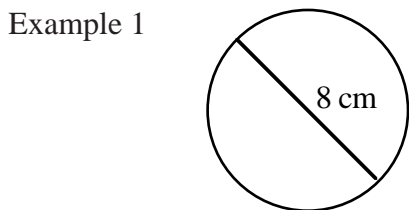

$$A = \pi \times r^2$$

$$A = 3.14 \times 4 \times 4 \text{ ← (note)}$$

$$A = 50.24 \text{ cm}^2$$

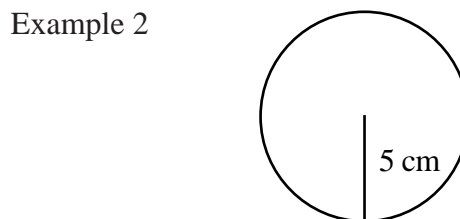

$$A = \pi \times r^2$$

$$A = 3.14 \times 5 \times 5$$

$$A = 78.5 \text{ cm}^2$$

Exercise 5 may now be attempted (questions 1 to 6)

Go over on the board an example of finding the areas of ‘part circles’ with the students.

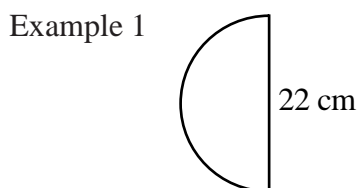

$$\text{Area} = \pi \times r^2 \div 2$$

$$\text{Area} = 3.14 \times 11 \times 11 \div 2$$

$$\text{Area} = 189.97 \text{ cm}^2$$

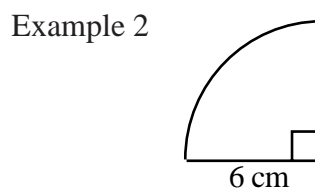

$$\text{Area} = \pi \times r^2 \div 4$$

$$\text{Area} = 3.14 \times 6 \times 6 \div 4$$

$$\text{Area} = 28.26 \text{ cm}^2$$

Exercise 5 Q 7 and 8 may now be attempted, followed by the Check-up for Basic Geometry.

EXPRESSIONS AND FORMULAE

A. Evaluate an Expression

Give the students an explanation of what an 'Expression' is.

Use the following examples to show how to replace letters by numbers in:

$$a + b, a - b, ab, ba, 2a, a^2, 2a^2.$$

Examples: If $a = 5$, $b = 4$, $c = 3$, $d = 1$ and $e = 0$, find the value of:

$a + b$	$b - d$	ac	$3a$	abe
$= 5 + 4$	$= 4 - 1$	$= 5 \times 3$	$= 3 \times 5$	$= 5 \times 4 \times 0$
$= 9$	$= 3$	$= 15$	$= 15$	$= 0$
$2a - 3c$	b^2	$4c^2$	$a^2 - 2d - 23$	
$= 10 - 9$	$= 4^2$	$= 4 \times 3^2$	$= 5^2 - 2 - 23$	
$= 1$	$= 16$	$= 4 \times 9$	$= 25 - 2 - 23$	
		$= 36$	$= 0$	

The use of brackets can be investigated by the students themselves, in Q6.

Exercise 1 may now be attempted

B. Evaluate a Formula Expressed in Words

Give the students an explanation of what a Formula is as opposed to an Expression.

Use the following examples to show what a 'Formulae Expressed in Words' looks like:

'the area of a rectangle equals its length multiplied by its breadth'

'to find the cost of a number of ice cream cones, multiply the number of cones by 20 pence'

Encourage the students to suggest some more.

Show the following example on the board:

Example 1. If a centipede has one hundred legs, how many legs do 20 centipedes have?

Ans: $20 \times 100 = \underline{2000 \text{ legs}}$

Example 2. To cook a piece of roast, give it 25 minutes per pound and then a further 15 minutes. I have a 6 pound roast. How long should I cook it for?

Ans: 6×25 minutes, then add 15 minutes
 $= 150 + 15$ minutes
 $= \underline{165 \text{ minutes}}$

Exercise 2 may now be attempted

C. Evaluate a Formula Expressed in Symbols

Explain the following to the students:

‘Formulae Expressed in Symbols’, ‘Plugging in numbers for letters’.

Explain the ‘ π ’, and ‘ $\sqrt{\quad}$ ’ buttons on the calculator, and that / means divide.

Examples of formulae

$$A = L \times B$$

$$\text{Area} = \text{Length} \times \text{Breadth}$$

$$D = S \times T$$

$$\text{Distance} = \text{Speed} \times \text{Time}$$

Encourage the students to suggest some more formulae.

Do the following on the board:

Example 1. $P = s - b$ Find P , when $s = 6.3$ and $b = 5.1$.

$$\begin{aligned}\text{Ans: } P &= s - b \\ &= 6.3 - 5.1 \\ &= \underline{1.2}\end{aligned}$$

Example 2. $P = 2L + 2B$ Find P , when $L = 16$ and $B = 9$.

$$\begin{aligned}\text{Ans: } P &= 2L + 2B \\ &= 2 \times 16 + 2 \times 9 \\ &= 32 + 18 \\ &= \underline{50}\end{aligned}$$

Example 3. $T = 2\sqrt{L}$ Find T , when $L = 25$.

$$\begin{aligned}\text{Ans: } T &= 2\sqrt{L} \\ &= 2 \times \sqrt{25} \\ &= 2 \times 5 \\ &= \underline{10}\end{aligned}$$

Example 4. $V = \pi r^2 h$ Find V , when $\pi = 3.14$, $r = 10$ and $h = 4$.

$$\begin{aligned}\text{Ans: } V &= \pi r^2 h \\ &= 2 \times 3.14 \times 10^2 \times 4 \text{ (remind students that } 10^2 = 10 \times 10) \\ &= \underline{2512}\end{aligned}$$

Example 5. The equation of a straight line is $y = \frac{1}{2}x + 6$. Find y , when $x = 2$.

$$\begin{aligned}\text{Ans: } y &= \frac{1}{2}x + 6 \\ &= \frac{1}{2} \times 2 + 6 \\ &= 1 + 6 \\ &= \underline{7}\end{aligned}$$

Exercise 3 may now be attempted.

Do the Checkup for Expressions and Formulae.

CALCULATIONS IN EVERYDAY CONTEXTS

A. Carry out Money Calculations in Everyday Contexts

Wage Rise

Discuss with the students why a wage rise is given.

Discuss the terms 'per annum' and 'monthly salary'.

Questions 1 and 2 of Exercise 1 focus on actual (money) pay increases as opposed to percentage increases.

Questions 3 - 7 concentrate on percentage wage increases.

As percentages were dealt with earlier in the unit, students should not require too much reminding of how to work out a percentage of a quantity.

Example 1. Find 5% of £180 Example 2. Find 2.5% of £220

Ans:	5% of £180	2.5% of £220
	$= \frac{5}{100} \times £180$	$= \frac{2.5}{100} \times £220$
	$= £9$ (by calculator)	$= £5.50$ (by calculator)

Note: the % button on a calculator could be used, if preferred.

Example 3. mainly to show setting down.....

Mr. Hedges gets paid £82 per week. He gets a 2% wage increase.
What is his new weekly wage?

Ans:	Increase	$= 2\%$ of £82
		$= \frac{2}{100} \times £82$
		$= £1.64$
	New wage	$= £82 + £1.64 = \underline{£83.64}$

Exercise 1 may now be attempted.

Commission

Give students an explanation of the idea of Commission, and encourage a discussion as to who receives it.

As in Exercise 1, percentages are used predominantly.

Example:

Ailsa is a cosmetic consultant. She gets paid a monthly salary of £850 plus 3% commission on all her cosmetic sales.

What is her monthly pay for a month in which her sales are £4000?

Ans:	Commission	$= 3\%$ of £4000
		$= \frac{3}{100} \times £4000 = £120$
	Total for month	$= £850 + £120 = \underline{£970}$

Note: In Q6, Q7 and Q9 commission is based on sales **over** a certain amount:
e.g. sales are £25 000, but commission is based on all sales over £20 000, so only £5000 can be used in calculations.
It is recommended that students should be allowed to investigate this for themselves.

Q8 does **not** involve 'sales over'. This question is intentionally put there to discover whether or not students can distinguish between the two types of questions.

Exercise 2 may now be attempted.

Overtime and Bonus

Discuss with the students the following:

Overtime, Bonus, Double Time, Time and a Half, Gross Pay.

Example 1.

Maurice works for 40 hours per week, getting paid £5.20 per hour.

When he works overtime he gets paid double time.

What is his pay for a week during which he works 4 hours overtime?

Ans: Normal Time = 40 hours at £5.20
 = £208
 Overtime = $4 \times 2 \times £5.20$
 = £41.60
 Total = £249.60

Example 2.

Molly works part-time in a doctor's surgery - 25 hours per week at a rate of £4.40 an hour.

Her overtime is paid at time and a half.

Calculate her pay for a week when she works 8 hours overtime.

Ans: Normal Time = 25 hours at £4.40
 = £110
 Overtime = $8 \times 1.5 \times £4.40$
 = £52.80
 Total = £162.80

Exercise 3 may now be attempted.

Hire Purchase

Explain the following terms to the students:

Deposit, Instalments (Payments), Total HP, Cash Price.

Questions 1 and 2 use monetary deposits, whereas Questions 3 - 6 use percentage deposits.
Questions 7 and 8 require 'working backwards' to obtain the cost of instalments.

Example 1.

The Cash Price of a video recorder is £210.

It can be paid for by hire purchase - deposit £21 and 9 payments of £22.

Find the difference between the total HP price and the cash price.

Ans: Cash Price = £210
 HP Price deposit £21
 payments $9 \times £22 = £198$
 Total HP = £219
 HP £9 dearer

Example 2.

A nest of tables costs £340 cash or paid up by a deposit of 12% of the cash price and 22 instalments of £15 each.

Calculate how much more expensive it is to pay by HP.

Ans: Cash Price = £340
 HP Price deposit 12% of £340
 = $\frac{12}{100} \times £340$
 = £40.80
 payments $22 \times £15 = £330$
 Total HP = £370.80
 HP £30.80 dearer.

Exercise 4 Questions 1 - 6 may now be attempted.

For Questions 7 and 8:

- either - explain the method for finding the price of instalments, given the total HP price and the deposit.
- or - allow the students to investigate the method by making an attempt at Q7 and Q8, then go over them as required.

Exercise 4 Q7 and Q8 may now be attempted

Insurance Premiums (Life)

The following terms should be explained to the students:

Whole Life Policy, Endowment Policy (with profits), Annual, Premium, and the idea of 'for every £1000 insured'.

Both tables in the exercise should be discussed with the students.

Begin by asking orally for answers to questions like:

What is the rate, per £1000, for a 29 year old male smoker taking out a Whole Life policy?

Ask the students more oral questions for 'per £1000' for both whole life and endowment policies, then move on to asking them about insuring for £2000, £3000 etc.

Follow this up with the following examples on the board:

Example 1.

Matt Thew is 28 and doesn't smoke.

What is his annual premium for a whole life policy for £5000?

$$\begin{aligned}\text{Ans:} \quad \text{Premium for } \pounds 1000 &= \pounds 1.90 \\ \text{Premium for } \pounds 5000 &= \pounds 1.90 \times 5 \\ &= \underline{\pounds 9.50}\end{aligned}$$

Point out to students that not all policies will be for amounts rounded to nearest £1000. Discuss policies for £4500, £5620

Example 2.

Margo Telfer is 33 and smokes.

She takes out a 20 year endowment policy for £2200.

What is her annual premium?

$$\begin{aligned}\text{Ans:} \quad \text{Premium for } \pounds 1000 &= \pounds 5.05 \\ \text{Premium for } \pounds 2200 &= \pounds 1.90 \times 2200 \div 1000 \quad (\text{or } \pounds 1.90 \times 2.2) \\ &= \underline{\pounds 11.11}\end{aligned}$$

Exercise 5 may now be attempted.

Insurance Premiums (House and Contents)

Discuss with the students why we need to insure our house and its contents.

Questions 1 - 4 of the exercise are on House Insurance

Questions 5 - 13 are on Contents Insurance

Example 1. House Insurance

Tommy Tindall lives in a detached villa in Larks. His house is worth £98 000 and is insured with a company who charge him £2.30 'per £1000 value of your house'.

How much is Tommy's annual premium?

$$\begin{aligned}\text{Ans:} \quad \text{Premium for } \pounds 1000 &= \pounds 2.30 \\ \text{Premium for } \pounds 98000 &= \pounds 2.30 \times 98000 \div 1000 \quad (\text{or } \pounds 2.30 \times 98) \\ &= \underline{\pounds 225.40}\end{aligned}$$

Exercise 6 Questions 1 - 4 may now be attempted.

Discuss with the students why 'contents' premiums may vary depending on where you live. Explain why insurance companies have bands like A to F in the table.

Example 2.

Mary McDonald had the contents of her house valued at £8500. She lives in Area B.

How much is Mary's annual premium for her contents?

Ans: Premium for £1000 = £2.50
 Premium for £8500 = £2.50 × 8500 ÷ 1000 (or £2.50 × 8.5)
 = £21.25

Exercise 6 Questions 5 - 13 may now be attempted.

B. Solve Problems involving Exchange Rates

Discuss with the students what Exchange Rates are, why we have them and where they are found (e.g. newspapers, internet, banks, travel agents etc.).

Discuss the table with the students, mentioning each country and what its currency is called.

Questions 1 - 10 From sterling to 'foreign currency'

Questions 11 - 15 From 'foreign currency' to sterling

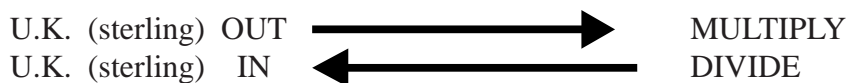

Give students the simple memory aid **Changing from £'s → 'MULTIPLY'**

Example 1.

Example 2.

How many pesetas do you get for £15? How many dollars do you get for £27.50?

Ans: £1 = 248 pesetas
 £15 = 248 × 15
 = 3720 pesetas

Ans: £1 = 1.6 \$
 £27.50 = 1.6 × 27.50
 = 44 \$

Exercise 7 Questions 1 - 10 may now be attempted.

Give students the other memory aid **Changing to £'s → 'DIVIDE'**

Example 2.

Change 130.5 marks to £'s Sterling.

Ans: 2.9 marks = £1
 130.5 marks = 130.5 ÷ 2.9
 = £45

Exercise 7 Questions 11 - 15 may now be attempted.

Then Checkup for Calculations in Everyday Contexts.

MATHEMATICS 1 (INT 1) — STUDENT MATERIALS

CONTENTS

Basic Calculations

A. Find a Percentage of a Quantity	5
B. Express One Quantity as a Percentage of Another	7
C. Rounding	8
D. Direct Proportion	10
Checkup	13

Basic Geometric Properties

A. Areas of Simple Composite Shapes	17
B. Volumes of Cubes and Cuboids	19
C. Circumferences and Areas of Circles	21
Checkup	25

Expressions and Formulae

A. Evaluate an Expression	29
B. Evaluate a Formula Expressed in Words	30
C. Evaluate a Formula Expressed in Symbols	32
Checkup	34

Calculations in Everyday Contexts

A. Carry out Money Calculations in Everyday Contexts	37
B. Solve Problems Involving Exchange Rates	45
Checkup	47

Specimen Assessment Questions	49
--------------------------------------	----

Answers	51
----------------	----

BASIC CALCULATIONS

By the end of this set of exercises, you should be able to

- (a) find a percentage of a quantity
- (b) express one quantity as a percentage of another
- (c) round calculations to a given degree of accuracy
- (d) solve simple problems on direct proportion.

A. Find a Percentage of a Quantity

Exercise 1

- Express the following percentages as decimal fractions:
 - 50%
 - 75%
 - 25%
 - 10%
 - 20%
 - 30%
 - 40%
 - 60%
 - 70%
 - 80%
 - 90%
 - 15%
 - 32%
 - 64%
 - 82%
 - 5%
 - 2%
 - 17.5%
 - 22.5%
 - 8.2%
 - $17\frac{1}{2}\%$
 - $8\frac{1}{2}\%$
 - $12\frac{1}{2}\%$
 - $1\frac{1}{2}\%$
- What is the best way of finding:
 - $33\frac{1}{3}\%$
 - $66\frac{2}{3}\%$of a quantity?
- Calculate:
 - 50% of £20
 - 75% of £40
 - 25% of £200
 - 10% of £68
 - 20% of £45
 - 30% of £160
 - 40% of £180
 - 60% of £8
 - 70% of £9
 - 80% of £9.50
 - 90% of £2000
 - 15% of £3
 - 32% of £18
 - 64% of £18
 - 82% of £5
 - 5% of £2500
 - 2% of £20
 - 17.5% of £400
 - 22.5% of £200
 - 8.2% of £200
 - $17\frac{1}{2}\%$ of £20
 - $8\frac{1}{2}\%$ of £40
 - $12\frac{1}{2}\%$ of £4
 - $1\frac{1}{2}\%$ of £2
- What is:
 - $33\frac{1}{3}\%$ of £90
 - $66\frac{2}{3}\%$ of £120?
- At a meeting, only 18% of the 200 people were female.
How many people were:
 - female
 - male?
- A bottle holds 500 millilitres of diluted juice. 90% of this is water.
How many millilitres of water is this?
- Mavis bought a 750 gram box of chocolates on Saturday afternoon.
By evening only 30% of them were left.
What weight of chocolates was left?
- The village of Biston has 4800 residents. Only 2% of them attended a local meeting.
 - How many villagers attended the meeting?
 - How many did not bother to go?
- A jet was flying at 32 000 feet when one of its engines failed.
The jet dropped by 32% in height.
By how many feet did it drop?

10. When David was 14 he was 140 cm tall. During his 15th year he grew by 18%.
- By how much had he grown?
 - What was his height when he reached 15 years?
11. There are 300 animals on McBain's farm.
43% are cows, 13% are pigs, 22% are sheep and 12% are horses.
- Find the number of:
 - cows
 - pigs
 - sheep
 - horses.
 - If the rest of his animals are goats, find:
 - the percentage of goats
 - the number of goats.
12. At Stanford City Football Club, 90% of its home support are season ticket holders.
The stadium has room for 44 200 home supporters.
- How many are season ticket holders?
 - How many do not have a season ticket?

Exercise 2

- Write down the interest you would receive on £100 for 1 year at the following rates of interest:
 - 5% p.a.
 - 7% p.a.
 - 8% p.a.
 - 12% p.a.
 - 2¹/₂% p.a.
- Calculate the interest would you receive after 1 year at 4% p.a. on:
 - £100
 - £200
 - £500
 - £1000
 - £50.
- Calculate the interest on £95 for 1 year at the following rates:
 - 8% p.a.
 - 10% p.a.
 - 15% p.a.
 - 4% p.a.
 - 1·2% p.a.
- Harold gets 4·5% interest per year on the £550 in his account.
How much interest will he have earned after 1 year and how much does he now have in the bank?
- Calculate the interest on £300 for **6 months** at the following rates:
 - 5% p.a.
 - 12% p.a.
 - 8·5% p.a.
 - 12·5% p.a.
 - 10·2% p.a.
- Calculate the interest on £1500 for **3 months** at the following rates:
 - 5% p.a.
 - 8% p.a.
 - 12·5% p.a.
 - 5·5% p.a.
 - 6·2% p.a.
- Mrs. Nicolson borrows £1200. She must pay back the loan plus interest at a rate of 9% per year.
Calculate the interest she must pay if she manages to pay back the loan in:
 - 1 year
 - 6 months
 - 9 months
 - 4 months
 - 5 months.

Exercise 3

1. An electrical store is offering discounts on TV sets.
Work out: (i) the actual discount (ii) the new price for each item.



2. A toy shop has been told to increase the price of its goods.
Work out: (i) the actual increase (ii) the new price for each item.



3. Work out the 17.5% VAT (Value Added Tax) you need to pay on items which, before VAT, cost:
(a) £10 (b) £28 (c) £4 (d) £102 (e) £1000.
4. A new computer is priced at £1200 + VAT at $17\frac{1}{2}\%$.
(a) What is the cost of the VAT?
(b) What is the price of the computer, including VAT?
5. A gas bill comes to £244 without VAT.
What is the total cost of the gas bill if 8% VAT is added?
6. An electricity bill comes to £302 without VAT.
What is the total cost of the electricity bill after 8% VAT is added?

B. Express One Quantity as a Percentage of Another

Exercise 4

1. Express £10 as a percentage of:
(a) £20 (b) £40 (c) £50 (d) £100 (e) £200.
2. Express the first number as a percentage of the second:
(a) £23 as a percentage of £46 (b) £30 as a percentage of £50
(c) £90 as a percentage of £360 (d) £1.20 as a percentage of £3.00
(e) £540 as a percentage of £900 (f) £8.50 as a percentage of £85
(g) 90p as a percentage of £4.50 (h) 186 cm as a percentage of 620 cm
(i) 560 g as a percentage of 800 g (j) 150 mm as a percentage of 3000 mm.

3. Of the 40 guests at a party, only 8 were men.
What percentage were: (a) men (b) women?
4. Of the 180 cars which took part in a rally, 45 of them were green.
What percentage of them were green?
5. From my weekly pay of £280, I pay £84 in rent.
What percentage of my pay do I pay out on rent?
6. 2000 people were waiting at the airport, due to flight delays.
The first flight to leave was to Shetland. 80 people boarded the plane.
What percentage of the people at the airport was this?
7. For each vacuum cleaner, find:
 - (i) the actual fall in price.
 - (ii) the fall in price expressed as a percentage of the 'old price'.

(a)  **OLD PRICE**
£200
NEW PRICE
£150

(b)  **OLD PRICE**
£140
NEW PRICE
£118

C. Rounding

To the nearest: whole number, ten, hundred, thousand.

Exercise 5

1. Round the following numbers to the nearest whole number:

(a) 4.2	(b) 4.4	(c) 4.6	(d) 7.6	(e) 6.8
(f) 8.4	(g) 2.9	(h) 3.3	(i) 0.8	(j) 4.5
(k) 26.3	(l) 149.1	(m) 648.6	(n) 909.5	(o) 1000.6
2. Write the following times to the nearest minute:

(a) 5.8 minutes	(b) 2.2 minutes	(c) 8.4 minutes	(d) 5.6 minutes	(e) 1.5 minutes
-----------------	-----------------	-----------------	-----------------	-----------------
3. Write the following volumes to the nearest millilitre:

(a) 10.7 ml	(b) 8.2 ml	(c) 27.3 ml	(d) 55.6 ml	(e) 3.5 ml
-------------	------------	-------------	-------------	------------
4. Write the following measurements to the nearest whole unit:

(a) 7.8 cm	(b) 12.3 g	(c) 28.9 km	(d) 22.5 m	(e) 62.2 mm
------------	------------	-------------	------------	-------------
5. Round the following numbers to the nearest ten:

(a) 77	(b) 61	(c) 17	(d) 35	(e) 49
(f) 83	(g) 54	(h) 93	(i) 6	(j) 15
(k) 263	(l) 149	(m) 646	(n) 901	(o) 1007

6. Write the following distances to the nearest 10 km:
 (a) 38 km (b) 51 km (c) 85 km (d) 92 km (e) 99 km
7. Write the following weights to the nearest 10 g:
 (a) 142 g (b) 346 g (c) 509 g (d) 615 g (e) 401 g
8. Write the following measurements to the nearest 10 units:
 (a) 46 mm (b) 11 cm (c) 887 litres (d) 555 g (e) 998 minutes
9. Round the following numbers to the nearest hundred:
 (a) 121 (b) 461 (c) 717 (d) 593 (e) 250
 (f) 888 (g) 274 (h) 94 (i) 8450 (j) 2723
 (k) 5853 (l) 1234 (m) 8080 (n) 2272 (o) 4445
10. Write the following weights to the nearest 100 g:
 (a) 160 g (b) 480 g (c) 220 g (d) 361 g (e) 849 g
11. Write the following distances to the nearest 100 km:
 (a) 354 km (b) 1486 km (c) 1317 km (d) 1099 km (e) 2001 km
12. Write the following measurements to the nearest 100 units:
 (a) 62 days (b) 103 years (c) 2468 litres (d) 8551 g (e) 9998 mm
13. Round the following numbers to the nearest thousand:
 (a) 567 (b) 4293 (c) 7947 (d) 5500 (e) 8359
 (f) 6005 (g) 1001 (h) 32 666 (i) 32 444 (j) 20 551
 (k) 23 500 (l) 23 499 (m) 100 111 (n) 100 500 (o) 6 554 500

Rounding to a given number of decimal places

Exercise 6

1. Round the following numbers to one decimal place:
 (a) 4.29 (b) 4.42 (c) 4.64 (d) 7.67 (e) 6.85
 (f) 8.41 (g) 2.94 (h) 3.33 (i) 0.88 (j) 1.05
 (k) 0.99 (l) 4.96 (m) 48.66 (n) 909.55 (o) 1000.99
2. Round the following numbers to two decimal places:
 (a) 9.127 (b) 2.513 (c) 3.965 (d) 0.394 (e) 12.198
3. Give each sum of money to the nearest penny:
 (a) £2.851 (b) £6.427 (c) £8.049 (d) £9.115 (e) £26.995
4. Round to the nearest hundredth of a second:
 (a) 9.137 s (b) 54.606 s (c) 38.065 s (d) 0.124 s (e) 88.995
5. Round the following numbers to three decimal places:
 (a) 1.1119 (b) 5.3333 (c) 7.3517 (d) 6.2819 (e) 12.9955

6. Round:
- | | | |
|-----------------------------|----------------------------|---------------------------|
| (a) 1.36 to 1 dec. pl. | (b) 14.42 to 1 dec. pl. | (c) 9.239 to 2 dec. pl. |
| (d) 10.501 to 2 dec. pl. | (e) 3.3672 to 3 dec. pl. | (f) 8.6146 to 2 dec. pl. |
| (g) 86.153786 to 3 dec. pl. | (h) 0.186195 to 1 dec. pl. | (i) 15.973 to 1 dec. pl. |
| (j) 0.9983 to 2 dec. pl. | (k) 9.325 to 2 dec. pl. | (l) 19.8205 to 3 dec. pl. |
| (m) 68.95 to 1 dec. pl. | (n) 6.495 to 2 dec. pl. | (o) 8.5758 to 2 dec. pl. |
| (p) 11.7995 to 3 dec. pl. | (q) 1.10851 to 3 dec. pl. | (r) 9.99501 to 2 dec. pl. |

D. Direct Proportion

Exercise 7

- A can of juice costs 32p. What is the cost of 6 cans?
- It costs £4.50 per person to get into the cinema.
What is the cost for a group of 8 people?
- It costs £16 a day to hire a Vauxa Novo car.
How much will it cost me to hire one for my 3 week holiday?
- A car travels 48 miles on a gallon of diesel.
How far will it travel on a full tank of diesel if the tank can hold 12 gallons?
- A hospital porter works for 8 hours per day.
How many hours does he work in 14 days?
- A jeep can travel 330 miles using 15 gallons of fuel.
What is its fuel consumption in miles per gallon?
- 20 senior citizens went on their annual club outing. The total cost for them was £44.
How much did each have to pay?
- A painter finds that a 12 litre drum of emulsion paint covers 462 square metres of ceiling in a large hall. What area will 1 litre of emulsion cover?
- 9 oranges cost £1.62. What is the cost of 5?
- 4 kg of onions cost 72p. What is the cost of 9 kg?
- Mary drives 310 km in 5 hours.
How far will she drive in 2 hours, travelling at the same speed?
- Joanna only gets paid for the hours she works.
On Saturday she got £22.80 for working 6 hours.
How much should she expect to earn the following Saturday when she worked for 4 hours?
- The cost for a 4 mile taxi ride is £3.60. How much should it cost for a 15 mile trip?

14. Daffodil bulbs are sold at 75 for £1·20. How much should 100 daffodils cost?
15. A hotel charges £120 for a 4 day stay. What would the charge be for a fortnight?
16. Helen pays £1·83 for 3 metres of ribbon. How much will she pay for 7 metres?
17. Six text books cost £74·40. What will 25 cost?
18. £18 can be exchanged for 27 dollars. What will I receive for my 6 dollars?
19. Four CDs cost £64. How many will I get for £80?
20. The exchange rate is 2500 Italian Lire to the pound. How much is 51 250 Lire worth?
21. At a bank I can get an exchange rate of 2·15 Swiss Francs to the pound.
 - (a) How many Swiss Francs will I get for £820?
 - (b) How much in British money will I get for 129 Swiss Francs which I brought home from my trip to Switzerland at the same rate of exchange?
22. At senior citizens' tea parties, 7 cakes are provided for every 5 senior citizens. How many cakes will have to be put out if 95 senior citizens are expected?
23. A building 40 metres high casts a shadow 18 metres long. What length of shadow would be cast at the same time by a tree 15 metres high?
24. To insure her house contents for £4100 a woman has to pay £8·20 per month to an insurance company. What will her monthly payments be if she wants to insure it for £5000?
25. It takes a window cleaner 36 hours to clean the windows of an estate with 108 houses. If he works at the same rate, how long will it take him to clean the windows of a similar estate with 216 houses?
26. On a plan, 5 centimetres represents 8 metres.
 - (a) What actual length is represented by 8 centimetres on the plan?
 - (b) What is the length, on the plan, of a wall 36 metres long?
27. David scored 24 out of 60 in his geography test. Calculate what his score is as a percentage.

28. Mrs. Baker is a caterer. A friend asks her for the ingredients for a special cake, but Mrs. Baker gives him the ingredients for five cakes as she is used to catering for lots of people.

Mrs. Baker's recipe for the five cakes is:

1500 g flour	1000 g butter	1000 g sugar
20 eggs	625 ml milk	4500 g raisins

Her friend goes home to make one cake and uses:

300 g flour	200 g butter	200 g sugar
15 eggs	120 ml milk	900 g raisins.

The cake does not taste as good as Mrs. Baker's.

What went wrong?



MATHEMATICS 1 (INTERMEDIATE 1)

Checkup for Basic Calculations

- Find:
(a) 18% of £250 (b) 36% of £4500 (c) 12.5% of £200
- 17% of the 400 members of a youth club were aged 18 or over.
(a) How many of them were 18 or over?
(b) How many of them were under 18?
- A stereo CD player on sale for £65, was reduced by a further 12% in a special offer. What was its new sale price?
- Calculate the interest on £480 for:
(a) 1 year at a rate of 5% per annum (b) 9 months at 2.5% per annum.
- It used to cost £18 to travel by rail to Dundee. The charge was increased by 4% this year. What does it cost to travel to Dundee now?
- At Matko Cash & Carry a canteen of cutlery was on sale at £44 plus 17.5% VAT. The same cutlery was on sale in a High Street store at £51.50 (VAT included). Calculate:
(a) the amount of VAT to be paid on the £44
(b) the total cost of the canteen of cutlery at Matko's
(c) the difference in cost between the shops.
- Duncold library has a stock of 15 000 books. 9000 of them are fiction. What percentage is this?
- Write these measurements to the required degree of accuracy:
(a) 20.6 seconds (to nearest second) (b) 345 metres (to nearest 10 metres)
(c) 3548 litres (to nearest 100 litres) (d) 37489 (to the nearest 1000)
(e) 6.58 (to 1 decimal place) (f) 8.384 (to 2 decimal places)
(g) 2.3358 (to 3 decimal places)
- A racing car mechanic takes 48 seconds to change six tyres. How long will he take to change a set of four tyres?
- A flag pole 4 metres high casts a shadow 2.5 metres long. What length of shadow would be cast at the same time by a 10 metres flag pole?

BASIC GEOMETRIC PROPERTIES

By the end of this set of exercises, you should be able to:

- (a) find the **area** of a simple composite shape
- (b) find the **volume** of a cube or a cuboid
- (c) find the **area** and **circumference** of a circle.

A. Areas of Simple Composite Shapes

Triangles and Quadrilaterals

Exercise 1

1. Find the **areas** of the following triangles:

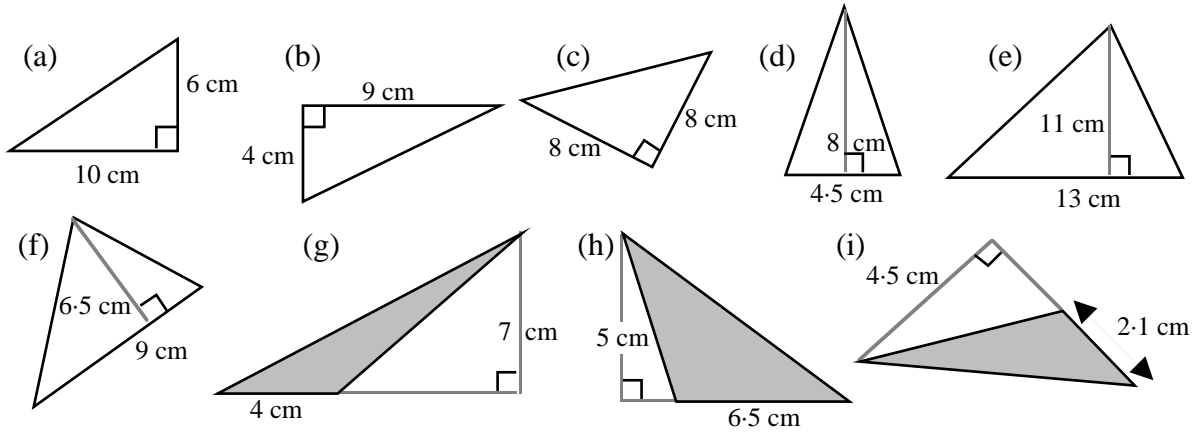

2. Find the **areas** of the following squares and rectangles:

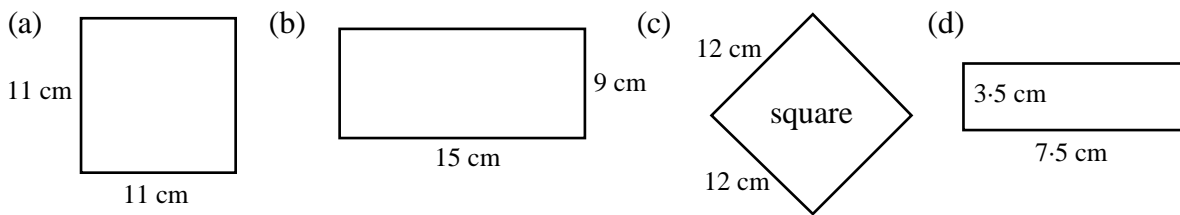

3. Find the **areas** of the following quadrilaterals:

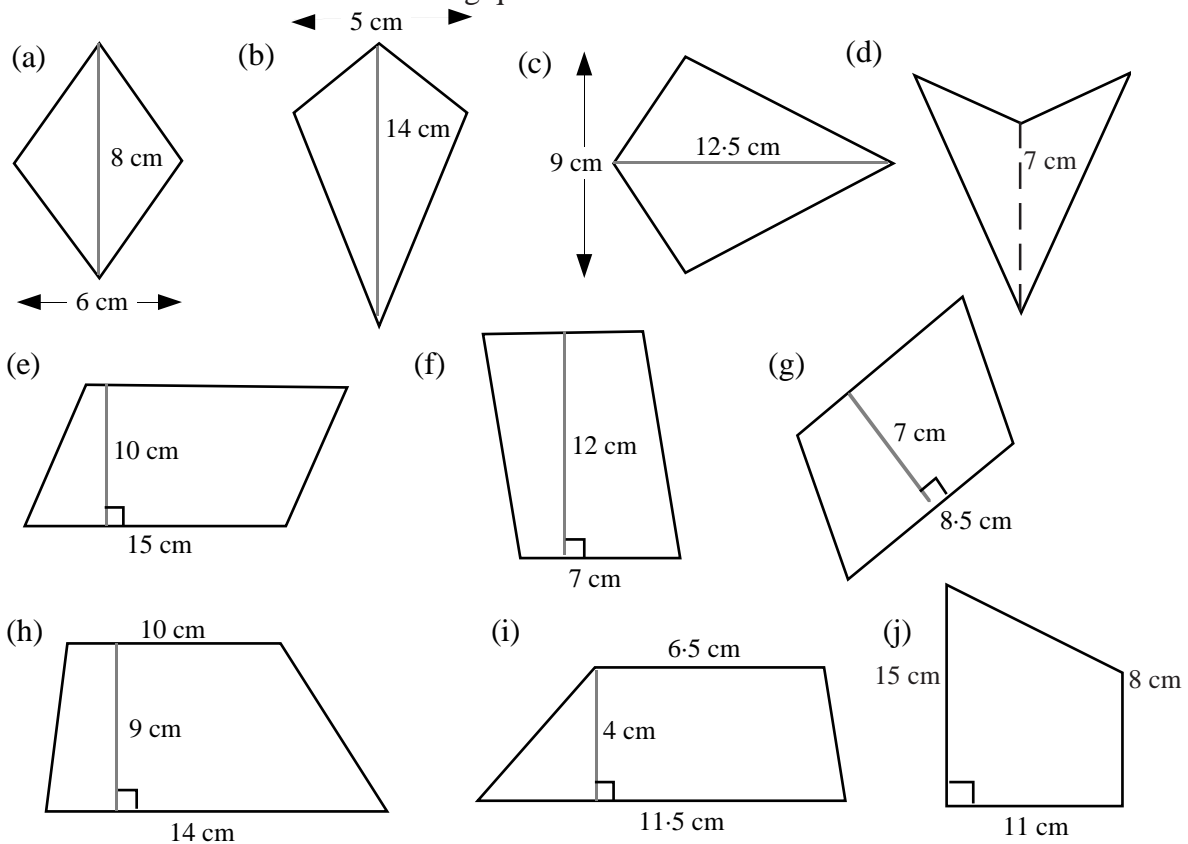

Composite Shapes

Exercise 2

1. For the following composite shapes,
 - (i) split each one into two or three 'parts', showing each part clearly
 - (ii) calculate the area of each part
 - (iii) find the total area of the composite shape.

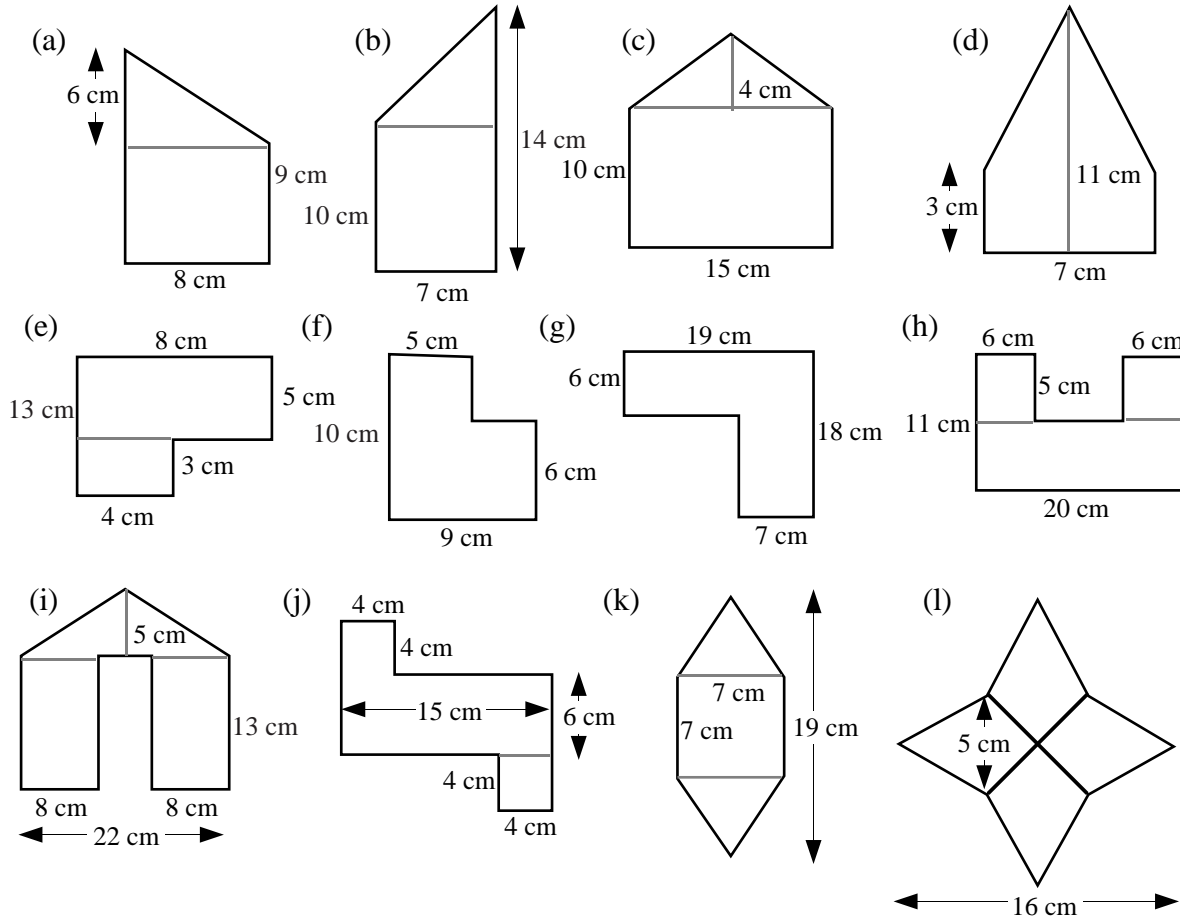

2. For each of the following shapes,
 - (i) find the area of the 'outer' shape
 - (ii) find the area(s) of the hole(s)
 - (iii) find the total shaded area, (the remaining area).

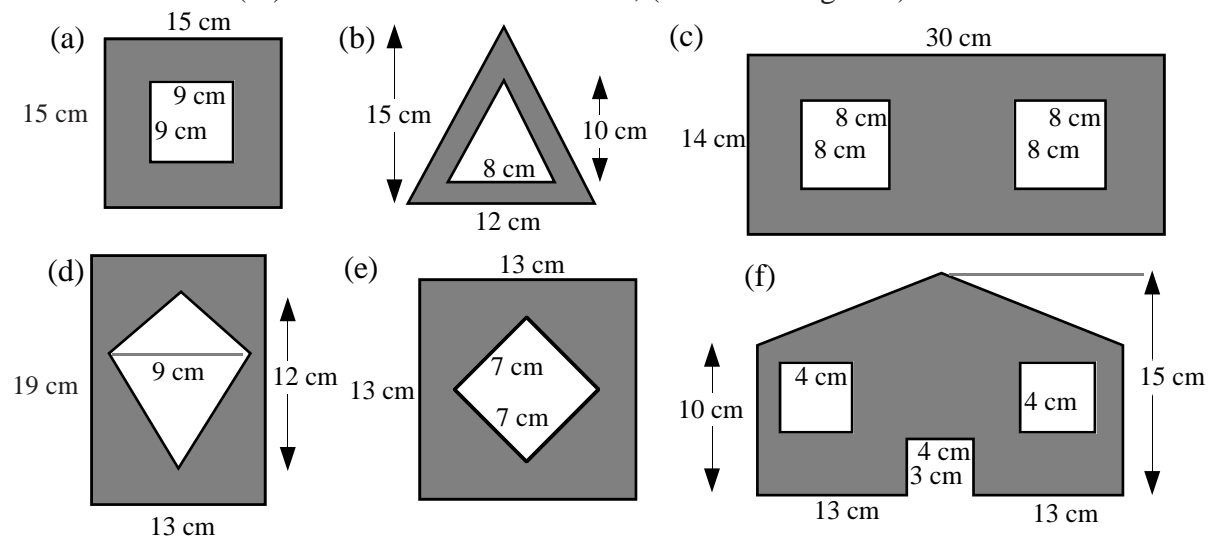

B. Volumes of Cubes and Cuboids

Exercise 3

1. Use a simple counting process to find the **volume** of each of these cubes or cuboids (each box represents 1 centimetre):

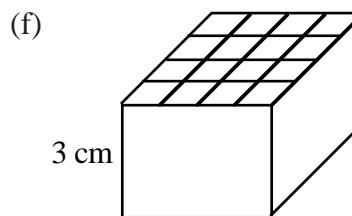
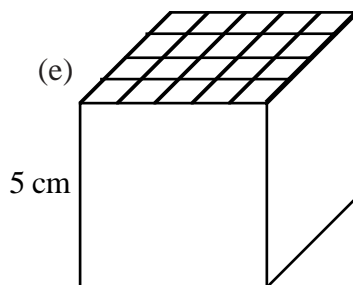
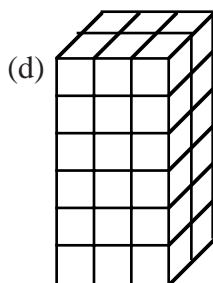
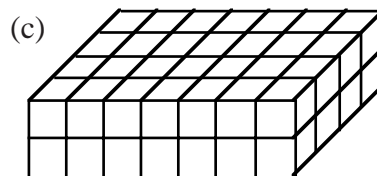
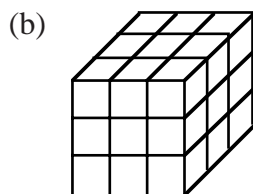
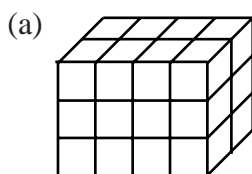

2. Use your formula for the volume of a cuboid to calculate the volumes of these cubes and cuboids.

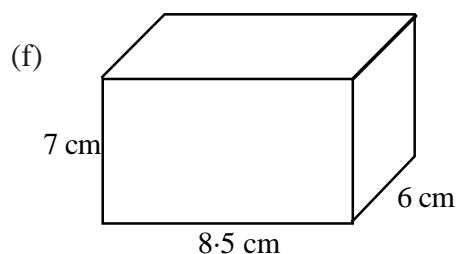
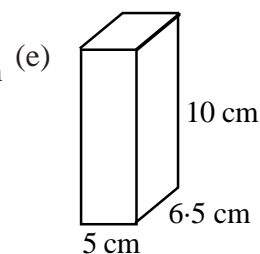
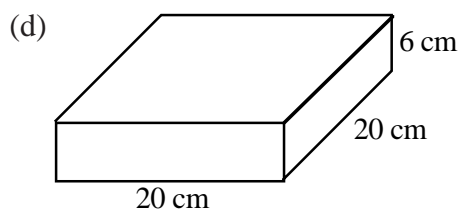
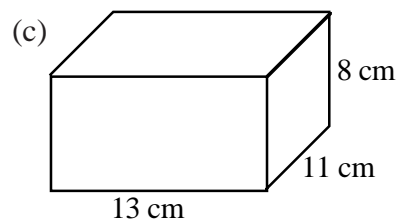
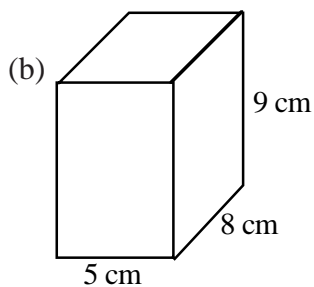
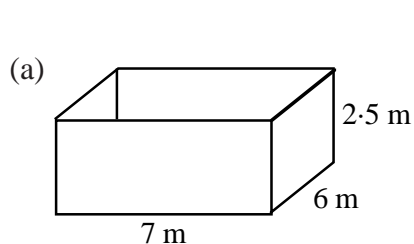

3. (a) The cardboard box, used to pack a microwave, measures 50 centimetres by 40 centimetres and is 45 centimetres high. Calculate the volume of the box (in cm^3).

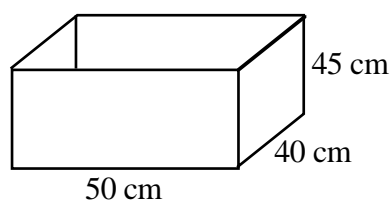

- (b) (i) A rectangular water tank measures 7 metres long, 6 metres wide and 2.5 metres high.

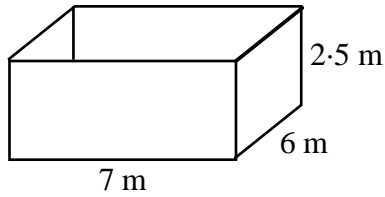

Calculate the volume of water in the tank (in m^3).

- (ii) Given that $1 \text{ m}^3 = 1000$ litres, find how many litres the tank holds.

- (c) A rectangular swimming pool is 25 metres long, 12 metres wide and 1.2 metres deep.

- (i) How many cubic metres does it hold when full?
(ii) Calculate the number of litres it will hold.

4. Calculate the volume of plaster, in cm^3 , needed to make the following mathematical sculptures:

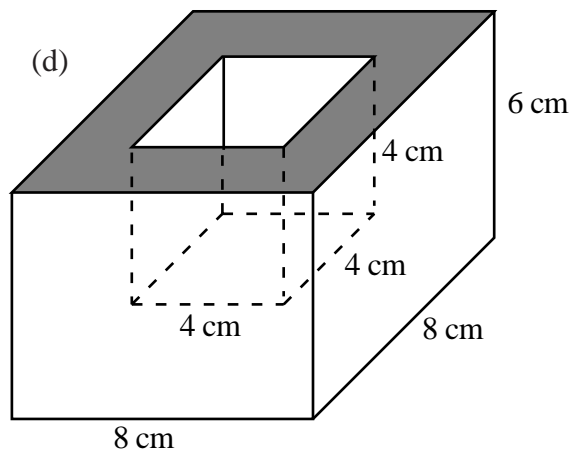
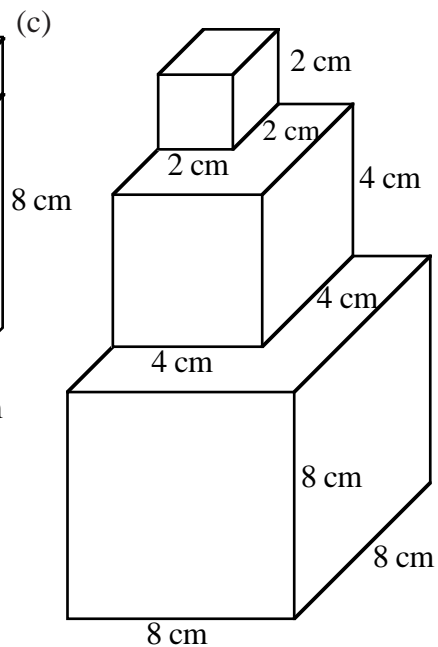
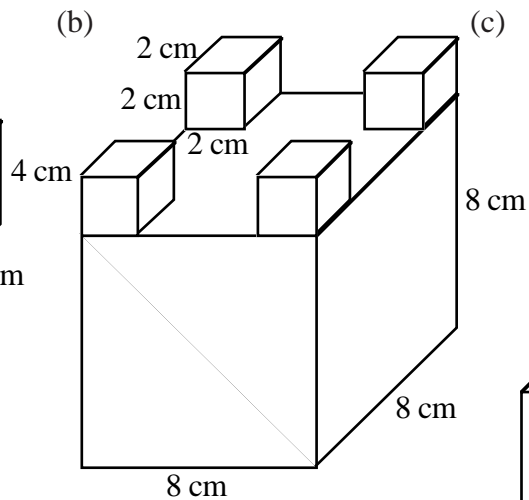
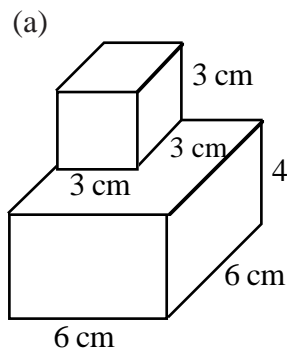

This shape consists of a large cuboid with a smaller cube cut out from it.

Find the volume of the remaining shape.

C. Circumferences and Areas of Circles

Circumference of a Circle ($C = \pi D$)

Exercise 4

1. Calculate the circumferences of the following: (use $\pi = 3.14$)

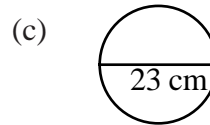
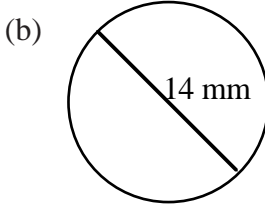
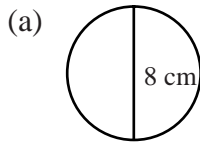

- (d) a circle with diameter 15 centimetres (e) a circle with diameter 22 millimetres
 (f) a circle with diameter 10.5 millimetres (g) a circle with diameter 85 metres.

2. Calculate the circumferences of the following:

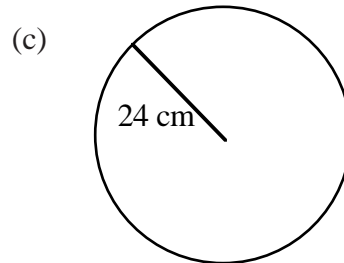
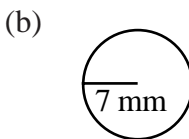
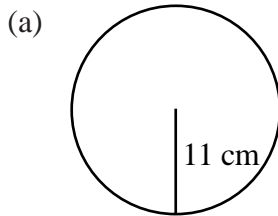

- (d) a circle with radius 6 centimetres (e) a circle with radius 32 millimetres
 (f) a circle with radius 8.5 millimetres (g) a circle with radius 4.3 metres.

3. The diameter of a 10p piece is 24 millimetres. Calculate its circumference.

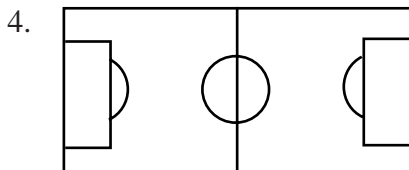

The centre circle of a football pitch has a radius of 3 metres. Calculate the length of the white line forming this circle.

5. A boy flies a model aeroplane around his head attached to a piece of wire 15 metres long. Calculate how far the plane flies on one circuit of its circular path around him when the piece of string is perfectly horizontal.



6. The diameter of a CD is 12 centimetres. Calculate the length of its circumference.

7. (a) Calculate the lengths of the arcs of the following semi-circles:

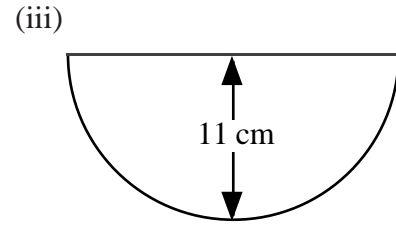
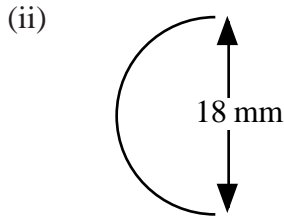
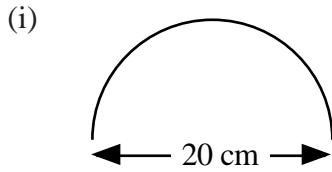

(b) Calculate the lengths of the arcs of the following quarter circles:

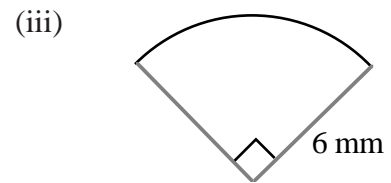
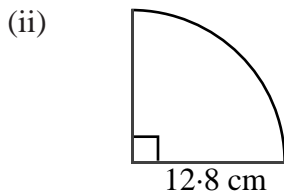
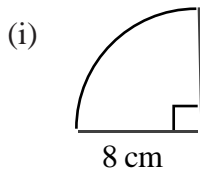

8. For each of the following:

- (i) split each shape up, showing the various lines and curves which form it
- (ii) calculate the length of each part
- (iii) calculate the total perimeter of the shape.

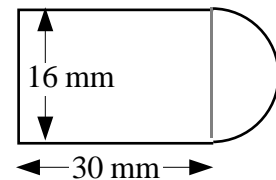
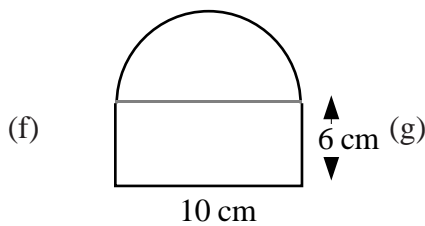
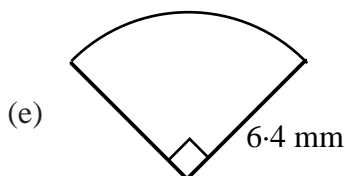
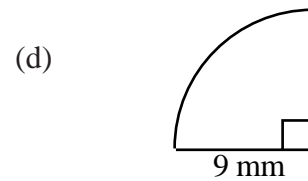
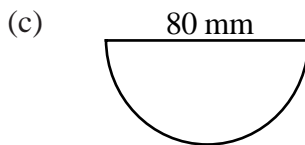
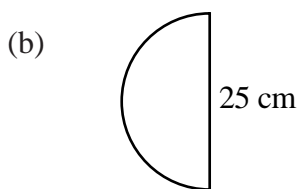
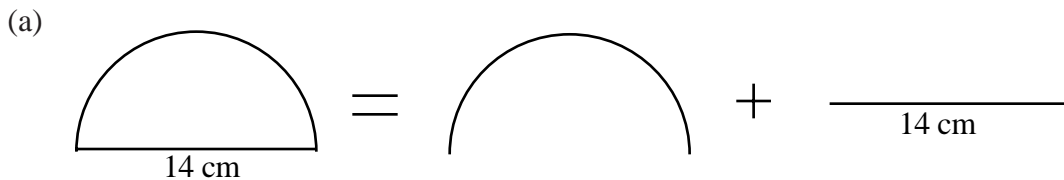

Area of a Circle ($A = \pi r^2$)

Exercise 5

1. Calculate the area of each of the following:

(a)

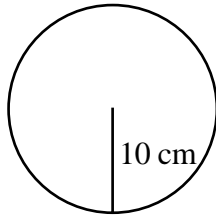

(b)

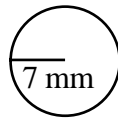

(c)

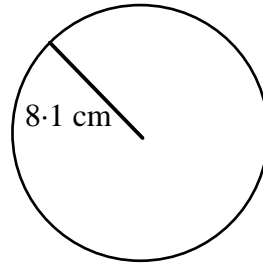

(d) a circle with radius 11 centimetres

(e) a circle with radius 15 metres

(f) a circle with radius 6.5 millimetres

(g) a circle with radius 30 millimetres.

2. Calculate the areas of the following:

(a)

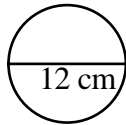

(b)

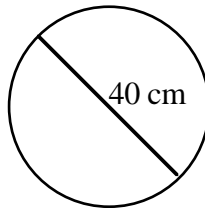

(c)

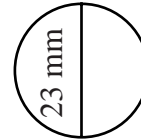

(d) a circle with diameter 16 centimetres

(e) a circle with diameter 3 millimetres

(f) a circle with diameter 24 millimetres

(g) a circle with diameter 4.5 metres.

3. A ten pence piece has diameter 2.4 centimetres. Calculate its area.

4. A roundabout has a diameter of 18 metres. Calculate its area.

5. A circular metal drain cover has a diameter of 350 millimetres. Calculate its area.

6. A circular rug has diameter 1.4 metres. Calculate the area of the rug.

7. Calculate the areas of the following part circles.

(a)

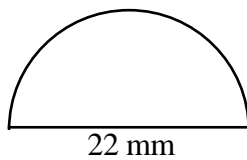

(b)

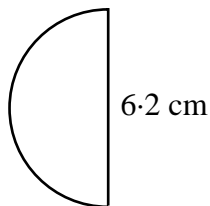

(c)

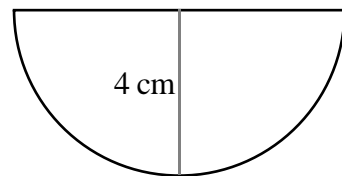

(d)

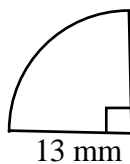

(e)

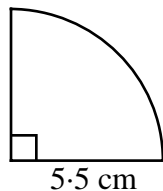

(f)

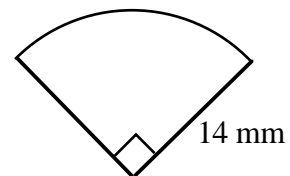

8. Composite Shapes. For each of the following shapes:
- split each one up showing the various parts
 - calculate the area of each part
 - write down the total area of the shape.

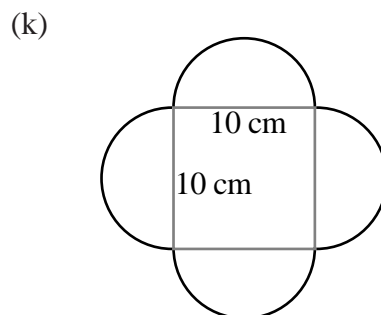
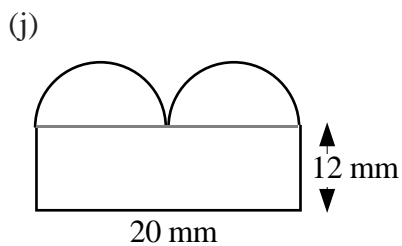
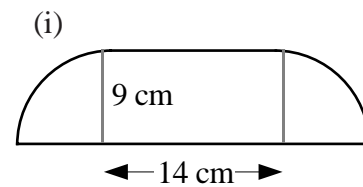
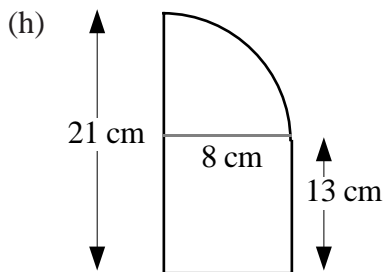
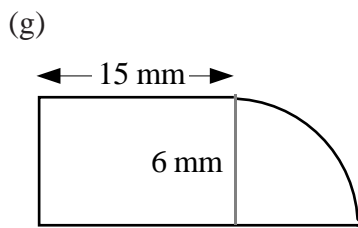
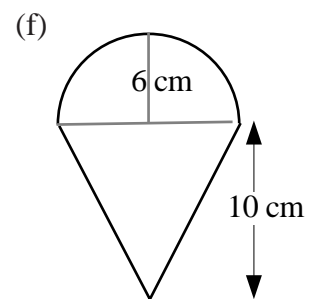
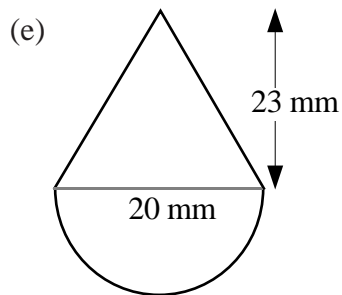
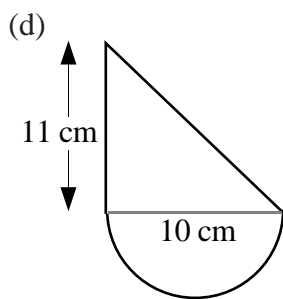
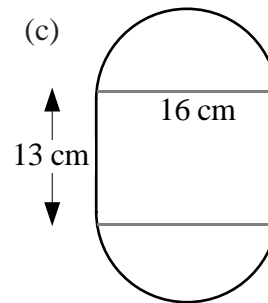
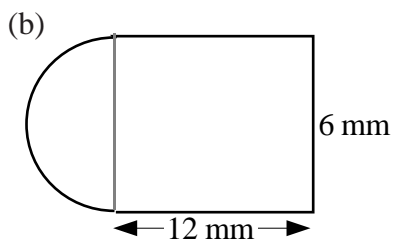
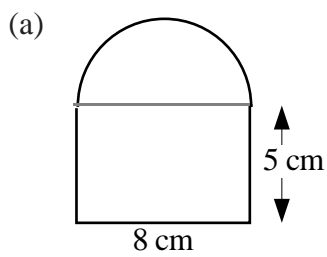

MATHEMATICS 1 (INTERMEDIATE 1)

Checkup for Basic Geometric Properties

1. Find the areas of the following triangles:

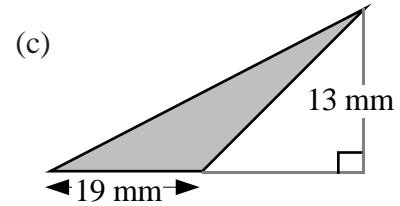
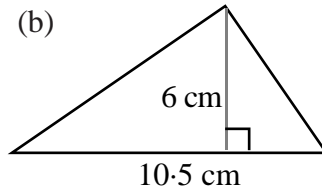
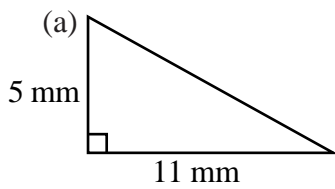

2. Find the areas of the following quadrilaterals:

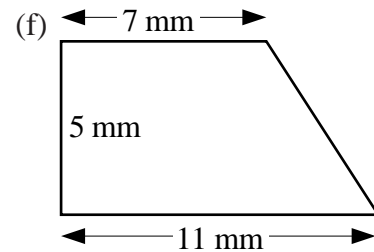
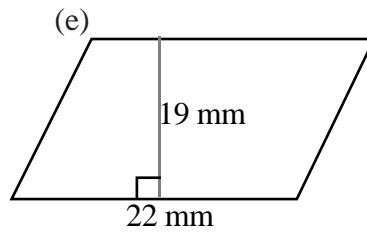
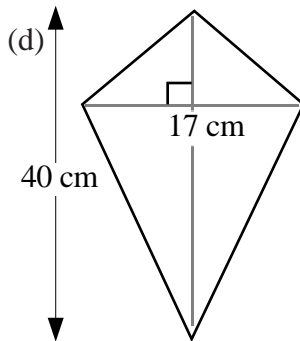
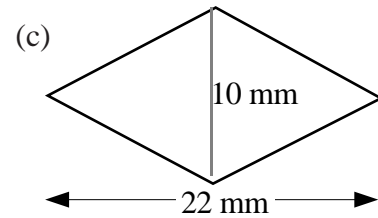
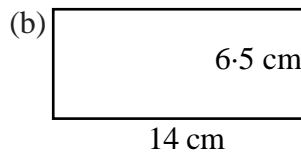
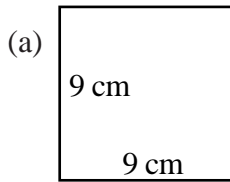

3. Split the following shapes into triangles and rectangles and from this, calculate the areas of each of the shapes.

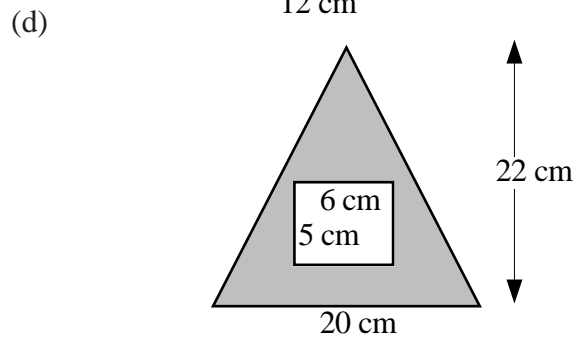
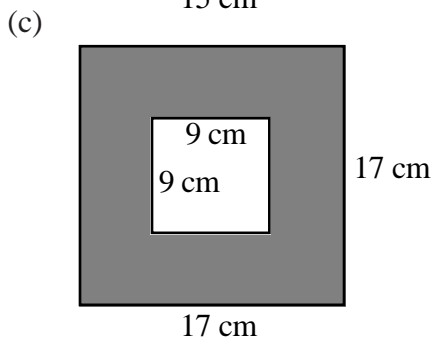
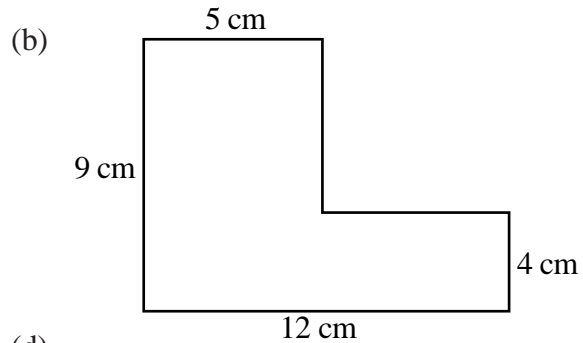
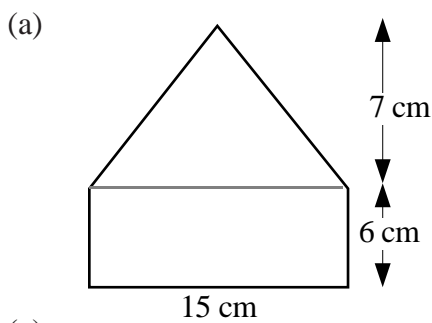

4. Calculate the volumes of the following boxes, (in cm^3).

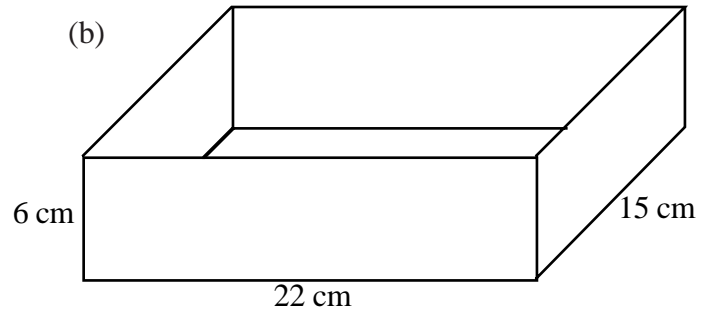
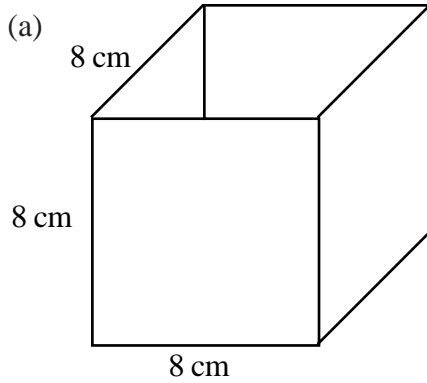

5. How many litres of water will this tray hold?

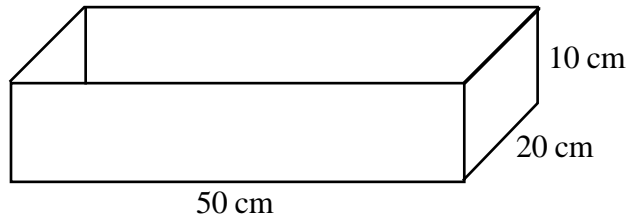

6. Calculate the **circumferences** of the following two circles:

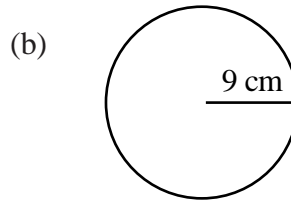
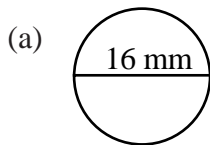

7. A car's tax disc has a diameter of 7.5 centimetres. Calculate its circumference.

8. Calculate the perimeter of the following two shapes:

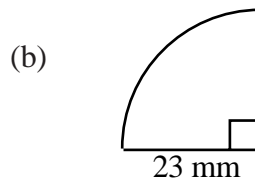
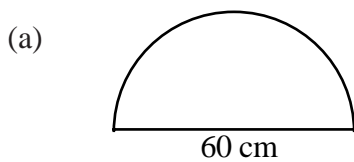

9. Calculate the **areas** of the following two circles:

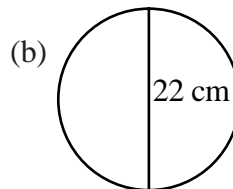
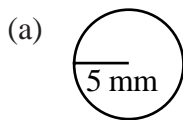

10. A circular badge has a radius of 2.3 centimetres. Calculate its area.

11. Calculate the area of the following three shapes:

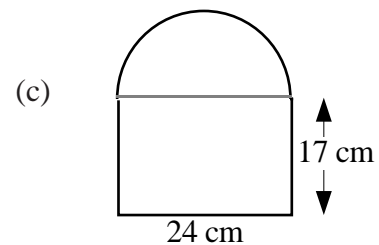
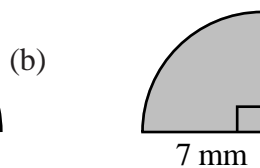
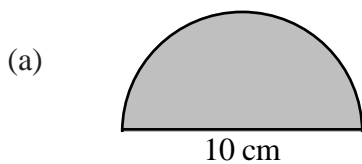

EXPRESSIONS AND FORMULAE

By the end of this set of exercises, you should be able to

- (a) evaluate expressions
- (b) evaluate formulae expressed in words
- (c) evaluate simple formulae expressed in symbols.

A. Evaluate an Expression

Exercise 1

- For $a = 6$ and $b = 5$, work out:

(a) $a + b$	(b) $a - b$	(c) ab	(d) $4a$	(e) $7b$
(f) $3ab$	(g) $10ba$	(h) $a \div 3$	(i) $b \div 5$	
- For $p = 7$ and $q = 15$, work out:

(a) $p + q$	(b) $q - p$	(c) pq	(d) qp	(e) $10p$
(f) $8q$	(g) p^2	(h) q^2	(i) p^2q^2	
- We could represent the cost of 3 watermelons and 4 peaches by $3w + 4p$ where w is the cost of one watermelon and p is the cost of one peach.

What is the cost if:

- | | |
|---------------------------|-----------------------------|
| (a) $w = 2$ and $p = 1$? | (b) $w = 3$ and $p = 2$? |
| (c) $w = 6$ and $p = 6$? | (d) $w = 20$ and $p = 32$? |

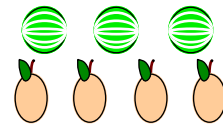

- Hotdogs cost 70 pence, Burgers cost 80 pence and a Milk shake costs 60 pence.
 $\mathbf{H} = 70$, $\mathbf{B} = 80$, $\mathbf{M} = 60$
 - What is the value of $2\mathbf{H} + 3\mathbf{B} + 5\mathbf{M}$?
 - What is the cost of 2 Hotdogs, 3 Burgers and 5 Milk shakes.
 - What do you notice about your two answers?
- For $d = 5$, $e = 1$ and $f = 8$, calculate:

(a) $d + e + f$	(b) $f - d$	(c) $f - e$	(d) $d - e + f$	(e) $f - e + d$
(f) $f + d - e$	(g) de	(h) df	(i) ef	(j) def
(k) $2d$	(l) $6e$	(m) $8f$	(n) $\frac{1}{2}f$	(o) $\frac{1}{5}d$
(p) $2d + e$	(q) $5e + f$	(r) $2f + d$	(s) $2d - 2e$	(t) $2f - 3d$
(u) $6de$	(v) $3def$	(w) $2f - d - e$	(x) $4d - 2f - 4$	(y) d^2
(z) e^2	(A) f^2	(B) $d^2 - e^2$	(C) $2d^2$	
- If $g = 3$, $h = 2$, $i = 1$ and $j = 0$, find the value of:

(a) $\frac{1}{2}g$	(b) $\frac{1}{2}h$	(c) $\frac{1}{2}i$	(d) $\frac{1}{2}j$	(e) g^2
(f) $2g^2$	(g) $(2g)^2$	(h) i^2	(i) ghi	(j) $(ghi)^2$
(k) $g + h + i$	(l) $(g + h + i)^2$	(m) hij	(n) $(hij)^2$	(o) $j + 2$
(p) $(j+2)^2$	(q) $\frac{g+h}{5}$			

B. Evaluate a Formula Expressed in Words

Exercise 2

1. The number of cough sweets is twelve times the number of packets.
How many cough sweets are there in five packets?
2. Mary's cake stands can hold six cream cakes.
To find the number of cake stands she requires, she must divide the number of cream cakes by six.
How many cake stands does she need for:
(a) 54 cream cakes (b) 90 cream cakes (c) 20 cream cakes?
3. Arnold plays nine holes of golf. He gets a **five** at each of the first eight holes, but gets a **three** at the ninth hole.
What is his total score for the nine holes?
4. A shopkeeper calculates her profit by subtracting her cost price from her selling price.
How much profit did she make on a crate of juice which she sold for £36, having bought it for £28.50?
5. 'To find how many legs bees have, you simply multiply by six'.
How many legs in total do 25 bees have?
6. The average speed, in miles per hour, of a car can be found as follows:
'divide the distance travelled by the time taken'.
What was my average speed for a 480 mile journey which took 8 hours?
7. The area of a triangle is found as follows:
'multiply the Base by the Height and halve the answer'.
Find the area of a triangle with base 12 cm and height 5 cm.
8. The cost of hiring a chainsaw from a garden centre is £10, plus an extra £3 for every day hired.
How much will it cost to hire a chain saw for:
(a) 5 days (b) a week (c) a fortnight?
9. To pay for jeans, ordered by catalogue, the following formula is used:
'multiply the number of pairs of jeans by 20, then add on 2.50'.
The answer is then given in pounds.
(a) How much will five pairs of jeans cost?
(b) What do you think the 2.50 is for?
10. To cook a turkey:
'Give it 30 minutes per pound and then a extra 20 minutes'.
For how many minutes should you cook a 10 pound turkey?

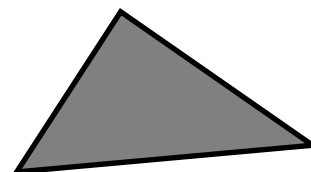

11. To change from degrees Celsius ($^{\circ}\text{C}$) to degrees Fahrenheit ($^{\circ}\text{F}$):
‘Multiply $^{\circ}\text{C}$ by 1.8, and add 32’.
Use this rule to change 30°C to $^{\circ}\text{F}$.

12. If you are given the area of a square, then to find the length of its sides:
‘Find the square root of this area.’
What is the length of the side of a square whose area is 121 cm^2 ?

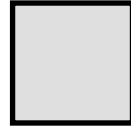

13. The area of a circle can be calculated as follows:
‘Multiply the radius by itself, then
multiply the answer by π on a calculator.’
What is the area of a circle with radius 20 cm?

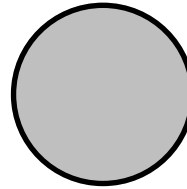

C. Evaluate a Formula Expressed in Symbols

Exercise 3

1. The following formulae are often used in mathematics and science.

For the formulae:

- | | | | |
|-----|---------------------------|------------|---|
| (a) | $P = s - b$ | find P , | when $s = 8.50$ and $b = 5.50$ |
| (b) | $D = S \times T$ | find D , | when $S = 62$ and $T = 4$ |
| (c) | $V = I \times R$ | find V , | when $I = 8$ and $R = 7$ |
| (d) | $V = Ah$ | find V , | when $A = 20.5$ and $h = 10$ |
| (e) | $F = ma$ | find F , | when $m = 12.2$ and $a = 5$ |
| (f) | $Q = m \times s \times t$ | find Q , | when $m = 140$, $s = 1$ and $t = 11$ |
| (g) | $A = 2\pi rh$ | find A , | when $\pi = 3.14$, $r = 100$ and $h = 4$ |
| (h) | $P = 2L + 2B$ | find P , | when $L = 1.2$ and $B = 3.3$ |
| (i) | $T = 20 + 7W$ | find T , | when $W = 9$ |
| (j) | $V = u - 10t$ | find V , | when $u = 70$ and $t = 2.5$ |
| (k) | $D = m/v$ | find D , | when $m = 230$ and $v = 23$ |
| (l) | $R = F/A$ | find R , | when $F = 1250$ and $A = 50$ |
| (m) | $W = mv/10$ | find W , | when $m = 30$ and $v = 6$ |
| (n) | $K = 8M \div 5$ | find K , | when $M = 20$ |
| (o) | $F = \frac{9C}{5} + 32$ | find F , | when $C = 15$ |
| (p) | $x = \sqrt{A}$ | find x , | when $A = 64$ |
| (q) | $T = 2\sqrt{L}$ | find T , | when $L = 16$ |
| (r) | $A = L^2$ | find A , | when $L = 100$ |
| (s) | $D = 5t^2$ | find D , | when $t = 2$ |
| (t) | $P = l^2r$ | find P , | when $l = 3$ and $r = 5$ |
| (u) | $d = (a - b)^2$ | find d , | when $a = 15$ and $b = 10$ |
| (v) | $V = \pi r^2h$ | find V , | when $\pi = 3.14$, $r = 8$ and $h = 100$ |
| (w) | $q = u^2 + 2as$ | find q , | when $u = 3$, $a = 2$ and $s = 1$ |

2. The formula $P = 4L$ is used to find the perimeter of a square with length L . Find P if $L = 5.5$.

3. Given $D = 140$ and $T = 4$, find S from the formula $S = D/T$.

4. The area of a metal plate is given by $A = 1.5 \times a \times b$. Find A when $a = 8$ and $b = 5$.

5. The volume of a cuboid is found by using the formula $V = L \times B \times H$.
Find V when $L = 6$, $B = 4$ and $H = 2.5$.

6. The Perimeter (P) of this shape is found using the formula
$$P = 2a + 2b + c$$

Find P when $a = 4$, $b = 3$ and $c = 5$.

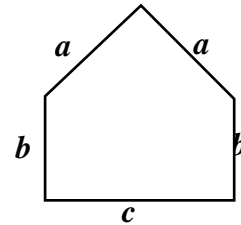

7. The equation of a particular straight line is $y = 4x + 2$.
Find y , when $x = 7$.
8. The equation of another straight line is $y = 1/2x - 3$.
Find y , when $x = 10$.

9. The area of a triangle is found using $A = 1/2 B \times H$.
Find A when $B = 22$ and $H = 10$.

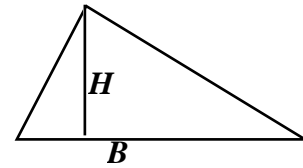

10. The sum of the angles of a polygon with n sides is R right angles, where $R = 2n - 4$.
Find R when $n = 4$.
11. The length of an arc is found by using the formula $L = 1/3(8h - c)$.
Find L when $h = 1$ and $c = 2$.

12.



The illumination I from a lamp is $I = C \div d^2$.
Find I if $C = 20$ and $d = 2$.

13. The volume of a cube is found by using the formulae $V = L^3$, where L is the length of a side of the cube.
Calculate V for $L = 5$.

MATHEMATICS 1 (INTERMEDIATE 1)

Checkup for Expressions and Formulae

- For $x = 3$ and $y = 7$, work out:
(a) $x + y$ (b) $y - x$ (c) xy (d) $8x$ (e) $7y$
(f) $2xy$ (g) $10yx$ (h) $y \div 7$ (i) $x \div 1/2$
- If $a = 4$, $b = 10$, $c = 1$ and $d = 0$, find the value of:
(a) $\frac{1}{2} a$ (b) $\frac{1}{2} b$ (c) $\frac{1}{2} c$ (d) a^2 (e) b^2
(f) $2c^2$ (g) $920d$ (h) abc (i) $b - 2a$ (j) $b - 10c$
(k) $a + b + c$ (l) $(a + b + c)^2$ (m) $\frac{5a + b}{6}$
- There is a simple rule for making a good cup of tea using tea bags:
‘one bag for each person and one for the pot’.
How many tea bags are needed for ten people?
- The net profit made by a cycle shop is given by the formula:
‘profit = (selling price of bike – cost price) \times 0.7’.
Calculate the shop owner’s profit on a twelve speed racing bike bought for £295.99 and sold for £365.99.
- Here is a rough guide as to how to calculate the stopping distance, (D metres), of a car.
Step 1 divide its speed by 30
Step 2 add 1 to the answer
Step 3 multiply this new answer by the speed
Step 4 now divide this by 5
Use this rule to find the stopping distance (in metres) for a car travelling at:
(a) 30 km/hr (b) 75 km/hr (c) 120 km/hr
- The equation of a particular straight line is: $y = 5x + 2$.
Find y , when $x = 4$.
- A library charges a fine (£ F) for any book returned late. To calculate F , use the formula:
$$F = 0.85 + 0.6d$$
 (where d is the number of days late).
Calculate F for: (a) $d = 5$ (b) $d = 10$.
- If $D = m/v$, find D when $m = 108$ and $v = 9$.

CALCULATIONS IN EVERYDAY CONTEXTS

By the end of this set of exercises, you should be able to

- (a) carry out calculations involving money in appropriate social contexts
for example:
 - wage rise; commission; bonus; overtime;
 - hire purchase; insurance premiums

- (b) use exchange rates:
 - to convert from pounds sterling to foreign currency
 - to convert from foreign currency to pounds sterling.

A. Carry out Money Calculations in Everyday Contexts

Wage Rise

Exercise 1

1. Last year, Arthur's works paid an hourly rate of £5.40.
This year he got an increase of £1.10 per hour.
How much will he now earn for a 40 hour shift?
2. A trainee computer operator was offered a starting salary of £5850 per annum.
 - (a) What was her monthly pay?
 - (b) After completing one year, she is to get an increase of £762.
Calculate: (i) her new annual salary (ii) her new monthly pay.
3. Calculate the pay increase after a rise of:
 - (a) 10% is given on a pay of £400 per week.
 - (b) 5% is given on a salary of £3000.
4. Tina is a painter and decorator. Her basic wage is £180 per week.
She is awarded a 5% pay increase.
Calculate:
 - (a) her actual increase
 - (b) her new basic wage.
5. Barbara Hedges gets paid £1230 every fourth week. She receives an 8% pay award, but is told that she will now be paid weekly.
Calculate:
 - (a) her actual increase for the four weeks she works
 - (b) her new weekly wage.
6. Albert is our local paper boy. He did not feel that the £15 per week he was being paid was enough, so he asked for a pay increase of £2 per week!
'I'll do better than that,' said his boss - 'I'll give you a 12% pay increase'.
'Great!' said Albert.
Was Albert correct in celebrating his pay rise?
7. George and his wife Mildred work for the same carpet company and both receive the same salary, £18 120 per annum.
They are called into their boss's office to discuss their annual pay increase.
George is offered a 4% increase and Mildred is offered a pay rise of £700.
Who got the better offer? Explain.

Commission

Exercise 2

1. Calculate the following commissions:
a) 6% of £300 (b) 15% of £250 (c) 1% of £16 050 (d) 2.5% of £620
2. Harold Henning is paid commission of 5% on all power boats he sells.
How much does he get for selling a £26 000 power boat?
3. Tony is a second hand car salesman. He gets paid 4% commission of his sales.
Calculate his commission on sales of:
(a) £200 (b) £600 (c) £950 (d) £1000 (e) £3640
4. Ami, a student, earns extra money by addressing envelopes for a mail order company
in the evenings. For every complete 100 envelopes she addresses she gets 40p.
How much does she earn in an evening when she addresses 4600 envelopes?
5. Jane is a fashion designer. She receives a basic wage of £20 000 per annum
plus 4.5% commission on all her sales. One year her total sales came to £82 000.
How much did she earn in total that year?
6. Tom sells fitted kitchens. He earns a basic monthly wage of £700 and gets 7%
commission on all monthly sales which are over £25 000.
Calculate his wage for a month when his kitchen sales are £48 000. (careful!)
7. Sidney sells double glazing and earns 2.5% commission on all monthly sales over
£2500. Calculate his commission in a month when his sales are worth £12 200.
8. Trevor works for Rainbowear, earning £420 per month plus commission of 8% on
sales. His neighbour, Tina, is a sales representative for Udiddo, earning £510 per
month plus commission of 5% on sales.
In May, they both had sales of £3000.
Calculate their monthly pay for May, saying who earned more and by how much.
9. Mr. Howie is a sales executive. He earns a salary of £54 000 per annum plus 2%
commission on all sales over £260 000.
For a year in which his sales total £400 000, calculate:
(a) his commission for the year
(b) his overall salary for the year.

Overtime and Bonus

Exercise 3

- Sharon is a typist in a lawyer's office. Her basic wage is £8 per hour, but for any overtime she works she gets paid **double time**.
 - What is her overtime hourly rate of pay?
 - One week she worked 6 hours overtime. How much did she get paid for this?
- Gloria works in the mail room for the same firm as Sharon. Her basic wage is £7 per hour and her overtime is at the rate of **time and a half**.
 - What is her overtime hourly rate of pay?
 - One week she worked 8 hours overtime. How much did she get paid for this?
- Jim is a computer operator. He works a basic 40 hour week and is paid £9.20 per hour. Overtime is paid at **double time**. One week Jim worked a total of 52 hours. Find:
 - his basic pay
 - his overtime pay
 - his total pay.
- Donna is a nursery nurse. Her basic rate is £12.50 per hour for a 38 hour week, but at weekends she is paid an overtime rate of double time for looking after the children. Calculate her total pay for a basic week, plus 4 hours overtime on a Saturday and 2 hours overtime on a Sunday.
- Moira's bosses ask her to work 10 hours overtime. She will get paid time and a half. If her usual hourly rate is £10.80, how much will Moira receive for doing the overtime?
- Irene is a joiner's assistant. She works a basic 40 hour week at a rate of £6.50 per hour plus any amount of overtime at time and a half. Calculate her total pay for a week in which she works her normal hours, plus 8 hours overtime.
- A hotel waiter is paid an hourly rate of £4.20 for a basic 36 hour week. Overtime rates are time and a half for weekdays and double time at weekends. Calculate the total wage for a waiter who works a basic week and the following overtime: Tuesday 6 hours, Thursday 4 hours, Saturday 2 hours.
- David Jones works as a golf professional. His golf club pay him £4500 per year and promise him a bonus of £300 each time he finishes in the top ten in a tournament. Calculate his yearly income if he has twelve top ten finishes.
- John Brogan applied for and got this job. Calculate:
 - how many hours per week he will work
 - what his basic pay will be each week
 - how much he will earn in a week in which he gets a £50 bonus.

PART-TIME RECEPTIONIST

1 p.m. – 4.30 p.m. 5 DAYS PER WEEK

£3.80 per hour + BONUS

10. Delia Cook works in a bakery, in charge of making special gateaux. She works a basic 40 hour week for £4 per hour and receives a bonus of £1.80 per gateau for each gateau over the normal 60 she makes in a week.
- What is her basic pay for a week?
 - How much bonus money does she receive if she makes 110 gateaux in a week?
 - What would her total pay be for such a week?

Hire Purchase

Exercise 4

1. All of these items were bought on Hire Purchase.

For each, find:

- the cost of the instalments
- the total HP price
- the difference between the HP price and the cash price.



BIKE £240
or
Deposit £50
and
20 instalments of £10



DISH WASHER £580
or
Deposit £60
and 24 payments of £25



GRAND PIANO £910
or
Deposit £100
and 12 instalments of £75

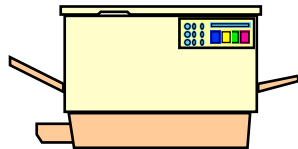

PHOTOCOPIER £3500
or
Deposit £350
and 24 payments of £150

CLOCK £180
or
Deposit £18
and
12 payments of £16

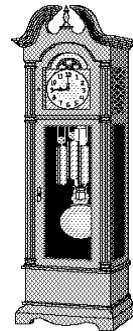

VIDEO CAMERA £432
or
Deposit £40
and 36 payments of £13

TRUCK £5600
or
Deposit £1300
and 48 instalments of £110

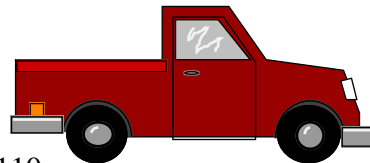

2. A mail order catalogue is advertising a camera showing that it can be bought in 3 ways:

- CASH PRICE £299.99
- 20 WEEKS AT £15.10 PER WEEK
- DEPOSIT £59.99 AND 30 WEEKS AT £8.15

Calculate the difference between the cash price and the cost of each instalment plan.

3. The cash price of a fridge freezer is £620. It can also be bought on hire purchase by paying a deposit of 15% of the cash price and 12 monthly payments of £50.
If paying by HP instead of cash:
- How much is the deposit?
 - What is the total HP price?
 - How much more expensive is it to pay this way?
4. A microwave is on sale at £180. If I want to pay it in instalments, I can make a deposit of 10% of the cash price followed by 20 payments of £10.
How much dearer would it be for me to paying it this way? (show all working)
5. Garden furniture is priced £1250 cash, or hire purchase is possible by putting down a 12% deposit and paying 24 instalments of £50. I decide to splash out and pay cash!
How much did I save by doing this? (show all working)
6. The cash price of a fitted kitchen is £2400.
The hire purchase terms are: 20% deposit plus 36 monthly payments of £66.
Calculate:
- the deposit for HP
 - the total HP price
 - how much dearer is it to pay this way.
7. The hire purchase price of an electric organ is £2250.
I can buy it on Hire Purchase, at no extra cost, as follows:
£250 deposit, with the remaining amount owed spread over 20 equal instalments.
- When the deposit is paid, how much is still owed?
 - How much is each instalment?
8. A CD player, priced at £160 can be bought on hire purchase for the cash price, provided that a 4% deposit is paid and the remainder can be paid over 6 months, by paying six equal monthly instalments.
Calculate:
- the deposit to be paid
 - how much is still owed after the deposit is paid
 - how much is to be paid monthly for the 6 months.

Insurance Premiums (Life)

Exercise 5

Whole Life (with profits)

Age		Non-smoker	Smoker
Male	Female		
16-24	16-31	£1.80	£2.20
25	32	£1.80	£2.25
26	33	£1.85	£2.35
27	34	£1.85	£2.45
28	35	£1.90	£2.60
29	36	£1.95	£2.70
30	37	£2.00	£2.80
31	38	£2.10	£2.90

MONTHLY PREMIUMS FOR EVERY £1000 INSURED

Endowment (with profits)

Age		10 years		20 years	
male	female	Non-smoker	Smoker	Non-smoker	Smoker
16-24	16-31	£8.55	£10.19	£3.48	£5.03
25	32	£8.56	£10.20	£3.50	£5.04
26	33	£8.57	£10.21	£3.51	£5.05
27	34	£8.58	£10.22	£3.52	£5.06
28	35	£8.58	£10.23	£3.54	£5.07
29	36	£8.59	£10.24	£3.55	£5.08
30	37	£8.60	£10.24	£3.56	£5.09
31	38	£8.61	£10.25	£3.57	£5.10

- What are the monthly premiums for these £1000 policies?
 - Whole life for a 34 year-old female, non-smoker.
 - Whole life for a 17 year-old male, smoker.
 - Endowment for a 26 year-old male, non-smoker, over 10 years.
 - Endowment for a 37 year-old female, smoker, over 20 years.
- Donna is 24 and does not smoke. She takes out a whole life policy for £1000.
 - What is her monthly premium?
 - If she had decided to take out a policy for £2000, what would her monthly premium have been?
 - What would it have been for:
 - a £4000 policy
 - a £12 000 policy?
- Dave Clarke is 31 and smokes. If he takes out a whole life policy for £4500, what would his monthly premium be?

4. Jennifer Eccles is 30 and a non-smoker. She wishes to take out a 10 year endowment policy for £1000.
 - (a) What is her monthly premium?
 - (b) What would her premium be for a 10 year endowment policy for:
 - (i) £3000 (ii) £5000 (iii) £10 000 (iv) £15 000?

5. Danny Greer is 30 and a smoker. He wishes to take out a 20 year endowment policy for £1000.
 - (a) What is his monthly premium?
 - (b) What would his premium be for a 20 year endowment policy for:
 - (i) £2000 (ii) £6000 (iii) £10 000 (iv) £18 000?

6. Calculate the monthly premiums for these cases:

(a) Fred McCoist	age 29	Smoker	Life	Insured for £6500
(b) Mary Russet	age 36	Non-smoker	Life	Insured for £2250
(c) Fergus McNeill	age 31	Non-smoker	10 years	Insured for £21 500
(d) Allison Fitzpatrick	age 25	Smoker	20 years	Insured for £102 000

Insurance Premiums (House and Contents)

Exercise 6

1. If Housesafe's annual rate for insuring a house is £2.25 per £1000 value of your house, what would the annual insurance premium be for:
 - (a) a flat worth £20 000
 - (b) a villa worth £65 000
 - (c) a bungalow worth £87 000
 - (d) a mansion worth £205 000?

2. Bill Russell lives in a semi-detached house in Hilltown. His house, worth £75 500, is insured with 'Touch and Go', who charge £3.20 per £1000 value of your house. What is Bill's annual premium for house insurance?

3. Along the road from Bill, lives Harriet Johnston. She has a detached villa, valued at £89 400. She is also insured with 'Touch and Go' whom she joined in 1998 when they charged £3.10 per £1000 value of your house. Unfortunately for Harriet, 'Touch and Go' increased their rate to £3.20 per £1000. If her house is now valued at £92 000, what is the increase in Harriet's annual premium?

4. Frank Clark pays his house insurance to Buntin Homes Ltd. To insure his house for the sum of £75 000 he pays Buntin's an annual premium of £165. What rate must Buntin's be charging Frank per £1000 to insure his house?

House Pride – Insurance for House Contents (Rates)

Area	A	B	C	D	E	F	G
Rate for £1000	£2.00	£2.50	£4.00	£5.00	£6.50	£9.00	£14.00

5. The McDonalds live in Area A and insure their house contents for £12 000. How much is their annual premium?
6. The Petersons live in Area D and insure their house contents for £17 000. How much is their annual premium?
7. The Baillies live in Area E and insure their house contents for £25 000. How much is their annual premium?
8. The Wilsons live in Area F and insure their house contents for £33 000. How much is their annual premium?
9. The McKennas live in Area G and insure their house contents for £95 000. How much is their annual premium?
10. The O’Briens live in Area C and insure their house contents for £6250. How much is their annual premium?
11. The Davidsons value their house contents at £45 000. They move from a flat in Area F to a villa in Area A. By how much does their annual premium for house contents fall?
12. The Windsors and the Johnstons both insure their house contents for the sum of £38 000. If the Windsors live in Area C and the Johnstons live in Area E, what is the difference in their annual premiums?

13.

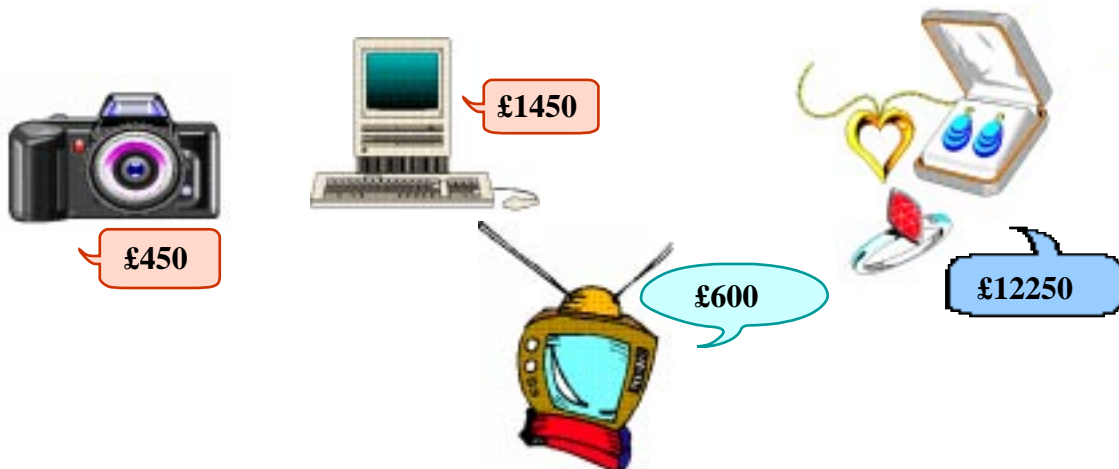

The Buzzard family live in Area D.

- (a) Calculate their total annual premium for insuring the camera, computer, T.V. and jewellery.
- (b) If they decide to pay the premium monthly, how much (to the nearest penny) will their monthly payments be?

B. Solve Problems Involving Exchange Rates

Exercise 7

Rates of Exchange (for £1 Sterling)

Spain	<i>248 pesetas</i>	USA	<i>1.6 dollars</i>	Germany	<i>2.9 marks</i>
Italy	<i>2900 lire</i>	France	<i>9.8 francs</i>	Cyprus	<i>0.85 pounds</i>
Denmark	<i>11.25 kroner</i>	Ireland	<i>1.2 punts</i>	Portugal	<i>297 escudos</i>

1. I have £100. Change this into the currency of each of the countries in the table.
2. Mary and Ian have booked a camping holiday in France. Mary has exchanged £720 and Ian has exchanged £680 to francs. How many francs did each receive?
3. Fred and Flora are on holiday in Florida. One day, they change £125 into dollars to visit a famous theme park. How many dollars do they get?
4. Harry and Jean are going to Legoland in Denmark on a self-catering holiday for a month. They have heard that dining out can be expensive there, so they take £1500 worth of kroner. How many kroner is that?
5. The Beckams are in Dortmund in Germany for a football match. As they are only staying overnight they take £310 with them to change into marks. How many marks will they get?
6. The Strangs are touring Italy. Daughter Nicola reckons that a miniature Leaning Tower of Pisa is worth about £7.50. How many lire does she expect to pay for on ?
7. A beautiful place to spend a holiday week-end is Dublin, where prices for bed and breakfast in a city centre hotel start at £22 per person. What will that be in Irish punts?
8. The Geddes family are sun worshippers, so last year decided to visit Spain and Portugal. They exchanged £750 into pesetas and £610 into escudos. How many pesetas and escudos did they get in for their money?

Rates of Exchange (for £1 Sterling)

Spain	<i>248 pesetas</i>	USA	<i>1.6 dollars</i>	Germany	<i>2.9 marks</i>
Italy	<i>2900 lire</i>	France	<i>9.8 francs</i>	Cyprus	<i>0.85 pounds</i>
Denmark	<i>11.25 kroner</i>	Ireland	<i>1.2 punts</i>	Portugal	<i>297 escudos</i>

9. How many Cypriot pounds will I get for:
 (a) £40 (b) £75 (c) £340 (d) £825 (e) £2200?

10. The Herbistons took £1200 worth of travellers cheques to Spain and found that they were to be charged 2% commission on them.
 (a) How many pesetas did they receive for £1200?
 (b) How many pesetas were they charged for commission?
 (c) How much were they left with after the commission was paid?

11. In France, Mary bought a Euro-Disney T shirt for 196 francs.
 How much would that have been in £'s?

12. In Denmark, Harry bought a cola for 36 kroner!
 Convert this into £'s to see why Harry was shocked.

13. Gareth Strang, in Italy with his family, decides to buy a bottle of Italian perfume for his girlfriend back home. In one shop he was asked to pay 65 250 lire for a small bottle of good quality perfume. To Gareth, it sounded far, far, too expensive....65 250!!
 Really, it was quite a reasonable price.
 How much was it in pounds (£'s)?

14. The Ireland v Scotland rugby match was taking place in Dublin when the Joyces visited the island.
 Mr. Joyce had bought 4 stand tickets for the match, at a total cost of 192 punts.
 Calculate:
 (a) the cost of the four tickets in £'s.
 (b) the cost of each ticket in £'s.

15. The Arthur family consists of Mr. & Mrs. Arthur, Alice and Brian.
 Last year Mr. & Mrs. Arthur went on holiday to Cyprus, Alice went to Portugal and Brian went to Germany.
 On their return, they compared how much money each had brought home from holiday.
 The parents had 34 Cyprus pounds, Alice had 12 177 escudos and Brian had 113.1 marks.
 Who returned with the least amount of money?

MATHEMATICS 1 (INTERMEDIATE 1)

Checkup for Calculations in Everyday Contexts

1. Mr. Gibson, the architect, receives an annual salary of £24 450 and gets paid each month. This year, he is to get an increase of 6%.

Calculate:

- (a) his actual increase
- (b) his new salary
- (c) his new monthly pay.



2. Zoe sells upholstery. She earns a basic monthly wage of £850 and gets 5% commission on all monthly sales over £2500.

Calculate her wage for a month when her upholstery sales are £6000.

3. A hotel receptionist/telephonist is paid an hourly rate of £5.40 for a basic 40 hour week. Overtime rates are time and a half for weekdays and double time at weekends. Calculate the total wage for a receptionist/telephonist who works a basic week and the following overtime:

Monday 2 hours, Tuesday 2¹/₂ hours, Thursday 1¹/₂ hours, Saturday 5 hours.

4. The Bryce family booked up to go on a luxury cruise. The cash price of the holiday was £12 200, but they paid it up by putting down a 10% deposit and paying 10 instalments of £1125.

Calculate:

- (a) the deposit paid
- (b) the cost of the 10 instalments
- (c) the total cost of the holiday
- (d) how much dearer the holiday was by paying it up.

5. Jim Thomson lives in a bungalow in Ovan. His house, worth £95 500, is insured with Ovaninsure, who charge £2.90 per £1000 value of the house.

What is Jim's annual premium for house insurance?

6. Colin Turner and his wife go on a month's vacation to a hotel in Thailand. They change £2250 into bahts, at an exchange rate of 62 bahts to the £.

- (a) Calculate how many bahts they received.
- (b) While they are on holiday they spend 138 951 bahts.
How many have they left?
- (c) On returning home with the remaining bahts, they find that the exchange rate has dropped to 61 bahts to the £.
How many £'s have they got left?

MATHEMATICS 1 INTERMEDIATE 1

Specimen Assessment Questions

- In January 1999, Melburn Rovers F.C. announced that the price of their shares had increased by 3.5%.
If the original price per share was £2, calculate:
 - the increase
 - the new share price.
- A fully laden lorry, weighing 3.5 tonnes arrived at the dumping ground to empty its load. On this journey, the lorry had been carrying 0.825 tonnes of rubbish.
Find the weight of the empty lorry, giving your answer correct to 1 decimal place.
- A transparency 5 cm long and 4 cm broad is projected on to a screen.
If the picture on the screen is 2 m long, what is its breadth?

4. Find the areas of the following three shapes:

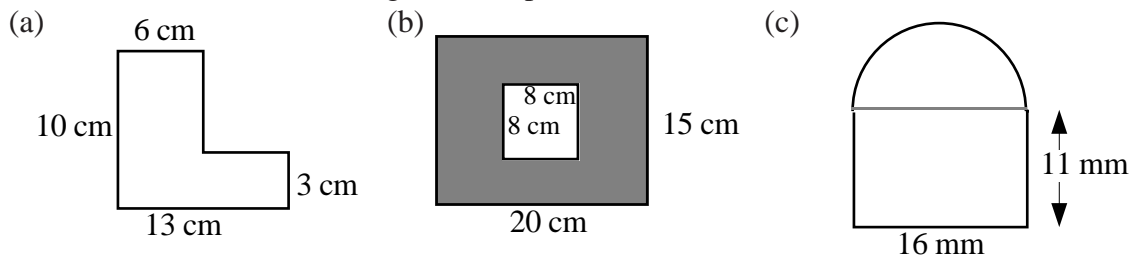

5. Find the volumes of these two solids:

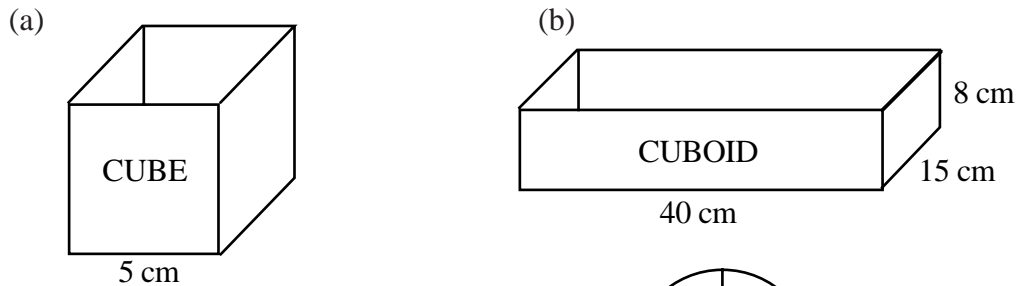

6. (a) Find the circumference of this circle:

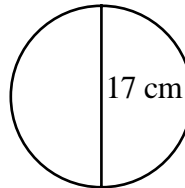

- (b) Find the area of this circle:

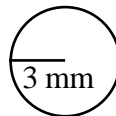

7. For $a = 30$ and $b = 15$, work out:

- | | | | | |
|-------------|--------------|---------------|-----------|----------------|
| (a) $a + b$ | (b) $a - b$ | (c) ab | (d) $4b$ | (e) $b \div 5$ |
| (f) $2ab$ | (g) $2a - b$ | (h) $3a - 6b$ | (i) a^2 | |

8. The travel time (in hours) for a journey is found by dividing the distance travelled (in kilometres) by the average speed of the vehicle.
Calculate how long (in hours), it takes a lorry travelling at 45 km/hr to cover 112.5 km.
(Try now to give your answer in hours and minutes).
9. The perimeter of a rectangular room is found by using the formula $P = 2L + 2B$, where P is the perimeter, L is the length and B is the breadth of the room, in metres.
Use the formula to find the perimeter of such a room with length 6.5 m and breadth 4 m.
10. The Simpson family buy a rally car on Hire Purchase. They put down their old car, worth £6000, as a deposit and pay 36 monthly instalments of £590.
If the cash price of the rally car was £25500, how much dearer was it for them to pay by Hire Purchase?
11. Davina Smith lives in a house in area 5.

Area	1	2	3	4	5	6	7
Rate for £1000	£3.00	£3.50	£5.00	£6.00	£7.50	£9.00	£16.00

She wants to insure the contents of her house for £9500.
What will her annual premium be?

12.

Rates of Exchange (for £1 Sterling)

Spain	<i>248 pesetas</i>	USA	<i>1.6 dollars</i>	Germany	<i>2.9 marks</i>
Italy	<i>2900 lire</i>	France	<i>9.8 francs</i>	Cyprus	<i>0.85 pounds</i>
Denmark	<i>11.25 kroner</i>	Ireland	<i>1.2 punts</i>	Portugal	<i>297 escudos</i>

The Irvine twins, Freddie and Freda, book up their holidays. Freddie is going to Dieppe, in France. Freda is to tour Germany.
Bill Irvine, their father, gives them £500 each for spending money!
How many francs and how many marks, will Freddie and Freda have with them to spend?

ANSWERS FOR MATHEMATICS 1 INT 1.

Basic Calculations

Exercise 1.

- (a) 0.5 (b) 0.75 (c) 0.25 (d) 0.1 (e) 0.2
(f) 0.3 (g) 0.4 (h) 0.6 (i) 0.7 (j) 0.8
(k) 0.9 (l) 0.15 (m) 0.32 (n) 0.64 (o) 0.82
(p) 0.05 (q) 0.02 (r) 0.175 (s) 0.225 (t) 0.082
(u) 0.175 (v) 0.085 (w) 0.125 (x) 0.015
- (a) $\frac{1}{3}$ (b) $\frac{2}{3}$
- (a) £10 (b) £30 (c) £50 (d) £6.80 (e) £9
(f) £48 (g) £72 (h) £4.80 (i) £6.30 (j) £7.60
(k) £1800 (l) £0.45 (m) £5.76 (n) £11.52 (o) £4.10
(p) £125 (q) £0.40 (r) £70 (s) £45 (t) £16.40
(u) £3.50 (v) £3.40 (w) £0.50 (x) £0.03
- (a) £30 (b) £80
- (i) 36 (ii) 164
- 450
- 225 g
- (a) 96 (b) 4704
- 10 240 ft
- (a) 25.2 cm (b) 165.2 cm
- (a) 129 cows 39 pigs 66 sheep 36 horses (b) 10% 30 goats
- (a) 39780 (b) 4420

Exercise 2.

- (a) £5 (b) £7 (c) £8 (d) £12 (e) £2.50
- (a) £4 (b) £8 (c) £20 (d) £40 (e) £2
- (a) £7.60 (b) £9.50 (c) £14.25 (d) £3.80 (e) £1.14
- £24.75 £574.75
- (a) £7.50 (b) £18 (c) £12.75 (d) £18.75 (e) £15.30
- (a) £18.75 (b) £30 (c) £46.88 (d) £20.63 (e) £23.25
- (a) £108 (b) £54 (c) £81 (d) £36 (e) £45

Exercise 3.

- (a) £84 off and pays £336 (b) £36 off and pays £204
- (a) Van up £0.52 to £5.72 (b) Soldier up £0.23 to £4.83 (c) Engine up £1.80 to £24.30
- (a) £1.75 (b) £4.90 (c) £0.70 (d) £17.85 (e) £175
- (a) £210 (b) £1410
- £263.52 6. £326.16

Exercise 4.

- (a) 50% (b) 25% (c) 20% (d) 10% (e) 5%
- (a) 50% (b) 60% (c) 25% (d) 40% (e) 60%
(f) 10% (g) 20% (h) 30% (i) 70% (j) 5%
- (a) 20% (b) 80%
- 25% 5. 30% 6. 4%
- (a) down £50, 25% (b) down £22, 15.7%

Exercise 5.

- (a) 4 (b) 4 (c) 5 (d) 8 (e) 7
(f) 8 (g) 3 (h) 3 (i) 1 (j) 5
(k) 26 (l) 149 (m) 649 (n) 910 (o) 1001
- (a) 6 minutes (b) 2 minutes (c) 8 minutes (d) 6 minutes (e) 2 minutes
- (a) 11 ml (b) 8 ml (c) 27 ml (d) 56 ml (e) 4 ml
- (a) 8 cm (b) 12 g (c) 29 km (d) 23 m (e) 62 mm
- (a) 80 (b) 60 (c) 20 (d) 40 (e) 50
(f) 80 (g) 50 (h) 90 (i) 10 (j) 20
(k) 260 (l) 150 (m) 650 (n) 900 (o) 1010
- (a) 40 km (b) 50 km (c) 90 km (d) 90 km (e) 100 km
- (a) 140 g (b) 350 g (c) 510 g (d) 620 g (e) 400 g
- (a) 50 mm (b) 10 cm (c) 890 litres (d) 560 g (e) 1000 minutes
- (a) 100 (b) 500 (c) 700 (d) 600 (e) 300
(f) 900 (g) 300 (h) 100 (i) 8500 (j) 2700
(k) 5900 (l) 1200 (m) 8100 (n) 2300 (o) 4400
- (a) 200 g (b) 500 g (c) 200 g (d) 400 g (e) 800 g
- (a) 400 km (b) 1500 km (c) 1300 km (d) 1100 km (e) 2000 km
- (a) 100 days (b) 100 years (c) 2500 litres (d) 8600 g (e) 10 000 mm
- (a) 1000 (b) 4000 (c) 8000 (d) 6000 (e) 8000
(f) 6000 (g) 1000 (h) 33 000 (i) 32 000 (j) 21 000
(k) 24 000 (l) 23 000 (m) 100 000 (n) 101 000 (o) 6 555 000

Exercise 6.

- (a) 4.3 (b) 4.4 (c) 4.6 (d) 7.7 (e) 6.9
(f) 8.4 (g) 2.9 (h) 3.3 (i) 0.9 (j) 1.1
(k) 1.0 (l) 5.0 (m) 48.7 (n) 909.6 (o) 1001.0
- (a) 9.13 (b) 2.51 (c) 3.97 (d) 0.39 (e) 12.20
- (a) £2.85 (b) £6.43 (c) £8.05 (d) £9.12 (e) £27.00
- (a) 9.14 s (b) 54.61 s (c) 38.07 s (d) 0.12 s (e) 89.00 s
- (a) 1.112 (b) 5.333 (c) 7.352 (d) 6.282 (e) 12.996
- (a) 1.4 (b) 14.4 (c) 9.24 (d) 10.50 (e) 3.367
(f) 8.61 (g) 86.154 (h) 0.2 (i) 16.0 (j) 1.00
(k) 9.33 (l) 19.821 (m) 69.0 (n) 6.50 (o) 8.58
(p) 11.800 (q) 1.109 (r) 10.00

Exercise 7.

- | | | | | |
|----------------|---|---------------|--------------|--------------|
| 1. £1.92 | 2. £36 | 3. £336 | 4. 576 miles | 5. 112 hours |
| 6. 22 mpg | 7. £2.20 | 8. 38.5 sq. m | 9. 90p | 10. £1.62 |
| 11. 124 km | 12. £15.20 | 13. £13.50 | 14. £1.60 | 15. £420 |
| 16. £4.27 | 17. £310 | 18. £4 | 19. 5 | 20. £20.50 |
| 21 (a) 1763 | (b) £60 | | | |
| 22. 133 | 23. 6.75 m | 24. £10 | 25. 72 hours | |
| 26. (a) 12.8 m | (b) 22.5 cm | | | |
| 27. 40% | 28. He should have used 4 eggs and 125 ml milk! | | | |

Checkup

- | | | | | |
|--------------|------------|-----------------|------------|---------|
| 1. (a) £45 | (b) £1620 | (c) £25 | | |
| 2. (a) 68 | (b) 332 | | | |
| 3. £57.20 | | | | |
| 4. (a) £24 | (b) £9 | | | |
| 5. £18.72 | | | | |
| 6. (a) £7.70 | (b) £51.70 | (c) 20p | | |
| 7. 60% | | | | |
| 8. (a) 21 s | (b) 350 m | (c) 3500 litres | (d) 37 000 | (e) 6.6 |
| (f) 8.38 | (g) 2.336 | | | |
| 9. 32 s | | | | |
| 10. 6.25 m | | | | |

Basic Geometric Properties

Exercise 1.

- | | | | | |
|---------------------------|-------------------------|--------------------------|--------------------------|--------------------------|
| 1. (a) 30 cm^2 | (b) 18 cm^2 | (c) 32 cm^2 | (d) 18 cm^2 | (e) 71.5 cm^2 |
| (f) 29.25 cm^2 | (g) 14 cm^2 | (h) 16.25 cm^2 | (i) 4.725 cm^2 | |
| 2. (a) 121 cm^2 | (b) 135 cm^2 | (c) 144 cm^2 | (d) 26.25 cm^2 | |
| 3. (a) 24 cm^2 | (b) 35 cm^2 | (c) 56.25 cm^2 | (d) 28 cm^2 | (e) 150 cm^2 |
| (f) 84 cm^2 | (g) 59.5 cm^2 | (h) 108 cm^2 | (i) 36 cm^2 | (j) 126.5 cm^2 |

Exercise 2.

- | | | | |
|---------------------------|------------------------|------------------------|------------------------|
| 1. (a) 96 cm^2 | (b) 84 cm^2 | (c) 180 cm^2 | (d) 49 cm^2 |
| (e) 52 cm^2 | (f) 74 cm^2 | (g) 198 cm^2 | (h) 180 cm^2 |
| (i) 263 cm^2 | (j) 122 cm^2 | (k) 91 cm^2 | (l) 80 cm^2 |
| 2. (a) 144 cm^2 | (b) 50 cm^2 | (c) 292 cm^2 | |
| (d) 193 cm^2 | (e) 120 cm^2 | (f) 331 cm^2 | |

Exercise 3.

- (a) 24 cm^3 (b) 27 cm^3 (c) 56 cm^3
(d) 36 cm^3 (e) 100 cm^3 (f) 48 cm^3
- (a) 168 cm^3 (b) 360 cm^3 (c) 1144 cm^2
(d) 2400 cm^3 (e) 325 cm^3 (f) 357 cm^3
- (a) $90\,000 \text{ cm}^3$ (b) (i) 105 m^3 (ii) $105\,000 \text{ litres}$
(c) (i) 360 m^3 (ii) $360\,000 \text{ litres}$
- (a) 171 cm^3 (b) 544 cm^3 (c) 584 cm^3 (d) 320 cm^3

Exercise 4.

- (a) 25.12 cm (b) 43.96 mm (c) 72.22 cm (d) 47.1 cm
(e) 69.08 mm (f) 32.97 mm (g) 266.9 m
- (a) 69.08 cm (b) 43.96 mm (c) 150.72 cm (d) 37.68 cm
(e) 200.96 mm (f) 53.38 mm (g) 27.004 m
- 73.36 mm 4. 18.84 m 5. 94.2 m 6. 37.68 cm
- (a) (i) 31.4 cm (ii) 28.26 mm (iii) 34.54 cm
(b) (i) 12.56 cm (ii) 20.096 cm (iii) 9.42 mm
- (a) 35.98 cm (b) 64.25 cm (c) 205.6 mm (d) 32.13 mm
(e) 22.848 cm (f) 37.7 cm (g) 101.12 mm

Exercise 5.

- (a) 314 cm^2 (b) 153.86 mm^2 (c) 206.0154 cm^2 (d) 379.94 cm^2
(e) 706.5 m^2 (f) 132.665 mm^2 (g) 2826 cm^2
- (a) 113.04 cm^2 (b) 1256 cm^2 (c) 415.265 mm^2 (d) 200.96 cm^2
(e) 7.065 mm^2 (f) 452.16 mm^2 (g) 15.89625 m^2
- 4.5216 cm^2 4. 254.34 m^2 5. $96\,162.5 \text{ mm}^2$ 6. 1.5386 m^2
- (a) 189.97 mm^2 (b) 15.0877 cm^2 (c) 25.12 cm^2
(d) 132.655 mm^2 (e) 23.74625 cm^2 (f) 153.86 mm^2
- (a) 65.12 cm^2 (b) 86.13 mm^2 (c) 408.96 cm^2 (d) 94.25 cm^2
(e) 387 mm^2 (f) 116.52 cm^2 (g) 118.26 mm^2 (h) 154.24 cm^2
(i) 253.17 cm^2 (j) 318.5 mm^2 (k) 257 cm^2

Checkup

- (a) 27.5 mm^2 (b) 31.5 cm^2 (c) 123.5 mm^2
- (a) 81 cm^2 (b) 91 cm^2 (c) 110 mm^2
(d) 340 cm^2 (e) 418 cm^2 (f) 45 mm^2
- (a) 142.5 cm^2 (b) 73 cm^2 (c) 208 cm^2 (d) 190 cm^2
- (a) 512 cm^3 (b) 1980 cm^3
- 10 litres 6. (a) 50.24 mm (b) 56.52 cm
- 23.55 cm 8. (a) 154.2 cm (b) 82.11 mm
- (a) 78.5 mm^2 (b) 379.94 cm^2 10. 16.6106 cm^2
- (a) 39.25 cm^2 (b) 38.465 mm^2 (c) 634.08 cm^2

Expressions and Formulae

Exercise 1

- (a) 11 (b) 1 (c) 30 (d) 24 (e) 35
(f) 90 (g) 300 (h) 2 (i) 1
- (a) 22 (b) 8 (c) 105 (d) 105 (e) 70
(f) 120 (g) 49 (h) 225 (i) 11 025
- (a) 10 (b) 17 (c) 42 (d) 188
- (a) 680 (b) 680 pence (c) They are the same.
- (a) 14 (b) 3 (c) 7 (d) 12 (e) 12
(f) 12 (g) 5 (h) 40 (i) 8 (j) 40
(k) 10 (l) 6 (m) 64 (n) 4 (o) 1
(p) 11 (q) 13 (r) 21 (s) 8 (t) 1
(u) 30 (v) 120 (w) 10 (x) 0 (y) 25
(z) 1 (A) 64 (B) 24 (C) 50
- (a) $1\frac{1}{2}$ (b) 1 (c) $\frac{1}{2}$ (d) 0 (e) 9
(f) 18 (g) 36 (h) 1 (i) 6 (j) 36
(k) 6 (l) 36 (m) 0 (n) 0 (o) 2
(p) 4 (q) 1

Exercise 2.

- 60 2. (a) 9 (b) 15 (c) 4
- 43 4. $\text{£}7.50$ 5. 150 6. 60 m.p.h. 7. 30 cm^2
- (a) $\text{£}25$ (b) $\text{£}31$ (c) $\text{£}52$
- (a) 102.50 (b) postage 10. 320 minutes
- 86°F 12. 11(cm) 13. $1256 - 1257 \text{ cm}^2$ (approx)

Exercise 3.

- | | | | | |
|----------|------------|------------|---------|--------|
| 1. (a) 3 | (b) 248 | (c) 56 | (d) 205 | (e) 61 |
| (f) 1540 | (g) 2512 | (h) 9 | (i) 83 | (j) 45 |
| (k) 10 | (l) 25 | (m) 18 | (n) 32 | (o) 59 |
| (p) 8 | (q) 8 | (r) 10 000 | (s) 20 | (t) 45 |
| (u) 25 | (v) 20 096 | (w) 13 | | |
2. 22 3. 35 4. 60 5. 60 6. 19
7. 30 8. 2 9. 110 10. 4 11. 2
12. 5 13. 125

Checkup

- | | | | | |
|-----------|---------|-------------|--------|--------|
| 1. (a) 10 | (b) 4 | (c) 21 | (d) 24 | (e) 49 |
| (f) 42 | (g) 210 | (h) 1 (i) 6 | | |
2. (a) 2 (b) 5 (c) $\frac{1}{2}$ (d) 16 (e) 100
- (f) 2 (g) 0 (h) 40 (i) 2 (j) 0
- (k) 15 (l) 225 (m) 5
3. 11 4. £49 5. (a) 12 m (b) 52.5 m (c) 120 m
6. 22 7. (a) 3.85 (b) 6.85 8. 12

Calculations in Everyday Contexts

Exercise 1

1. £260
2. (a) £487.50 (b) (i) £6612 (ii) £551
3. (a) £40 (b) £150
4. (a) £9 (b) £189
5. (a) £98.40 (b) £332.10
6. No! Albert only got £1.80, not £2.
7. George by £24.80

Exercise 2

- | | | | | |
|------------|------------|-------------|------------|--|
| 1. (a) £18 | (b) £37.50 | (c) £160.50 | (d) £15.50 | |
|------------|------------|-------------|------------|--|
2. £1300
- | | | | | |
|-----------|---------|---------|---------|-------------|
| 3. (a) £8 | (b) £24 | (c) £38 | (d) £40 | (e) £145.60 |
|-----------|---------|---------|---------|-------------|
4. £18.40 5. £23 690 6. £2310 7. £242.50
8. Trevor £660 Tina £660 Same!
9. (a) £2800 (b) £56800

Exercise 3

1. (a) £16 (b) £96
2. (a) £10.50 (b) £84
3. (a) £368 (b) £220.80 (c) £588.80
4. £625 5. £162 6. £338 7. £231
8. £8100
9. (a) $17\frac{1}{2}$ (b) £66.50 (c) £116.50
10. (a) £160 (b) £90 (c) £250

Exercise 4

1. Bike (a) £200 (b) £250 (c) £10
Dish Washer (a) £600 (b) £660 (c) £80
Piano (a) £900 (b) £1000 (c) £90
V Camera (a) £468 (b) £508 (c) £76
Copier (a) £3600 (b) £3950 (c) £450
Clock (a) £192 (b) £210 (c) £30
Truck (a) £5280 (b) £6580 (c) £980
2. £299.99 £302 £304.49 Differences....£2.01 and £4.50
3. (a) £93 (b) £693 (c) £73
4. £38 5. £100
6. (a) £480 (b) £2856 (c) £456
7. (a) £2000 (b) £100
8. (a) £6.40 (b) £153.60 (c) £25.60

Exercise 5

1. (a) £1.85 (b) £2.20 (c) £8.57 (d) £5.09
2. (a) £1.80 (b) £3.60 (c) £7.20 £21.60
3. £13.05
4. (a) £8.55 (b) (i) £25.65 (ii) £42.75 (iii) £85.50 (iv) £128.25
5. (a) £5.09 (b) (i) £10.18 (ii) £30.54 (iii) £50.90 (iv) £91.62
6. (a) £17.55 (b) £4.39 (c) £185.12 (d) £513.06

Exercise 6

1. (a) £45 (b) £146.25 (c) £195.75 (d) £461.25
2. £241.60 3. £17.26 4. £2.20 5. £24
6. £85 7. £162.50 8. £297 9. £1330
10. £25 11. £315 12. £95 13. (a) £73.75 (b) £6.15

Exercise 7

1. 24 800 pesetas 290 000 lire 1125 kroner 160 \$ 980 francs
 120 punts 290 marks 85 pounds 29 700 escudos
2. 7056 and 6664 3. 200 4. 16 875 5. 899
6. 21 750 7. 26·40 8. 186 000 pesetas 181 170 escudos
9. (a) 34 (b) 63·75 (c) 289 (d) 701·25 (e) 1870
10. (a) 297 600 (b) 5952 (c) 291 648
11. £20 12. £3·20 for a cola!! 13. £22·50
14. (a) £160 (b) £40 15. Brian £39

Checkup

1. (a) £1467 (b) £25917 (c) £2159·75
2. £1025 3. £318·60
4. (a) £1220 (b) £11 250 (c) £12 470 (d) £270
5. £276·95
6. (a) 139 500 bahts (b) 549 bahts (c) £9

Specimen Assessment Questions

1. (a) 7p (b) £2·07 2. 2·7 tonnes 3. 1·6 metres
4. (a) 81 cm² (b) 236 cm² (c) 276·48 mm²
5. (a) 125 cm³ (b) 4800 cm³ 6. (a) 53·38 cm (b) 28·26 mm²
7. (a) 45 (b) 15 (c) 450 (d) 60 (e) 3
 (f) 900 (g) 45 (h) 0 (i) 900
8. 2 hours 30 minutes 9. 21 metres 10. £1740 11. £71·25
12. Freddie 4900 francs Freda 1450 marks